

UPLAY TODAY™

P L A Y S Y S T E M S

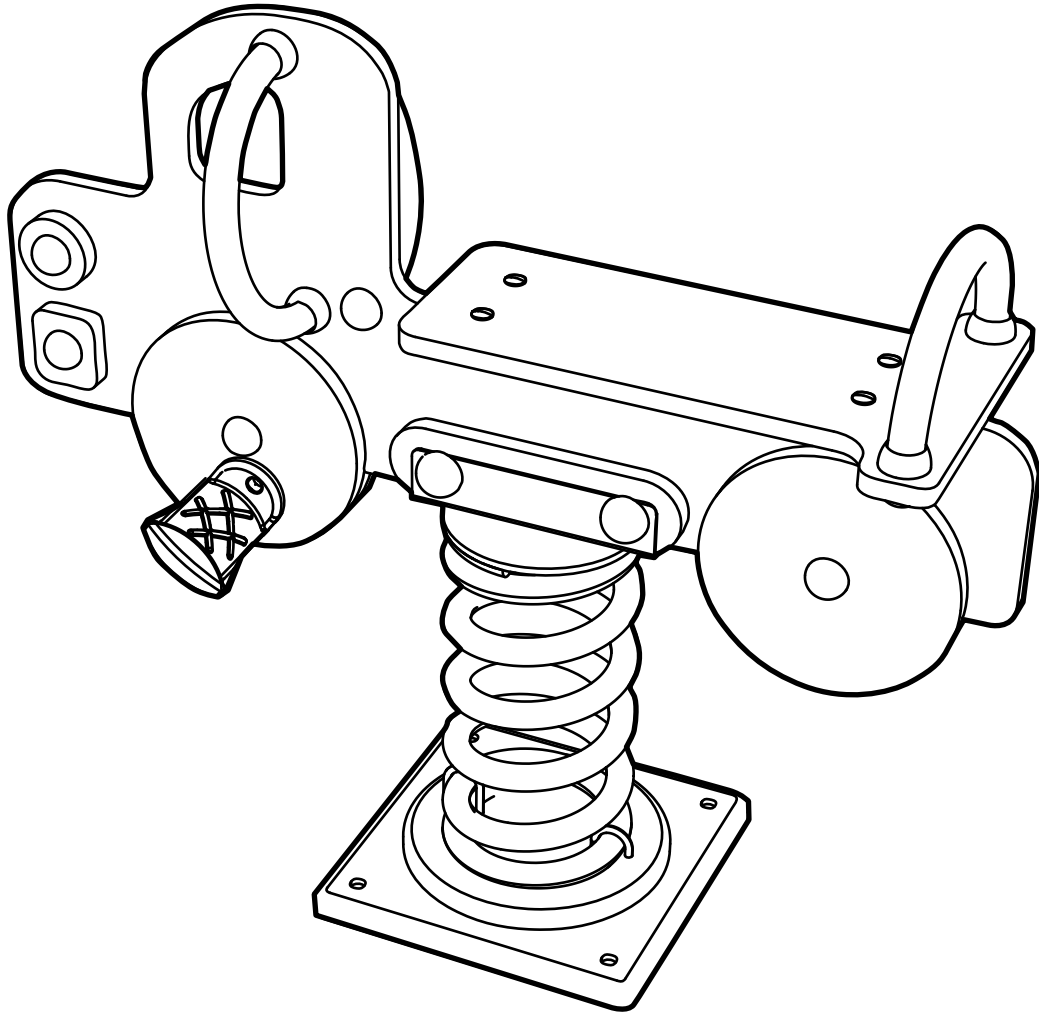

MODEL # 02-07-0054

Truck

Spring Rider

**ASSEMBLY
INSTRUCTIONS**

DETAILS PAGE

FOOTING DETAIL

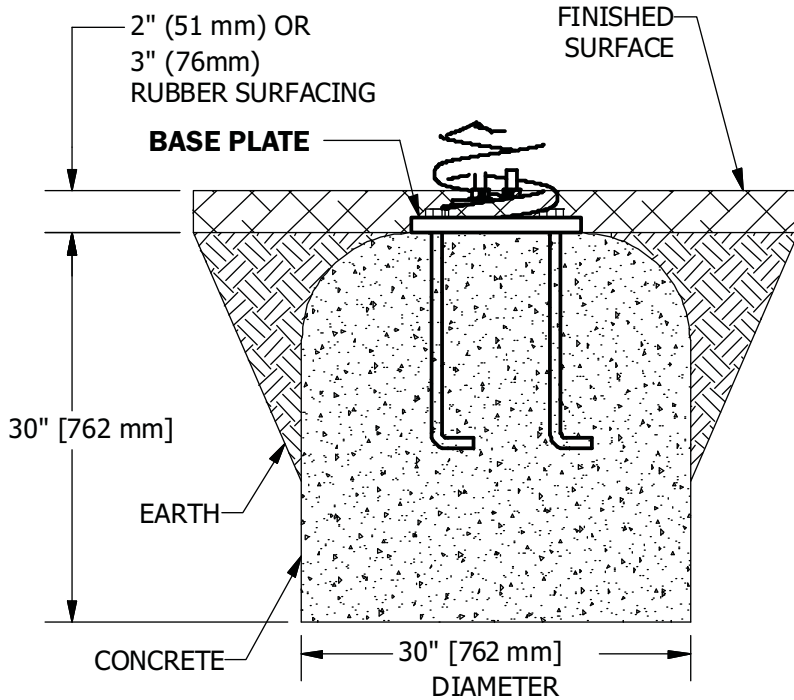

NOTE:

- Hole depths indicated on all ground plans are measured from the finished surface. See Footing Detail.

- All Footer dimensions are based on level finished surface.

Concrete Required :

Approx. .5 Cubic Yards (.35 Cubic Meters)
Suggested Min. concrete rating: 3000PSI

USE ZONE: 15'(4572mm)

Note: Use zones can overlap for sitting type of equipment only if designated play surface height is 30"(762mm) or less.

Spring Riders and See Saw can be placed 6'(152mm) apart.

Top View

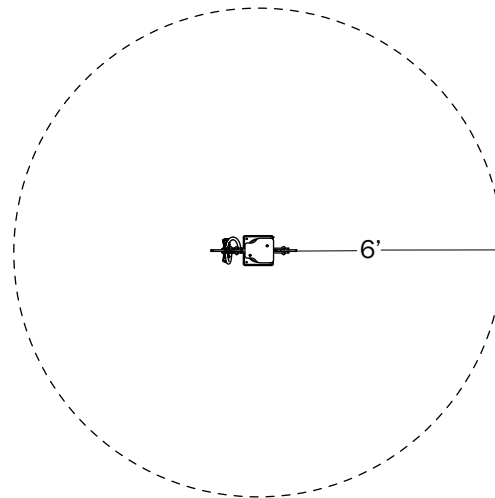

Specifications:

- Panels:** High-density .625(16mm) thick solid polyethylene with color molded in and UV-stabilized.
- Handles:** Formed from 1.0625(30mm) Galvanized Pipe, powder coated after fabrication
- Spring:** Free height 12"(305mm), 6"(152mm) O.D. steel tempered, powder-coated
- Bolt Caps:** Injection Molded polypropylene, UV stabilized
- Brackets:** Formed from 1/8"(5mm) thick steel, powder coated after fabrication
- Hardware:** Primary hardware is stainless steel
- Base:** Steel casting, powder coated after fabrication
- Wt:** 55 lbs.

INSTALLATION INSTRUCTIONS - ANCHOR BOLTS

| Parts List | | | |
|------------|--------------------------|----------|-------------|
| Letter | Description | Quantity | Part Number |
| | Hardware Complete | 1 | 33-12-0064 |
| A | 1/2"x10-1/2" Anchor Bolt | 4 | 33-11-0703 |
| B | 1/2" Flat Washer | 4 | 33-02-0003 |
| C | 1/2" Hex Nut | 4 | 33-01-0004 |

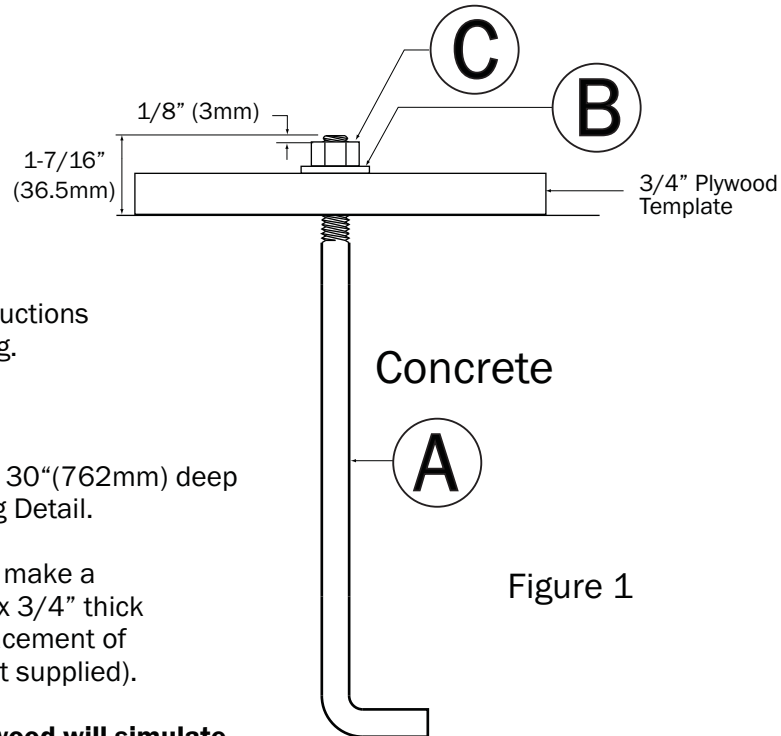

Figure 1

! Read all installation instructions thoroughly before starting.

Instructions:

1. Dig 30" (762mm) diameter x 30" (762mm) deep hole according to the Footing Detail.
2. Use the spring base plate to make a approx. 36" long x 36" wide x 3/4" thick plywood template for the placement of (4) Anchor Bolts (plywood not supplied).

NOTE: Thickness of plywood will simulate thickness of Base Plate until concrete has cured.

3. From center of plywood, mark (4) holes from Base Plate onto plywood and drill 1/2" thru holes.
4. Insert (4) 1/2" Anchor Bolts (A) into holes in plywood and secure with (4) Flat Washers (B) and (4) Hex Nuts (C).

! **Tighten Hex Nuts (C) onto Anchor Bolts until thread extends 1/8" beyond nut . (See Figure 1).**

5. Pour concrete footing and lay template on surface in a level position while forcing anchor bolts into concrete. Allow 72 hours of curing time before removing template.
6. After concrete has cured, loosen and remove Hex Nuts (C) and Flat Washers (B). Remove Plywood Template.
7. Align holes in Base Plate of Spring Rider with Anchor Bolts (A) in concrete.
8. Secure Spring Rider to concrete footer with (4) Flat Washers and (4) Hex Nuts.

INSTALLATION INSTRUCTIONS - INGROUND FOOTER

| Parts List | | | |
|------------|--------------------|----------|-------------|
| Letter | Description | Quantity | Part Number |
| A | In-ground Footer | 1 | 02-07-0081 |
| B | 3/8" x 1-1/4" Bolt | 4 | 33-02-0003 |
| C | 3/8" Flat Washer | 8 | 33-02-0002 |
| D | 3/8" Hex Nut | 4 | 33-01-0002 |

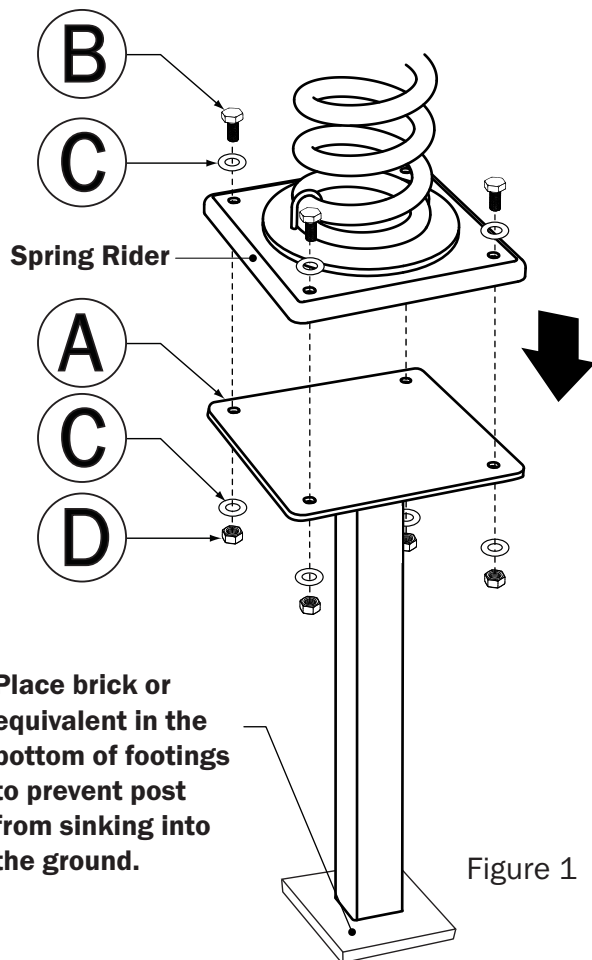

Place brick or equivalent in the bottom of footings to prevent post from sinking into the ground.

Figure 1

Concrete Required :

Approx. .3 Cubic Yards (.25 Cubic Meters)
Suggested Minimum concrete rating: 3000PSI

IMPORTANT: Never install play equipment over hard, unresilient surfaces such as asphalt, concrete or compacted earth. It is the owner's responsibility to ensure the "minimum area required" contains an appropriate amount of resilient material to cushion accidental falls.

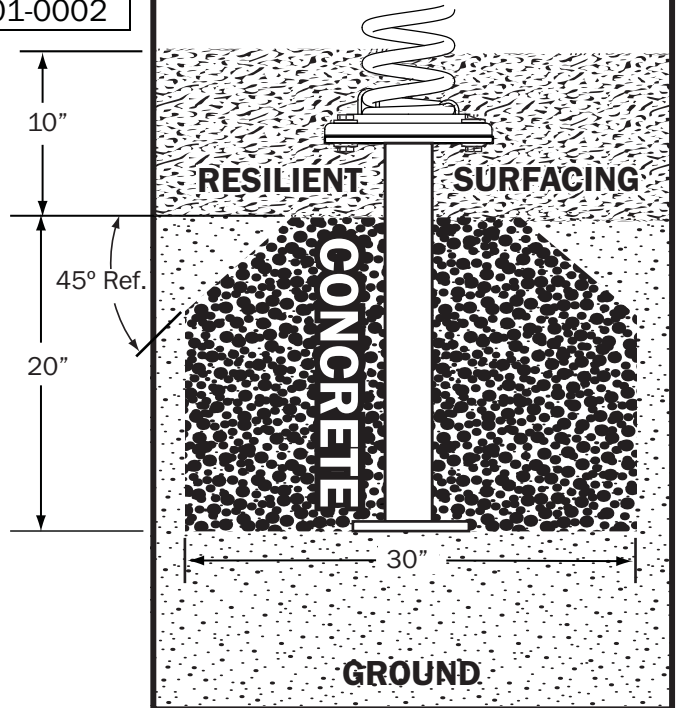

Instructions:

1. Dig a 30"(762mm) Diameter x 20"(508mm) deep hole.
Note: Depth of hole can increase to accommodate appropriate surfacing height.
2. Place brick or equivalent into bottom of hole and place In-ground footer(A) into the center of hole.
3. Fill hole with concrete.
4. Plumb and level In-ground Footer(A).

Note: Allow 72 hours of curing time before securing spring rider to In-ground Footer(A).

5. Once concrete has cured, secure Spring Rider and Inground Footer(A) together using (4) 3/8" x 1-1/4" Bolts(B), (8) 3/8" Flat Washers(C) and (4) 3/8" Hex Nuts(D). See Figure 1.