

Model #238HS-EV8

## **SAFETY WARNINGS & EQUIPMENT INSPECTION**

- Owners and installers please note these safety warnings and make use of this checklist on a regular basis.
- Follow installation instructions when erecting equipment.
- Ground surfaces around equipment should be restored as needed. Concrete footings should never be exposed. Surface depth should comply with ASTM and CPSC specifications.
- Check for and repair damage caused by wear or vandalism, a major factor in injury causing situations.
- All protruding bolts should be covered or cut off and finished smooth. Sharp edges on pipes should be capped or removed. Check for bent, broken, or severely worn pipe, and replace.
- All equipment should be free of rust and repainted whenever necessary to deter rusting.
- We provide our customers with layout sheets and installation instructions. Please keep on file the specifications sheet that contains the listing of every part used.
- Never add components not intended for use with this product.
- Regular maintenance is necessary in this and all park and recreational equipment to insure the safety of the user.
- Note: Proper maintenance of equipment requires regular tightening of all bolts, nuts, and setscrews.
- Note: Regular checking of all parts, castings, etc. should be made. If a part is broken or worn, it should be replaced immediately.
- Check to be sure all fittings are tight and that bars and pipes do not move.
- Replace all worn S-hooks. S-hooks must be completely closed. Failure to close S-hooks can result in serious injury to the user. NEVER reuse S-hooks.
- Test for free movement of swing hanger and other moving attached parts.
- Check for worn chains and replace them.
- A soft resilient surface should be placed under all swings extending at least twice the height of the top rail both front and back.

# HARDWARE

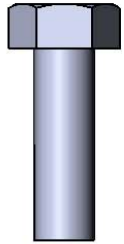

5/16" x 1"  
Machine Bolt

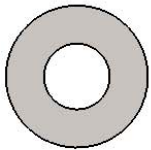

5/16" Washer



5/16" Kep Nut

## TOOLS REQUIRED

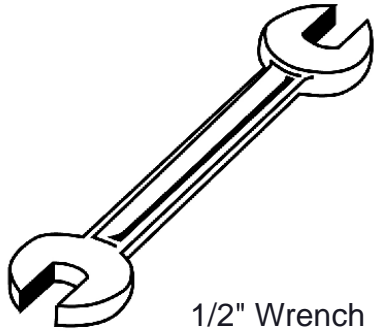

1/2" Wrench

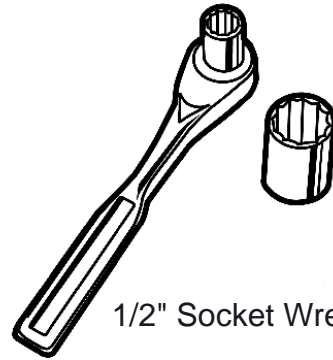

1/2" Socket Wrench

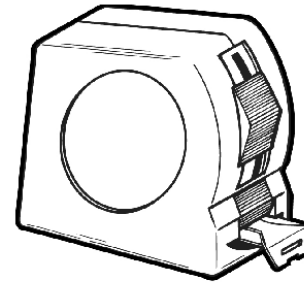

Tape Measure

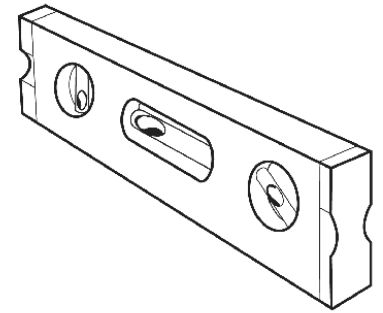

Level

## PRODUCT SPECIFICATIONS

### **238HS-EP8 8' ACCESSIBLE PICNIC TABLE WALK-THROUGH DESIGN**

Top & Seats: 11 gauge die formed angle frame 1"x1-7/8" with 3" radius corners. Seat plates are fabricated from a 12ga plate. Top plate is fabricated from 9ga plate. Holes are precision punched at 3/4" diameter. 10 gauge x 1-1/2" flat bar center support and mounting bracket understructure. Electrically MIG welded.

Coating: Oven fused functionalized polyethylene copolymer-based thermoplastic. Fluidized bed coating application with superior mechanical performance, impact resistance and UV-stability.

Frame: 2-3/8" O.D. x 12 gauge pre-galvanized structural steel tubing. Cross braces 1" O.D. x 16 gauge pre-galvanized structural steel tubing. Brace attachment points 1-1/2"x1-1/2"x3/16" steel angle. Seat and top mounting points 7 gauge x 1-1/2" die stamped steel flat bar. Legs are bent over a mandrel through the bend radius producing a wrinkle free bend. All electrically MIG welded.

Frame Coating: Electrostatic powder coated application oven cured.

Hardware: All stainless steel hardware fasteners.

Dimensions: 8' accessible picnic table walk-through design. Top is 30" wide x 96" long and is 30-1/4" high. Seats are 10" wide x 72" long and 18-1/2" high. Outside to outside dimension is 66-1/2" x 96". The table over hangs the frame 33" on one end.

# COMPONENTS

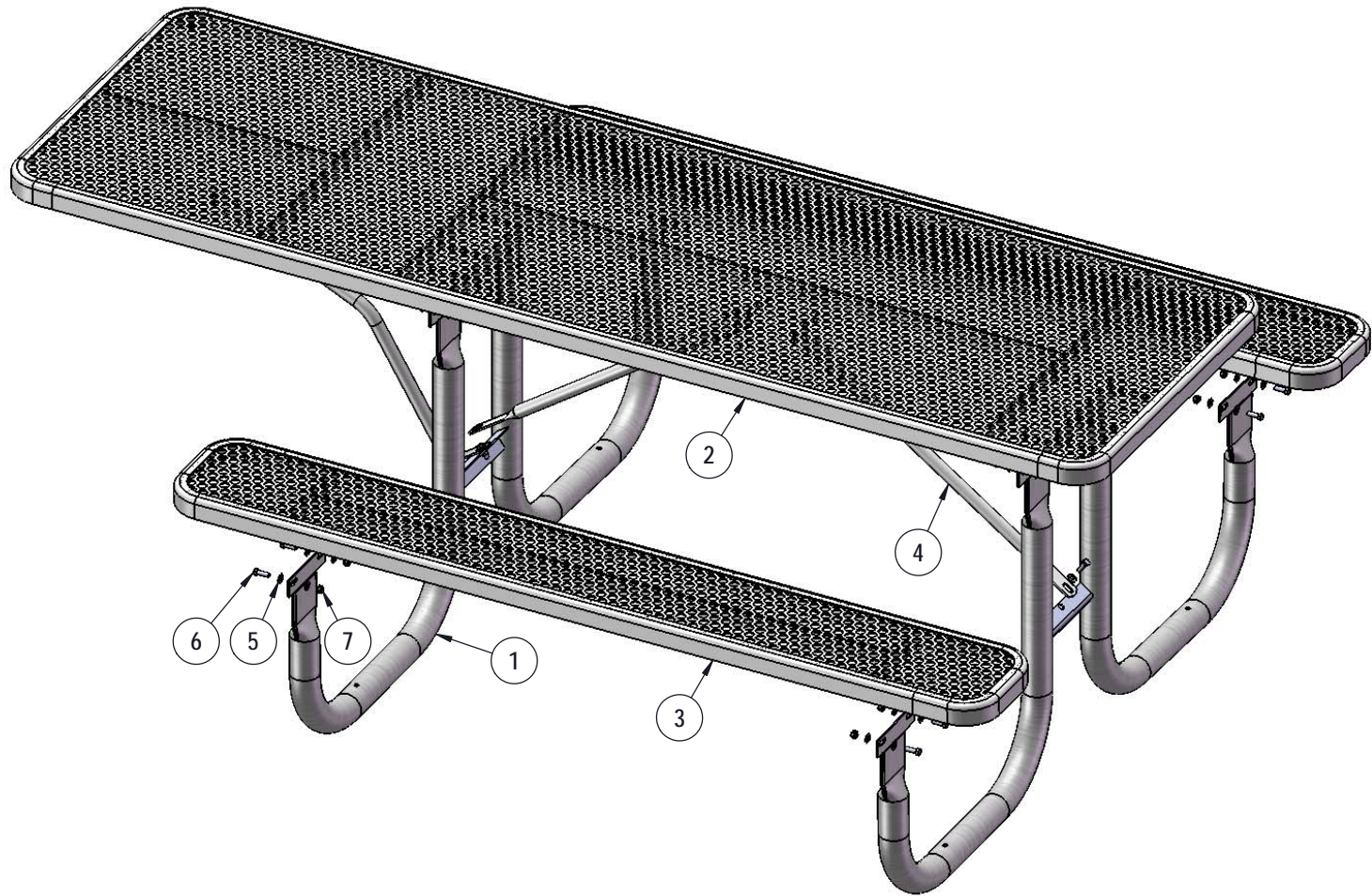

ITEM NO.	PartNo	DESCRIPTION	QTY
1	P-V238	238 Vinyl Frame	2
2	T-P96HS-T	8' HS perf top	1
3	T-EP72-S	6' x 10" perf seat	2
4	P-01-04-0125	29 7/8" Brace	2
5	33-02-0007	5/16" SS Washer	42
6	33-05-0029	5/16" x 1" Machine Bolt (SS)	21
7	33-03-0012	5/16" Kep Nut (SS)	21
8	P-01-04-0148	158/238 HS Brace	1

Optional Surface Mount Hardware:  
5/16" x 5-1/2" Concrete Expansion Anchor Bolts  
(Not Included)

# STEP 1

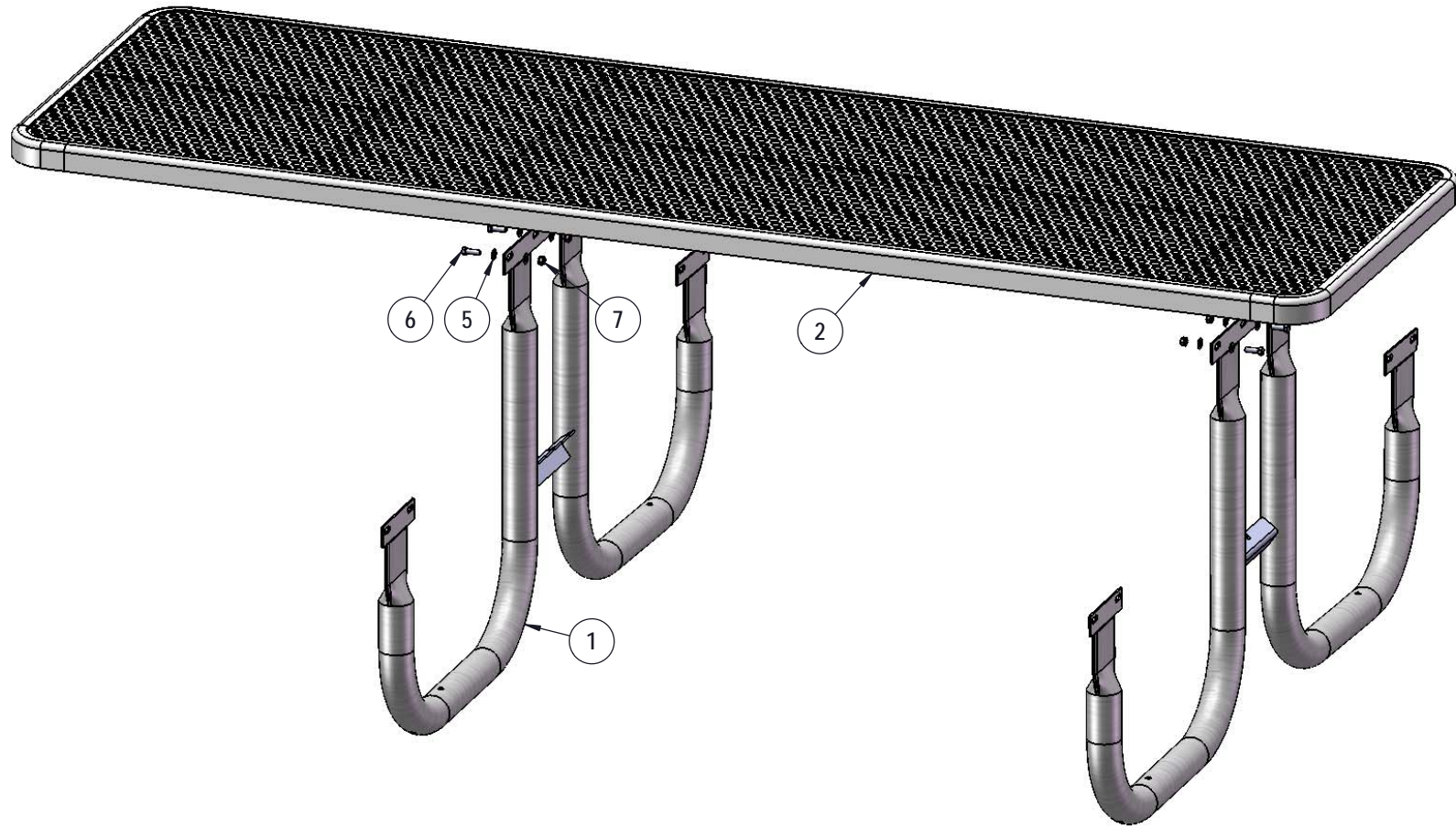

Attach the 8' Top to the 238 Legs using specified hardware.

## STEP 2

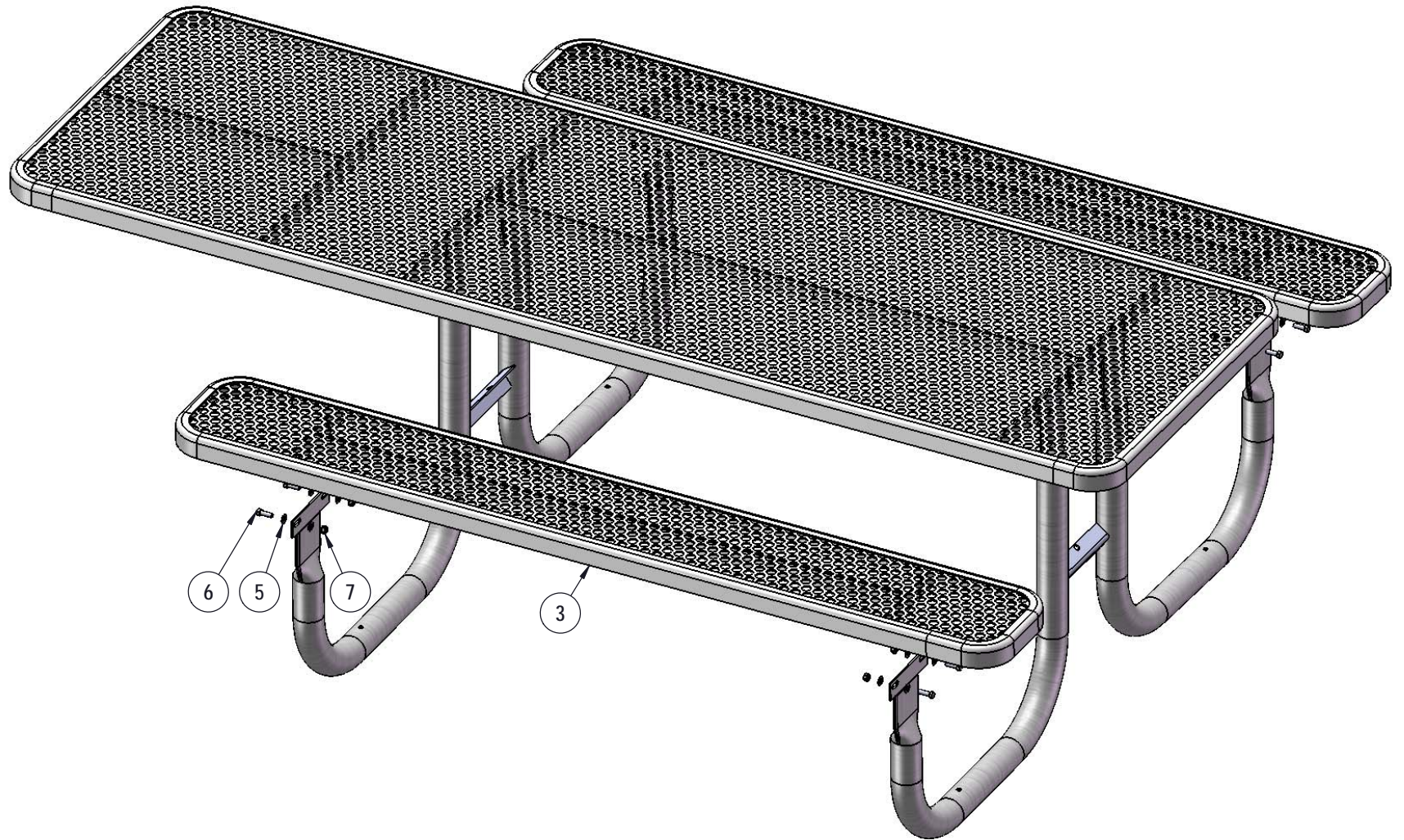

Attach the 6' Seats to the 238 Legs using specified hardware.



## STEP 3

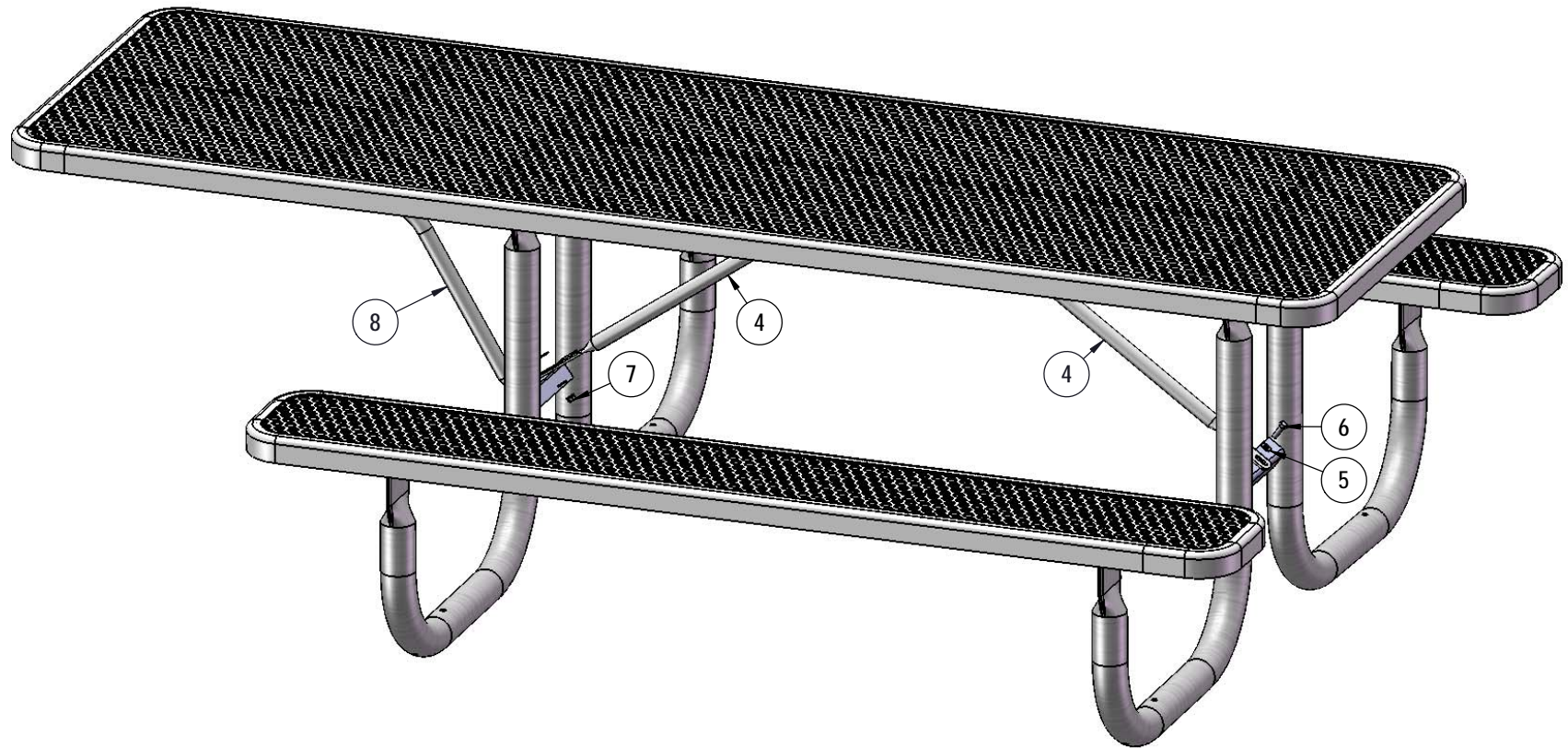

Attach the 29 7/8" braces and the 158/238 Brace to the 238 Legs using specified hardware.

# OVERALL DIMENSIONS

