



Model # 358-RDEP

## **SAFETY WARNINGS & EQUIPMENT INSPECTION**

- Owners and installers please note these safety warnings and make use of this checklist on a regular basis.
- Follow installation instructions when erecting equipment.
- Ground surfaces around equipment should be restored as needed. Concrete footings should never be exposed. Surface depth should comply with ASTM and CPSC specifications.
- Check for and repair damage caused by wear or vandalism, a major factor in injury causing situations.
- All protruding bolts should be covered or cut off and finished smooth. Sharp edges on pipes should be capped or removed. Check for bent, broken, or severely worn pipe, and replace.
- All equipment should be free of rust and repainted whenever necessary to deter rusting.
- We provide our customers with layout sheets and installation instructions. Please keep on file the specifications sheet that contains the listing of every part used.
- Never add components not intended for use with this product.
- Regular maintenance is necessary in this and all park and recreational equipment to insure the safety of the user.
- Note: Proper maintenance of equipment requires regular tightening of all bolts, nuts, and setscrews.
- Note: Regular checking of all parts, castings, etc. should be made. If a part is broken or worn, it should be replaced immediately.
- Check to be sure all fittings are tight and that bars and pipes do not move.
- Replace all worn S-hooks. S-hooks must be completely closed. Failure to close S-hooks can result in serious injury to the user. NEVER reuse S-hooks.
- Test for free movement of swing hanger and other moving attached parts.
- Check for worn chains and replace them.
- A soft resilient surface should be placed under all swings extending at least twice the height of the top rail both front and back.

# HARDWARE

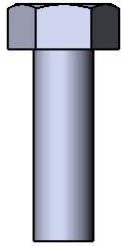

5/16" x 1"  
Machine Bolt

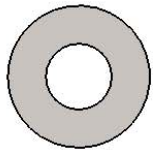

5/16" Washer

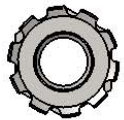

5/16" Kep Nut

## TOOLS REQUIRED

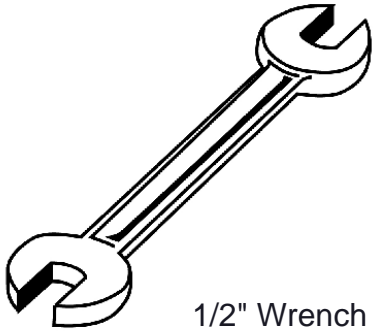

1/2" Wrench

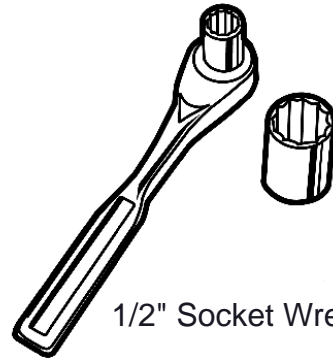

1/2" Socket Wrench

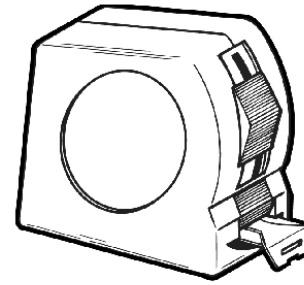

Tape Measure

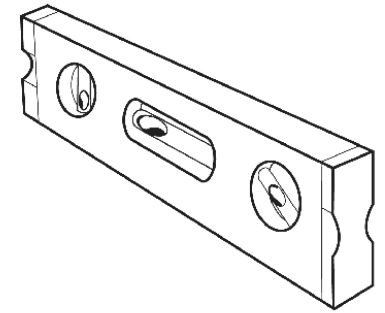

Level

# PRODUCT SPECIFICATIONS

## **358-RDEP 46" ROUND PORTABLE TABLE WITH 4 SEATS**

Top & Seats: 11 gauge die formed angle frame 1"x1-7/8" with 3" radius on the seat corners. A 14 gauge piece of sheet steel is precision punched with a 5/8" hole to create the punched hole pattern for the seats. The top uses a 9ga sheet with 3/4" hole pattern. The understructure/attachment plates are fabricated from 10 gauge x 1-1/2" flat bar. Top is additionally supported to the outer frame with 10 gauge x 1-1/2" flat bar. Electrically MIG welded.

Coating: Oven fused functionalized polyethylene copolymer-based thermoplastic. Fluidized bed coating application with superior mechanical performance, impact resistance and UV-stability.

Frame: 1-5/8" O.D. x 14 gauge pre-galvanized structural steel tubing. Brace attachment points are 1-1/2"x2"x3/16" steel flat bar. Cross braces 1" O.D. x 16 gauge pre-galvanized structural steel tubing. Top is attached with 7 gauge 2"x2" die formed angle. Seat mounting points are 7 gauge x 1-1/2" die stamped steel flat bar. Legs are bent over a mandrel through the bend radius producing a wrinkle free bend. All electrically MIG welded.

Frame Coating: Electrostatic powder coated application oven cured.

Hardware: All stainless steel hardware fasteners.

Dimensions: Top is 46" round x 30-1/4" high. Seats are 12" wide x 44-1/2" long x 18" high. Outside to outside dimensions of 4 seat table is 83" round.

# COMPONENTS

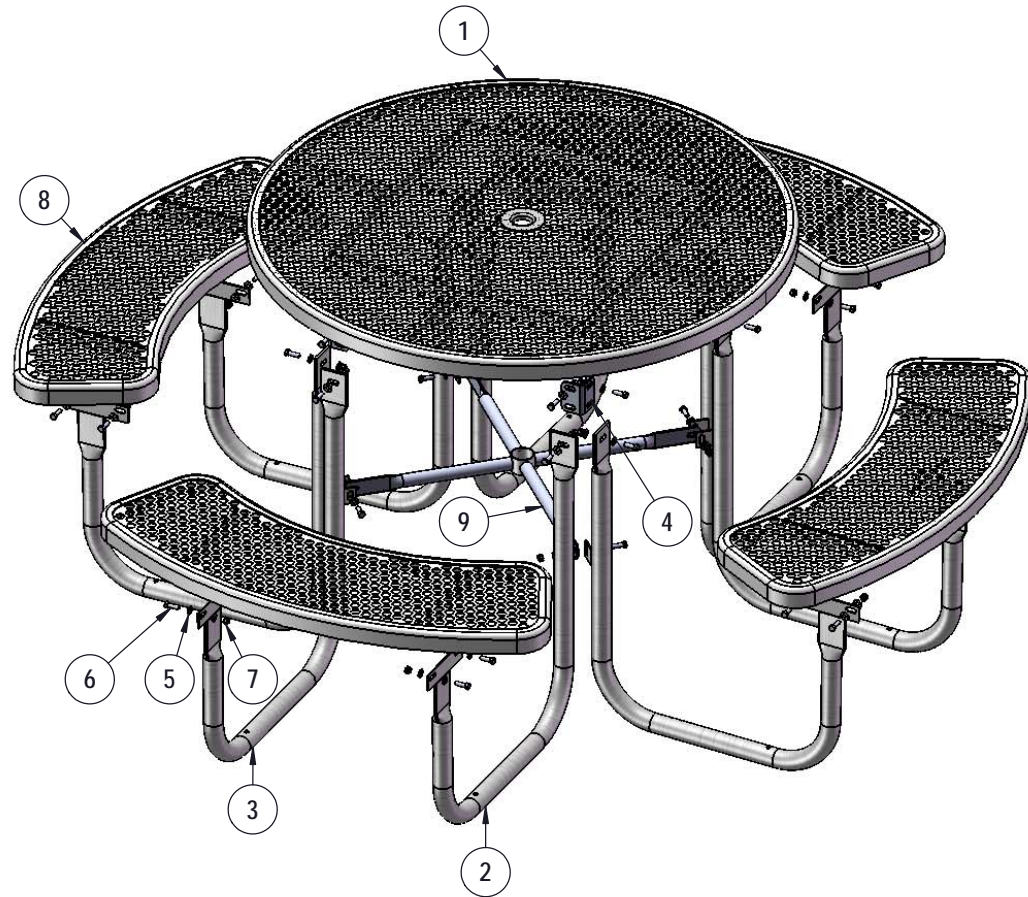

ITEM NO.	PartNo	DESCRIPTION	QTY
1	T-EP46RD-T	46" Round Economy Punched Top	1
2	P-V358-R	358 Vinyl Leg R	4
3	P-V358-L	358 Vinyl Leg L	4
4	P-01-04-0121	358 Extension Tab	4
5	33-02-0007	5/16" SS Washer	72
6	33-05-0029	5/16" x 1" Machine Bolt (SS)	36
7	33-03-0012	5/16" Kep Nut (SS)	36
8	T-EP36RD-S	3' Punched Round Seat	4
9	P-01-04-0122	358 Crossbrace w/ Umbrella Tube	1

# STEP 1

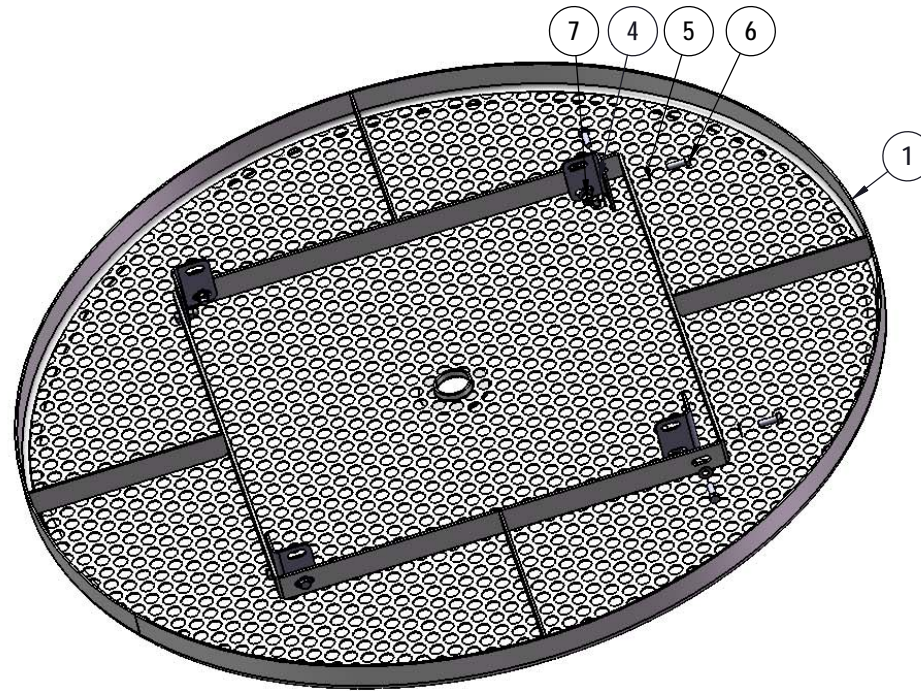

Attach the Extension Tabs to the 46" Round Top using the specified hardware.

## STEP 2

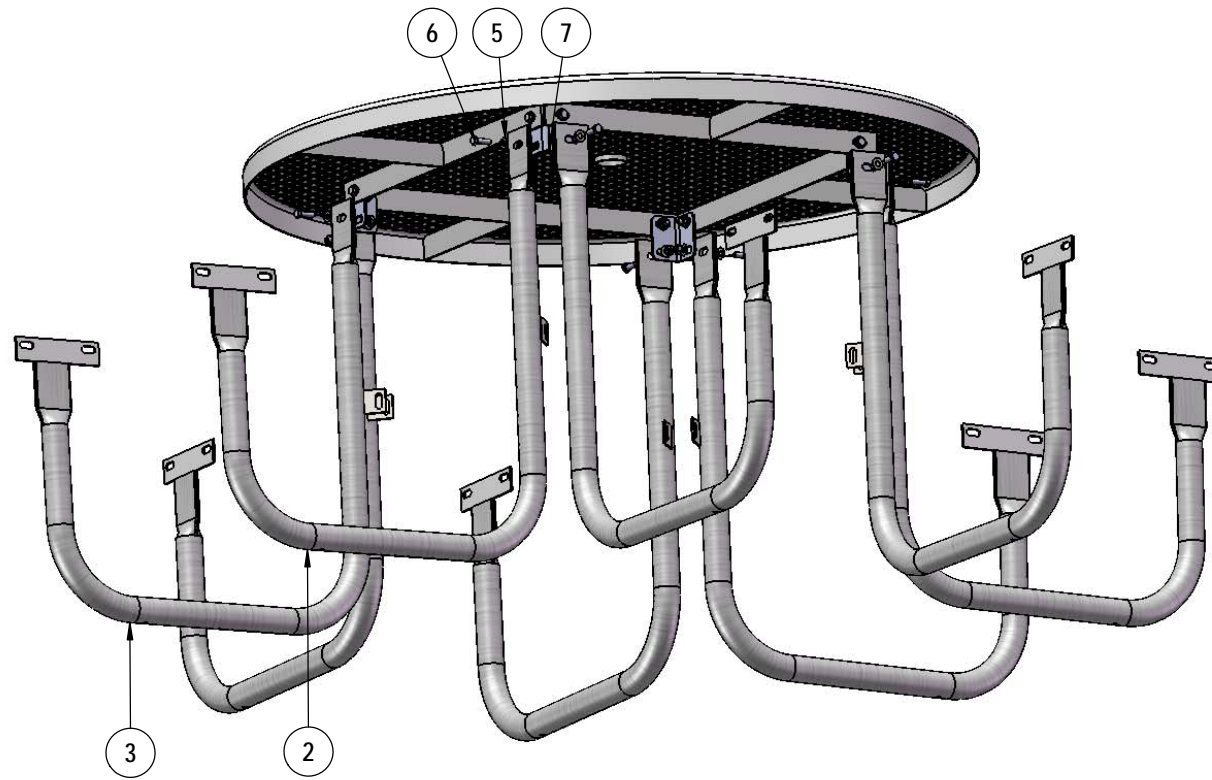

Attach the 358 Legs to the outside of the Extension Tabs using the specified hardware.



## STEP 3



Attach the Crossbrace between the table legs as shown using the specified hardware.

## STEP 4



Attach the 3' Seats to the 358 Legs using the specified hardware.

# OVERALL DIMENSIONS

