

Capsule Pressure Gauges Process Industry Series Type 632.50 - Dry Case Type 633.50 - Liquid-filled Case

WIKA Datasheet 63X.50

Applications

- Robust design and weather protection, suitable for outdoor use
- Suitable for dry, gaseous media that will not attack 316 stainless steel parts
- Process industry: chemical/petrochemical, power stations, mining, on and offshore, environmental technology, mechanical engineering and plant construction

Special features

- Zero-adjustment through window
- All stainless steel construction
- Low pressure ranges from 1" H₂O to 275" H₂O

Standard Features

Design

ASME B40.100 & EN 837-3

Sizes

2½", 4" & 6" (63, 100 and 160 mm)

Accuracy class

±1.5% of span

Ranges

2½": 16 "H₂O to 275 "H₂O (40 to 685 mbar)

4": 10 "H₂O to 275 "H₂O (16 to 685 mbar)

6": 1 "H₂O to 275 "H₂O (2.5 to 685 mbar)

or other equivalent units of pressure or vacuum

Working pressure

Steady: full scale value

Fluctuating: 0.9 x full scale value

Operating temperature

Ambient: -4°F to +140°F (-20°C to +60°C)

Medium: +212°F (+100°C) maximum

Temperature error

Additional error when temperature changes from reference temperature of 68°F (20°C) ±0.6% for every 18°F (10°C) rising or falling. Percentage of span.



Capsule Element Pressure Gauge Model 632.50

Weather protection

Weather resistant (NEMA 3 / IP54)

Pressure connection

Material: 316L stainless steel

Lower mount (LM) or center back mount (CBM) - 2½"

Lower mount (LM) or lower back mount (LBM) - 4" & 6"

1/4" NPT or 1/2" NPT limited to wrench flat area

Capsule element

Material: 316L stainless steel with Viton sealing ring

Movement

Stainless steel

Dial

White aluminum with black lettering

Pointer

Black aluminum

Case

304 stainless steel with stainless steel bayonet ring

Window

Laminated safety glass

Case fill

Glycerine/Water or Silicone - Type 633.50

(only available for full scale ranges ≥ 40" H₂O)

Optional extras

- Other pressure connections
- ±1.0% accuracy (ASME B40.100 Grade 1A)
- SS front flange
- U-clamp mounting, SS
- Silicone or fluorolube case filling
- Over and underpressure protection
- Special connections limited to wrench flat area
- Custom dial layout

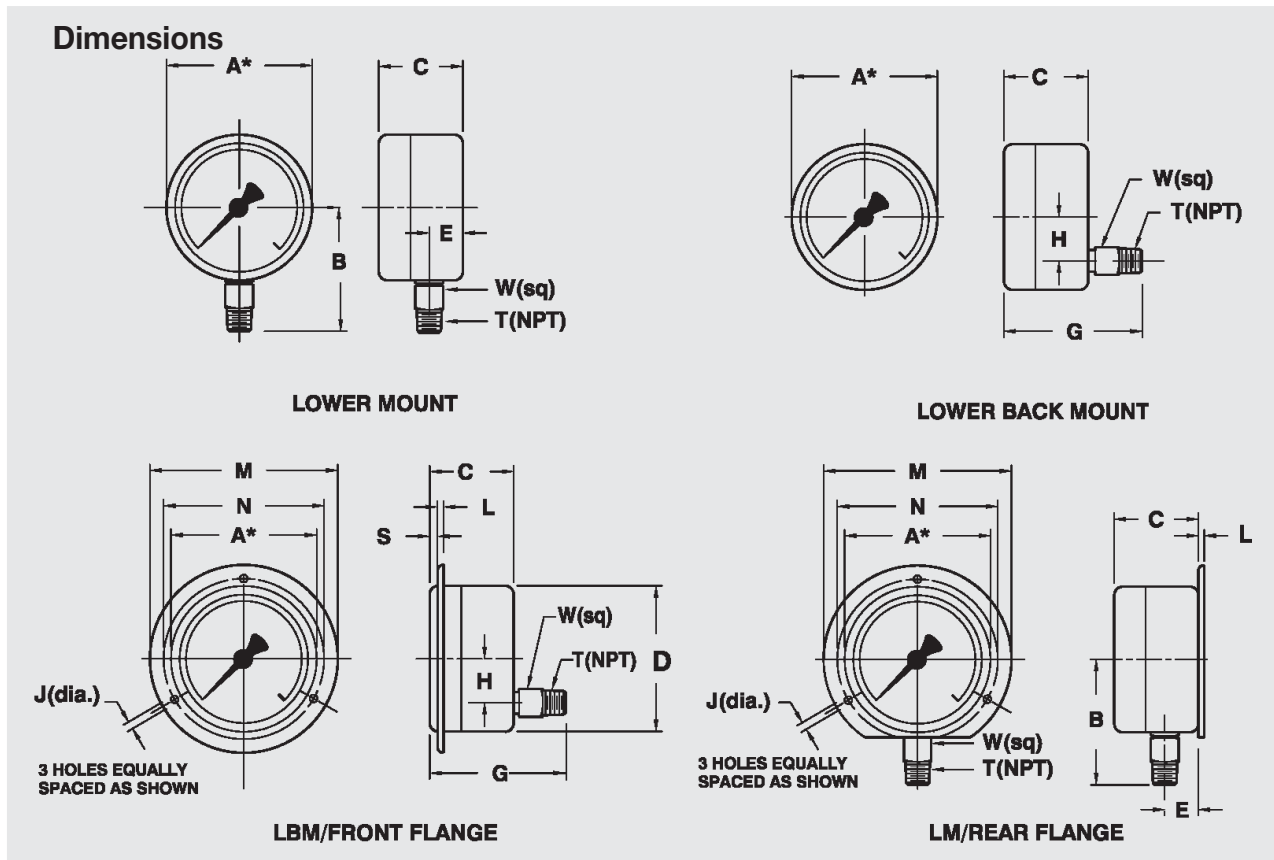

Size		A	B	C	D	E	G	H ¹	J	L	M	N	S	T	W	Weight ²
2.5"	mm	63	51	42	62	9	58	0	4	3	85	75	5		14	
	in	2.5	2.0	1.65	2.44	0.35	2.28	0	0.14	0.12	3.35	2.95	0.2	1/4"	0.55	0.41 lb.
4"	mm	100	85	49.5	99	15.5	78	30	4.8	3	132	116	5		22	
	in	4.0	3.35	1.95	3.9	0.61	3.07	1.18	0.19	0.12	5.20	4.57	0.2	1/2"	0.86	1.32 lb.
6"	mm	160	116	49.5	159	15.5	78	50	5.8	3	196	178	5		22	
	in	6.0	4.57	1.95	6.26	0.61	3.07	1.97	0.23	0.12	7.72	7.0	0.2	1/2"	0.86	2.42 lb.

¹ For size 2.5", connection is center back mount (CBM)

² Weight without optional accessories

