

POWERED MAST OPTION (RETROFIT) - SWA-5070LP-PMO-RF

APPROX WEIGHT: 113.48 lbs.
 DOES NOT INCLUDE WEIGHT OF POWER OR PACKAGING!!!

ANY ADDITIONS, DELETIONS, OR OMISSIONS MUST BE CORRECTED ON THIS DRAWING AS THIS DRAWING WILL BE CONSIDERED ALL INCLUSIVE

FOR INTERNAL USE ONLY PROJECT SIGN OFF	
SALES	
ENG.	
FAB.	
POWER	

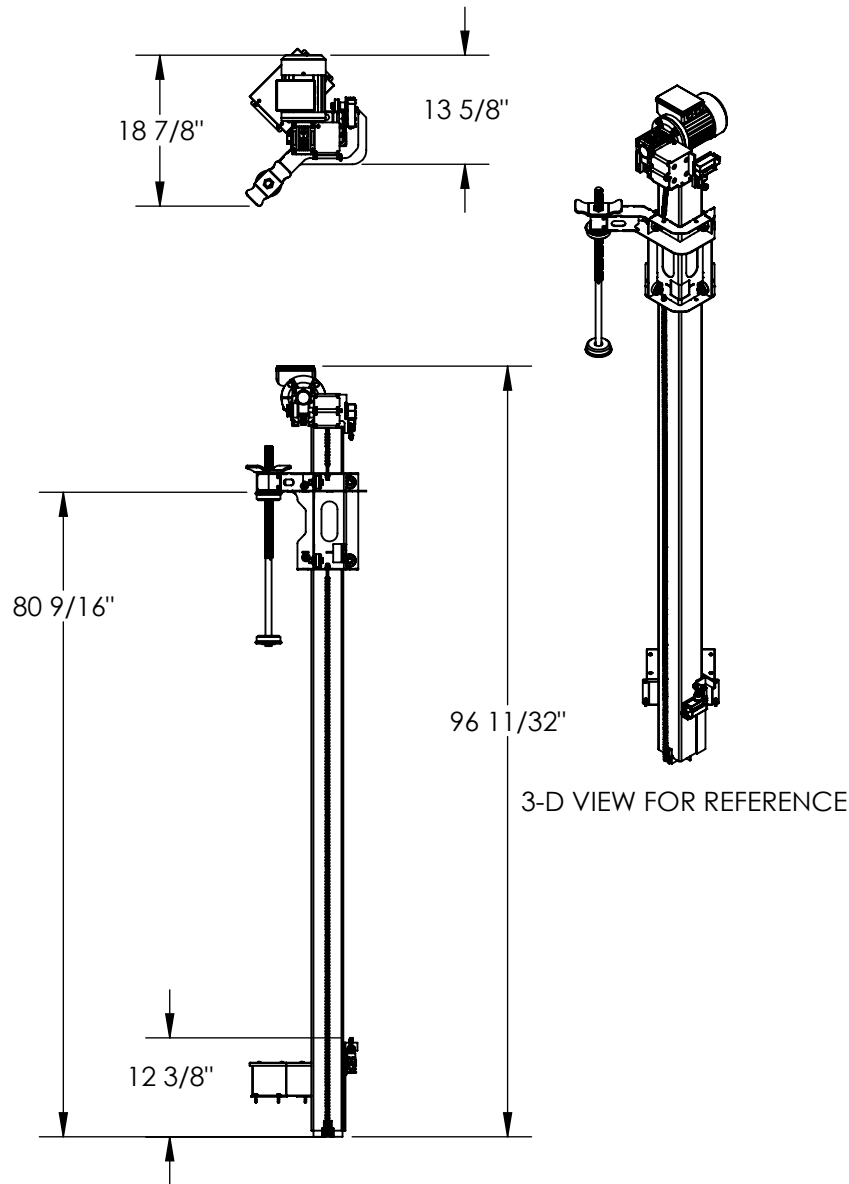

COLOR SPECIFICATIONS

FRAME IS TOUGH BAKED IN POWDER COATED BLUE FINISH

CARRIAGE IS TOUGH BAKED IN POWDER COATED YELLOW FINISH

STANDARD FEATURES

MODEL NUMBER IS SWA-5070LP-PMO-RF
 OVERALL WIDTH IS 18 7/8"
 OVERALL HEIGHT IS 96 11/32"
 WRAP HEIGHT IS 80 9/16"
 HAND CONTROLLED

POWER SPECIFICATIONS

AC POWER
 MOTOR VOLTAGE: 115V
 MOTOR PHASE: SINGLE
 CONTROL: HAND

SPECIAL FEATURES

NONE

ALL GRAPHICS PROVIDED ARE FOR REFERENCE ONLY. IF CERTAIN DIMENSIONS ARE CRITICAL PLEASE VERIFY THOSE DIMENSIONS WITH YOUR SALESPERSON

DIMENSION TOLERANCE ± 1/4"

APPROVAL	I, THE UNDERSIGNED, AGREE THAT THE PRODUCT AS REPRESENTED SATISFIES DESIGN AND DIMENSION REQUIREMENTS. I ALSO ACKNOWLEDGE MY DUTY TO CONFIRM PRODUCT AND INSTALLATION COMPLIANCE WITH ALL APPLICABLE FEDERAL, STATE AND LOCAL REGULATIONS AND STANDARDS.	
	ANY MODIFIED UNITS ARE NON-RETURNABLE	
	[] As drawn [] As marked	
	Signed: _____	Date: _____
Printed Name: _____		
LEAD TIME WILL START UPON RECEIPT OF SIGNED APPROVAL DRAWING		

DISTRIBUTOR'S NAME:		P.O.#
VESTIL MANUFACTURING		X
DRAWN BY: SJA		DATE: 2/2/2015
REFERENCE: X		SCALE: 1:24
QUOTED LEAD TIME: X	QUOTE #	FILE NAME:
	X	20-007-115