

Description

The Wesco Poly Jaws Drum Grab is designed specifically for transporting 55 gallon and 30 gallon poly drums with a powered fork truck.

This product is distributed by:

Wesco Industrial Products, Inc
1250 Welsh Road
North Wales, PA 19454
Tel: 215-699-7031 Fax: 215-699-3836

Contact the factory for parts information and ordering.
Visit us on the web at www.wescomfg.com

Unpacking

When unpacking the Wesco Product, check carefully for shipping damage and missing parts. If damage has occurred or any parts are missing, file a claim with the delivering carrier within 24 hours and notify the dealer from whom the unit was purchased.

Warranty Repairs

If the unit does not work properly, contact your dealer or the factory (215-699-7031) for units less than 90 days old.

Non-Warranty Service

If units are older than 90 days, repairs can be made easily on site with factory supplied parts.

NOTE: Do not send units to the factory for service without first obtaining a "Return Merchandise Authorization" (RMA) number from the customer service department. We will not be responsible for merchandise returned without proper authorization.

General Safety Information

Warning: The Wesco Poly Jaws Drum Grab is designed for specific functions. To insure proper use, the following instructions must be adhered to:

- (4) Maximum capacity – 30 Gallon Drum 800 lbs.
– 50 Gallon Drum 1,000 lbs.
- (5) DO NOT exceed rated capacity. Injury to persons or property may result from overloading and misuse.

General Safety Information (cont'd)

- (3) DO NOT use to lift distorted, out-of round or keg (egg-shaped) drums.
DO NOT USE UNIT TO HANDLE STEEL DRUMS.
- (4) DO NOT use drum grab with manually operated stackers.
- (5) DO NOT carry loads over people.
- (6) DO NOT leave unit unattended with load suspended in air.
- (7) DO NOT remove or obscure warning label.
- (8) Grippers must be placed securely under drum lip.
- (9) Use only on poly drums with extended top lip of at least 3/16".
- (10) Follow all Occupational Safety and Health Act (OSHA) requirements particularly Section 1910.178a(5) regarding powered industrial trucks.
- (11) Adhere to all local codes regarding drum use and storage.
- (12) Inspect unit before use. Remove unit immediately from service if damage or malfunctioning, until repairs have been made.
- (13) DO NOT modify this product in any way.

Maintenance

- (1) Lubricate moving parts periodically. Pay special attention to gear, they should be greased at all times.
- (2) Check bolts and nuts frequently for tightness.



Figure 1

LIMITED WARRANTY

WESCO INDUSTRIAL PRODUCTS (WESCO) warrants to the purchaser of this product for a period of ninety (90) days from the date of purchase that this product shall be free of defects in material and/or workmanship, as follows:

1. WESCO will supply, at no charge, new or rebuilt replacements for any part that fails through a defect in material and/or workmanship during the warranty period. To obtain warranty service, you must deliver the product prepaid, to the WESCO factory.

2. This warranty does not cover any product or product part which has been subject to accident, misuse, abuse or negligence. WESCO shall only be liable under this warranty if the product is used the manner intended by the manufacturer as specified in the written instructions furnished with this product.

REPAIR OR REPLACEMENT AS PROVIDED UNDER THIS WARRANTY IS THE EXCLUSIVE REMEDY OF THE PURCHASER. ANY EXPRESS WARRANTY NOT PROVIDED IN THIS WARRANTY DOCUMENT, AND ANY REMEDY FOR BREACH OF CONTRACT THAT, BUT FOR THIS PROVISION, MIGHT ARISE BY IMPLICATION OR OPERATION OF LAW, IS HEREBY EXCLUDED AND DISCLAIMED. UNDER NO CIRCUMSTANCES SHALL WESCO BE LIABLE TO PURCHASER OR ANY OTHER PERSON FOR ANY INCIDENTAL OR CONSEQUENTIAL DAMAGES, WHETHER ARISING OUT OF BREACH OF WARRANTY, EXPRESS OR IMPLIED, A BREACH OF CONTRACT OR OTHERWISE. EXCEPT TO THE EXTENT PROHIBITED BY APPLICABLE LAW, ANY IMPLIED WARRANTY OF MERCHANTABILITY AND FITNESS FOR ANY PARTICULAR PURPOSE ARE EXPRESSLY LIMITED IN DURATION TO THE DURATION OF THIS LIMITED WARRANTY.

Some states do not allow the exclusion or limitation of incidental or consequential damages, or allow limitations on how long any implied warranty lasts, so the above limitations may not apply to you. This warranty gives you specific legal rights, and you may also have other rights which vary from state to state.

Spare Parts List

Item	Part No.	Description	Qty.	Item	Part No.	Description	Qty.
1	054380	Fork-RH	1	6	054079	Clamp Handle	2
2	054381	Fork-LH	1	7	108924	Compression Spring	1
3	054391	Adjustable Tube	1	8	108922	Gripper Spring-RH	1
4	054392	Barrel Stop	1	9	108923	Gripper Spring-LH	1
5	054393	Barrel Gripper	2	10	108925	Lynch Pin	1

Operation Instructions

Numbers in parenthesis refer to Spare Parts List above

- (1) Mount Barrel Stop (4) to Adjustable Tube (3) with 5/16-18x3" bolt, Compression Spring (7) and jam nut.
Note: For 55 gallon drum stop should be mounted with long leg towards rear of unit; for 30 gallon drum stop should be mounted with long leg towards front of unit.
- (2) Using 3/8-16x2" long bolt, washer, and hex nut mount adjustable tube to Left Hand Fork (2). Tighten hardware.
- (3) Slide Adjustable Tube (3) into Right Hand Fork (1) and insert Lynch Pin (10) in desired location (outside hole position for 55 gallon drums; inside hole location for 30 gallon drums).
- (4) Attach Barrel Grippers (5) to fork arms using 1/2"-13x3" socket head bolts and locknuts. The Gripper Springs (8 & 9) are mounted between the fork arms and the barrel gripper. The long extension of the springs should be mounted on the inside of the fork arms, and the short extension of the springs inserted into the small mounting hole in the bottom of the barrel grippers. Tighten 1/2" bolts while centering gripper over fork arm, then back nut off 1/4 turn to allow gripper to move freely with spring tension.
- (5) Thread Clamp Handles (6) into left and right hand forks

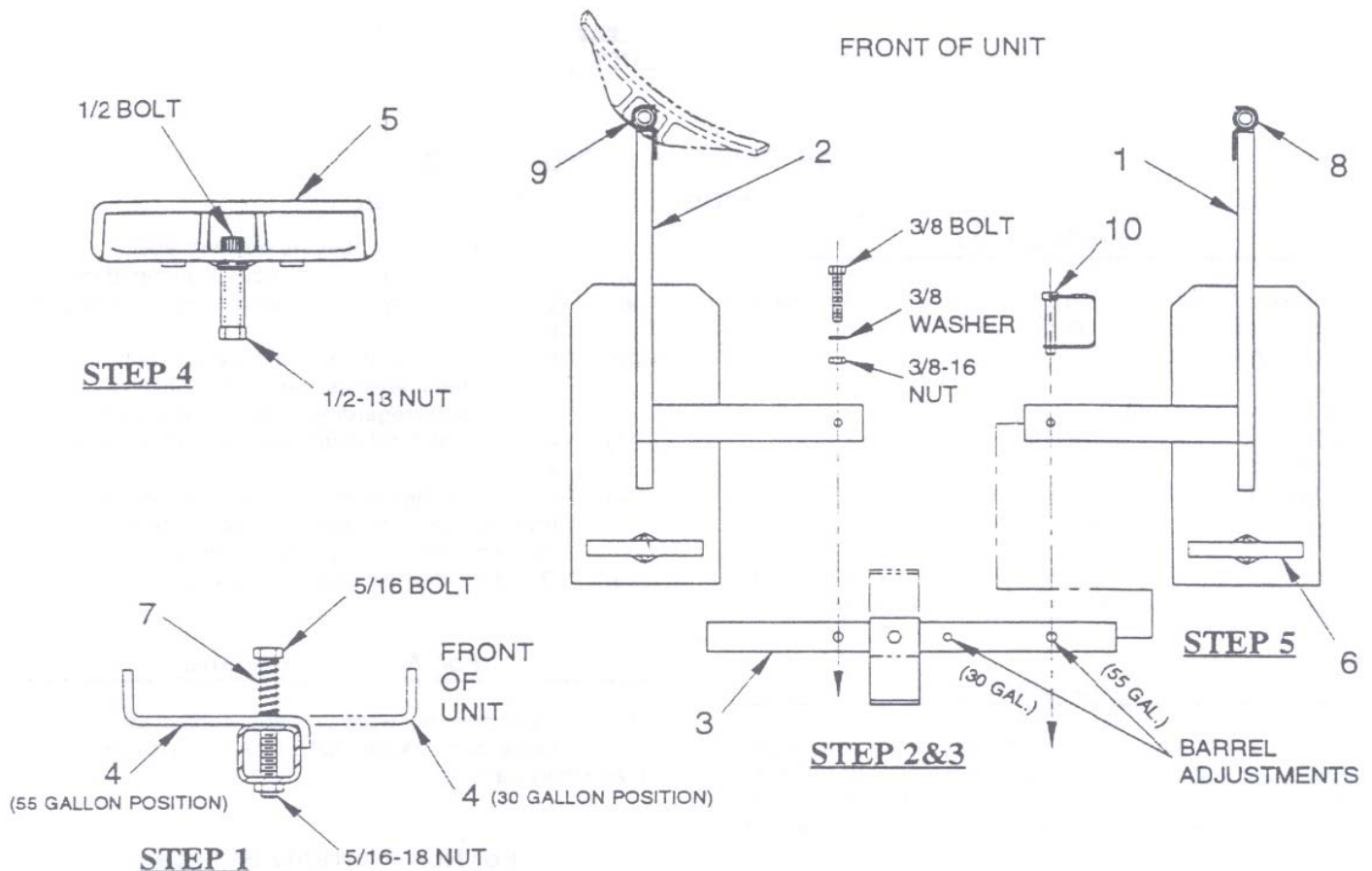

Figure 2