

**USER'S MANUAL
for
CENTRIFUGAL BLOWER**

9502	9505
9503	9505-50
9503-AU	9507
9503E	9508
9504	9512
9504-50	9512-AU
9504-50E	9512E

ALLEGRO[®]
I N D U S T R I E S



Read and understand all instructions before using this product. Open carton carefully and inspect product for damage caused by carrier. If any damage is found, report and submit claim to carrier.

TABLE OF CONTENTS

	<u>PAGE NUMBER</u>
INTRODUCTION/DESCRIPTION	3
SAFETY PRECAUTIONS	4-5
WARNINGS AND LIMITATIONS.....	6
OPERATION/USERS INSTRUCTIONS.....	7-12
BLOWER SPECIFICATIONS.....	13
MAINTENANCE	13-16
TROUBLESHOOTING	16-17
STORAGE.....	17
CONFINED SPACE APPLICATIONS	17-18
HAZARDOUS LOCATION INFORMATION	18
WARRANTY & RETURN POLICY	19-20

INTRODUCTION

This manual provides instructions for the use and maintenance of Allegro Industries CENTRIFUGAL BLOWERS. You must read and understand this manual and be trained in the proper use of the equipment before using it in a contaminated atmosphere.

There are many federal, state, and local codes and regulations governing sales, construction, installation and/or use of products for certain purposes, which may vary. Allegro cannot be responsible for how the products are used and installed. Before purchase and use, the buyer must review the product application, and be sure that the product installation and use will comply with those regulations.

For more information and assistance on Allegro Industries products, contact Allegro Technical Support toll-free at 1-800-622-3530 or e-mail at: techsvc@allegrosafety.com.

DESCRIPTION

Allegro Centrifugal Blowers are designed to offer high output CFM in easy-to-use portable configurations. They are available in outputs from 760 up to 3000 CFM of free air. The centrifugal blowers are available in a range of styles, sizes and power supplies. For Explosion-Proof Blowers, the receptacle should be installed by qualified personnel and is sold separately. Standard 115 VAC blowers include:

9512	Economy Blower
9512AU	Economy Blower*
9512E	Economy Blower*
9504	Standard Blower
9504-50	High Output Blower
9504-50E	High Output Blower*
9502	Heavy Duty Blower
9507	Two Speed Blower
9503	Heavy Duty Explosion-Proof Blower
9503AU	Heavy Duty Explosion-Proof Blower*
9503E	Heavy Duty Explosion-Proof Blower*

* *Models available in 220V/50 Hz*

As an alternative to electrically driven blowers, Allegro offers the following:

9508	Air Driven Blower
9505	Gasoline Powered Blower with a Subaru 5.7 HP Engine
9505-50	Gasoline Powered Blower with a Honda 4HP engine

SAFETY PRECAUTIONS

DO NOT operate blower until the operator completely comprehends the contents of this manual. The blower is a specialized type of powered equipment, designed for a specific job function and requires adequate and thorough instruction BEFORE it is operated. Each person must receive adequate professional instruction regarding proper operation. Read and understand this User Manual and the material supplied by the motor manufacturer. Refer to OSHA 29 CFR (1926 and 1910) for job safety and health rules and regulations covering construction.

DO NOT allow minors to operate the blower. Bystanders, children and animals should not be allowed to be near the area where a blower is in use.

DO NOT use undersized wire size on electrical power cable or extension cords if used. This will adversely limit the starting and load carrying capabilities of the motor. Always use minimum AWG wire sizes for motor branch circuits. Consult the National Electric Code Tables, Article 400, for specific information.

DO NOT operate the blower without the inlet and outlet screens properly secured and in place. Never replace the screens with other than factory replacements (OEM). The screen grid must comply with current OSHA regulations regarding protective enclosures to prevent personal injury to the operator(s). Ensure that the structural integrity of the screens will allow them to serve their protective function. Keep both screens free from obstructions and debris to allow maximum airflow.

DO NOT stand directly in front of and/or face the blower outlet. Personal injury can result from debris being thrown from the blower fan at relatively high velocity.

DO implement an operational safety program for this blower, to include but not limited to: instructional requirements for operation, applicable OSHA requirements, local laws and regulations, job site safety and blower maintenance. Operators must be fully instructed regarding the specifics of this safety program. [Ref. 29CFR 1926.21 (b) (2)].

DO ensure the blower is in its original factory configuration and has not been modified. Any modifications may result in potentially dangerous configurations that can lead to property damage and/or personal injury, as well as voiding the manufacturer's warranty.

DO ensure operator(s) are in adequate physical condition, mental health and not under the influence of any substance (drugs, alcohol, etc.) which might impair vision, dexterity or judgment. If you have any condition that might be aggravated by strenuous work, check with your doctor before operating the blower. Guard against the possibility of back related injuries. Always use proper lifting techniques when moving or carrying blower.

DO wear sturdy and snug fitting clothing. Never wear loose fitting jackets, scarves, neckties, jewelry, flared or cuffed pants or anything that could become caught on controls or moving parts. Wear long pants to protect your legs. To improve your grip and protect your hands, wear heavy duty, non-slip gloves. Good footing is vital when transporting the blower, wear sturdy steel-toed safety boots with non-slip soles. Sneakers or other similar type shoes do not provide adequate protection.

DO wear an approved safety hard hat. Noise, generated by the blower, may damage your hearing. Wear sound barriers (ear plugs or ear muffers). Continuous and regular operators should have their hearing checked regularly.

DO a visual inspection of the blower and check for damaged, worn, loose and/or broken parts. Ensure all safety devices are operable and information decals are readable. Check to see that the blower and all related accessories are in good mechanical condition before use.

DO verify the blower uses appropriate electrical cord and NEMA plug. Electrically driven blowers are designed to operate ONLY from a grounded 115 volt AC, 60Hz, single phase power source. Select models are available with 230 VAC or 220V/50Hz. All electrical wiring installations and connections must comply with all applicable NEC statutes and with all applicable local codes and practices.

DO consult current National Electric Code publications for specific information.

DO ground the blower motor securely. Ensure that the “grounding” wire and/or device are properly grounding the motor. Failure to properly ground the motor may cause an electrical shock and/or electrocution, resulting in personal injury or even death.

DO use a ground fault circuit interrupter (GFCI) (Allegro P/N: 9540). A ground fault circuit interrupter (GFCI) is a safety device that disconnects power from a circuit to a load when a potentially dangerous condition occurs. The GFCI acts like a fast-acting fuse or circuit breaker, sensing small imbalances in the circuit caused by current leakage, and shutting off electricity within 25mS (milliseconds). Use of a portable GFCI gives on-the-job protection from electrical shock hazards caused by ground faults in commercial, industrial and residential applications.

(For specific information, consult the NEC publications and OSHA publications for construction sites, marinas or for use around any area containing water.)

DO know where the controls are, how they operate, and how to stop the blower in an emergency.

DO verify the job site location classification. Certain job site locations may be classified as hazardous because of explosive concentrations of gas, vapor or dust in the atmosphere. The National Electric Code divides these locations into Classes and Groups according to the type of explosive agent. For specific information, consult the NEC, Section 500. Use Allegro Explosion-Proof Blowers for operation in an explosive or flammable atmosphere. The use of any other blower not designed for use in a Hazardous Location may result in personal injury or death.

DO place the blower on secure footing to prevent it from shifting while in use. Such movement can cause injury to the operator(s) or damage to the blower itself.

DO ensure blower is operated in a horizontal position to meet the enclosure definition. The blower is designed for operation in job site areas that are reasonably dry, clean and provide for a continuous, dynamic source of air for cooling the motor. Any questions about operating environments, contact the Allegro Technical Support at 1-800-622-3530, or e-mail at techsvc@allegrosafety.com, before using the blower.

WARNINGS AND LIMITATIONS

Manufacturing tolerances and specific operating parameters will affect the overall flow rate(s) for each particular blower. Actual flow rate will decrease when the total length of the ducting is increased more than 15 feet (7.6m). Actual flow rates may change if blower is used with ducts manufactured and/or supplied by other sources.

CAUTION!

The final working procedure for any job application involving the use of the blower must be individually determined after careful analysis of all factors and/or conditions present. The nearest OSHA office is a valuable source for applicable information regarding the operation of the blower.

CAUTION!

Before using the blower, check all applicable federal, state, industry and local regulations regarding the use of flame resistant and/or self-extinguishing duct materials for the intended job applications. It is the responsibility of the owner(s) and/or operator(s) to determine that the duct material in use for the job application meets all applicable fire code and OSHA requirements.

DANGER!

Never enter a manhole or confined work area until it has been determined to be safe for entry, tested with appropriate gas detection equipment and ventilated for a minimum of five (5) minutes with the blower at maximum speed.

DANGER!

Always stop the motor and disconnect the power source to prevent accidental starting and/or the possibility of receiving an electrical shock.

OPERATION

Use of Duct:

1. Operate the blower upwind from the work location and with the air inlet facing into the relative wind to maximize air flow.
2. The Allegro flexible ducts are for use with Allegro blowers.
 - a. All are of the collapsible, reinforced design.
 - b. Each duct is supplied with a nylon strap to secure each end to the blower and/or a duct connector.
 - c. When using statically conductive ducting, the integrated grounding wire must be both properly:
 - i. Grounded to the blower chassis.
 - ii. Linked to any additional grounding wire or duct used.

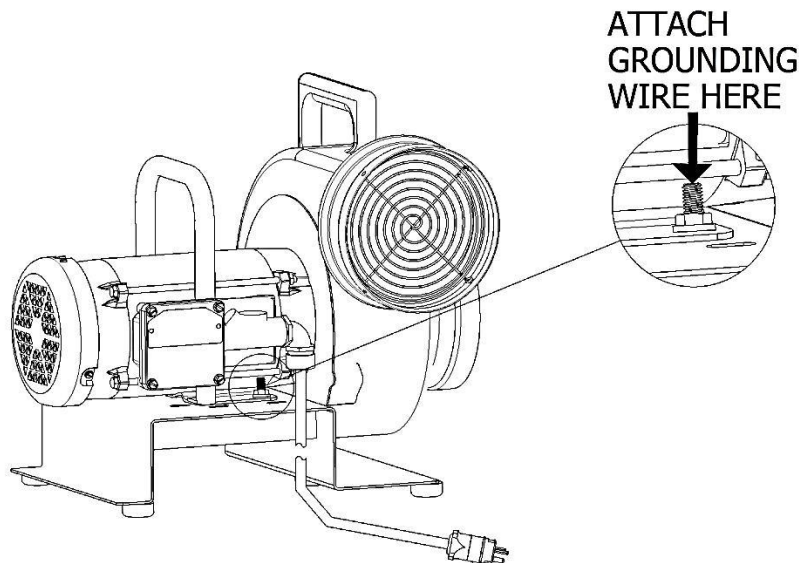

3. It is recommended the total length of duct does not exceed 100 feet.
4. To join two sections of duct, use a duct-to-duct connector.
5. Pull duct sleeve over the outlet port at least six (6) inches and secure the duct to the blower with the nylon clamping strap and tighten securely.
6. For exhaust (air blowing) operations, connect the duct to the blower outlet.
 - a. The duct can be one of two types:
 - i. Collapsible, non-reinforced.
 - ii. Collapsible, flexible, reinforced.
7. For extraction (air evacuation) operations, connect the duct to the blower inlet.
 - a. The duct must be of the reinforced type to prevent the vacuum force generated by the blower's suction from collapsing the duct.

DANGER!

Before using the blower, check all applicable federal, state, industry and local regulations regarding the use of flame resistant and/or self-extinguishing duct materials for the intended job applications. It is the responsibility of the owner(s) and/or operator(s) to determine that the duct material in use for the job application meets all applicable fire code and OSHA requirements.

OPERATION

Voltage and Power Selection:

1. The voltage, frequency and phase of the power supply must be consistent with the motor nameplate rating.
 - a. The motor will operate satisfactorily on voltages within 10% of the nameplate value or frequency within 5%. The combined variation must not exceed 10%.
2. The Allegro blowers are designed to operate from a grounded, 115 VAC 60Hz single phase power source.
 - a. Select models are available in a 230 VAC 60 Hz. Or 220 VAC 50 Hz single phase configuration.
 - b. It is crucial to the performance of the blower that the proper power source is selected.
3. Select blowers are supplied with a standard P5-15 plug or a twist-lock NEMA plug.
 - a. Do not change or alter the plug as this will affect the performance of the blower.
 - b. Operation from an inadequate power source or use of the incorrect electrical plug may result in property damage and/or personal injury.

WARNING!

GENERATOR USAGE

It is important to use the proper size generator when powering a blower. Using an undersized generator may cause damage to the blower motor. Please refer to the Specifications section for a minimum generator recommendation. Use of a generator at the minimum recommended output with additional devices can cause decreased output or blower stoppage.

CAUTION!

When choosing an extension cord, ensure that the cord is not an undersized wire. As a "Rule of Thumb", the diameter of cable for an extension cord should be larger than the diameter of the cord being plugged into it. Consult the NEC (National Electric Code) Tables for specific cord size information.

AIR DRIVEN BLOWER (P/N: 9508)

The motor for the Air Driven pump (P/N 9850) is a precision built rotary-type motor. The vanes for this motor will gradually wear. They will last 5,000 to 15,000 hours depending upon speed, operating pressure, and the precautions taken in maintaining the motor. The type of shaft seal used does not lend itself to operating pressures above 100 psi

(6.89 bars). The air motor requires a minimum of 30 CFM at 40 psi inlet pressure and volume to operate blower.

The starting torque is less than the running torque and could vary depending on the position at which the vanes stop in relation to the air intake port. The speed and torque can be regulated by using the pressure regulator or shut-off ball valve to obtain desired power.

WARNING!

To prevent explosive hazards, DO NOT run this air motor with combustible gases or in excess of the recommended speeds. Injury and/or property damage will result.

OPERATION:

1. Insure incoming air to the motor is clean and dry.
 - a. Excessive moisture in the air line can cause rust formation in the motor and might also cause ice to form on the muffler surface due to expansion of air.
 - b. The moisture problem can be corrected by installing an additional inline moisture separator.
2. The supply airline must be the same size or larger than the plumbing (intake port of the motor), for efficiency, output and control of speed.
 - a. Minimum ½" I.D.
 - b. Ensure the compressor is as close as possible to the blower, without affecting the quality of air near the inlet of the blower.
3. The lubricator should be adjusted and maintained to feed one drop of oil for every 50-75 CFM of air going through the air motor.
 - a. Lubrication is necessary for all internal moving parts and rust prevention.
 - b. For lubrication, use SAE #10 automotive engine oil.

Start up:

1. Connect air supply line to air motor.
2. Turn on air supply valve on motor.
3. Regulate the air pressure to 40 psi and 30 CFM.
 - a. Any variation of that will affect the performance of the air motor and pump.

Shut down:

1. Shut down air supply to air motor.
2. Slowly bleed off any excess air pressure and close valve.
3. Disconnect supply airline.
4. Blow dry clean air through motor at a low pressure to rid the motor of any damaging moisture.

Storage:

1. If motor is to be stored.
 - a. Disassemble plumbing from inlet port.
 - b. Add a few drops of oil to the inlet port.
 - c. Manually rotate shaft to circulate the oil.

GASOLINE POWERED BLOWER
9505 & 9505-50

Filling the Engine Crankcase with Oil

Tools required:

- Small clean funnel
- A clean shop rag
- Oil

1. Position the blower on level ground.
2. Wipe away any dust or dirt from the engine crankcase on the end opposite to the gasoline tank. Remove the filler plug.
3. Using the funnel, pour 2/3 qt. or 21 ounces (if required) of high-grade 30W motor oil into the engine crankcase. **DO NOT OVERFILL.**

Refer to the operation and maintenance instructions supplied by the engine manufacturer for specific information regarding proper oil type, weight, and engine service classification.

4. Reinstall the engine crankcase filler plug. Wipe off any excess oil spilled on engine.
5. Do not mix oil with the gasoline. The air filter element is the paper type and does not require oiling.

DANGER!

This blower uses a four-cycle gasoline engine with lubricating oil contained in its crankcase. Do not operate the engine unless proper oil level is maintained. Failure to operate the engine without the proper crankcase oil level will result in severe engine damage and the possibility of property damage and or personal injury.

If improperly filled, the engine may emit excessive smoke when operated or appear to be seized when attempting to start. To correct these situations, drain the excess oil and remove the engine spark plug to clear oil trapped above the piston.

FUELING CAUTIONS:

1. Gasoline is flammable. Use extreme caution when handling gasoline or mixing fuel.
2. Always use UL® approved containers for the fuel storage and/or transportation of fuel.
3. Do not smoke, operate spark inducing equipment nearby or bring any fire or flame near the fuel.
4. Always shut off the engine and allow it to cool before refueling.
5. Never remove the gasoline tank filler cap while the engine is running.
6. Never operate an engine without a gasoline tank filler cap.
7. Select bare ground for refueling and move at least 10 feet from the fueling spot before starting the engine.
8. Wipe off any spilled fuel before starting the engine and check for leakage.
9. If a fuel or oil leak is found, do not start or run the engine until the leak is fixed and the spillage has been wiped away.

10. Take care not to get fuel or oil on your clothing. If this happens, change your clothing immediately.
11. Before operating the blower, refer to the Maintenance Section of this manual for more detailed information.

Filling the Engine Gasoline Tank

1. Tools required:
 - A small clean funnel
 - A rag
 - Unleaded gasoline- Octane of 86 or Higher.
2. Carefully clean the filler cap and surrounding area to insure that no dirt or debris falls into the gasoline tank.
3. Fill the gasoline tank. Use fresh, clean, unleaded gasoline.
 - a. Do not fill the gasoline tank to the point of overflowing. (Allow approximately ½ inch of tank space for fuel expansion.)
 - b. Refer to the operating and maintenance instructions provided by the engine manufacturer for specific information regarding fuel recommendations and related procedures.
4. Use of a properly blended gasoline for operation during the intended season will result in easier engine starting. Do not use gasoline left over from the previous season of operation.

DANGER!

Do not smoke near the gasoline tank. Do not fill the gasoline tank with the engine running or if it is hot. Allow ample time (5 minutes minimum) between each refueling for the engine to cool.

WARNING!

Position the 9505-50 Gas Blower so the inlet ducting is “upwind” of the gas blower exhaust. The opening of the ducting should be positioned so the air inlet is facing into the relative wind.

Starting the Engine

1. Place the blower on level ground on the desired work location.
 - a. Ensure motor is filled with the recommended oil, and oil level is maintained.
 - b. The location should be relatively flat to prevent vibration from allowing the blower to move.
2. Open the fuel feed valve.
3. When starting a cold engine, move the choke lever to the CLOSED position or as far as possible in the direction indicated by the arrow on the lever.
 - a. A warm engine may not require choking.

4. Pull the throttle control lever to the RUN position, or 2/3 of the way to the FAST position.
5. Turn the engine switch to the ON position.
6. Position the recoil starter handle until resistance is felt.
 - a. Pull briskly, and return starter grip gently.
 - b. If the engine fires but does not start, do not continue to choke the engine.
 - c. Repeat until the engine starts.
 - d. When the engine starts, open the control gradually.
7. Select an adequate clearance for the operator's arm and/or hand when starting the engine.
 - a. A small or confined work area for starting the engine can result in personal injury.
8. Operate the blower at proper, governed engine RPM or at the speed that delivers the required air flow rate.
9. To stop the blower, move the throttle control lever to the STOP position or by grounding the spark plug with the lever provided (if so equipped).

DANGER!

Operation of the blower on any given surface material and/or configuration may generate random movements, rocking and/or creeping. This random movement and/or creeping is a result of the inherent operating characteristics of the gasoline engine and cannot be readily defined and/or anticipated.
Such movement and/or creeping can result in property damage, personal injury or even death.

CENTRIFUGAL BLOWER SPECIFICATIONS

ELECTRIC MODELS:

PART No	HP	AMP	VOLTAGE	WEIGHT	Flow Rate (Free Air)	MINIMUM GENERATOR SUGGESTION
9504	1/3	3.6	115V, 60Hz	38 lbs.	1066	2KV *
9502	1 ½	17.2	115V, 60Hz	61 lbs.	1700	6KV *
		8.8-8.6	208-230V, 60 Hz			
9504-50	3/4	10.8	115V, 60Hz	45 lbs.	1570	2KV *
		5.3-5.4	208-230V, 60Hz			
9504-50E	3/4	11.8	110V, 50 Hz	45 lbs.	1300	2 KV*
		5.9	220V, 50 Hz			
9512	1/3	3.6	115V, 60Hz	41 lbs.	1066	2KV *
9512AU/ 9512E	1/2	3.6	220V, 50 Hz	41 lbs.	784	2KV *
9503	3/4	10.6	115V, 60 Hz	76 lbs.	1570	2KV *
		5.3	230V, 60Hz			
9503AU/ 9503E	3/4	9.6	110V, 50 Hz	76 lbs.	1300	2KV *
		4.8	220V, 50 Hz			
9507	1/3	6.8	115V, 60 Hz	64 lbs.	760- Low speed	2KV *
	3/4	9.6			1850- Hi speed	

*This is the minimum tested wattage per each specific motor, by its horsepower. If more than one unit is being powered, the generator output must be increased accordingly.

NON-ELECTRIC MODELS:

Part #	Flow Rate (Free Air)	HP	Drive Source	Power Requirement	Weight
9508	1800	¾ (Approx.)	Compressed Air	30 cfm @ 40 psi	43 lbs.
9505	2000-3000	5.7	Gasoline	87 Octane	54 lbs.
9505-50	2000-3000	4	Gasoline	87 Octane	63 lbs.

MAINTENANCE

GENERAL MAINTENANCE AND REPAIR

1. Use only genuine, approved, replacement parts for maintenance and repair. Use of parts manufactured by other manufacturers can result in property damage and/or personal injury.
2. Always properly maintain the blower. Frequently check all fasteners and individual parts. Built-in safety features are effective only if they are maintained in good working condition.

3. Keep the blower clean and properly serviced. Heavy accumulations of dust and dirt will result in overheating and premature failure of the blower motor. Clean the motor surfaces and all ventilation openings periodically.
4. Always stop the motor and disconnect the power source to prevent the accidental starting and/or the possibility of receiving an electrical shock before working on the blower.
5. Do not energize the electric motor with the shaft key exposed on the open shaft. Personal injury can result from being struck by a shaft key thrown from the motor shaft.

DANGER!

Always stop the motor and disconnect the power source to prevent the accidental starting and/or the possibility of receiving an electrical shock. Do not attempt any maintenance or repair work not described in this User's Manual

BLOWER HOUSING:

1. Do not operate the blower with excessive dirt or other debris inside the blower housing assembly.
 - a. This will affect air flow delivery performance.
 - b. Clean periodically.
2. Disassemble the blower housing and clean off excessive dirt or other debris.
 - a. Tools required are as follows:

i	Two 7/16 inch wrenches.
ii	One small flat bladed screwdriver
iii	One Phillips head screwdriver #2

3. Always check the structural integrity of the inlet and outlet screens.
 - a. Do not re-install a damaged and/or defective screen.
 - b. Do not operate the blower without the inlet and outlet screens properly secured and in place.
4. The blower wheel is factory balanced at the time of manufacture and should not require rebalancing under normal usage.
 - a. Periodically apply a light coat of dry film lubricant to prevent rust formation.

DANGER!

Do not paint or alter the blower fan wheel configuration in any manner. This will result in an unbalanced fan wheel, which may cause property and/or personal injury. Proper balance is essential to maximize air flow delivery.

ELECTRIC MOTOR:

1. The electric motor is capable of operating for many years with minimal maintenance.
2. Before attempting to service the motor, disconnect the blower from the power supply.
3. Clean the motor surface and ventilation openings periodically, preferably with a vacuum cleaner. Heavy accumulation of dirt and lint will lead to overheating and premature failure of the motor.
4. The electric motor is equipped with ball bearings, and under normal service and ambient temperatures, should not require re-lubrication for 9-10 years. If you feel that the motor requires re-lubrication, contact the local service representative of the motor manufacturer for specific information.

AIR DRIVEN BLOWER MAINTENANCE:

Flushing Instructions (P/N 9508):

1. If air motor is sluggish or inefficient, flush with Allegro Flushing Liquid (P/N 9700-11).
2. Perform this procedure in a well-ventilated area.
3. Disconnect inlet plumbing from inlet port and muffler assembly.
4. Add 10-15 squirts of solvent into the inlet port.
5. Rotate the shaft by turning blower wheel by hand in both directions for a few minutes.
6. Reassemble inlet plumbing and reconnect the inlet air supply line and slowly apply air pressure.
7. Flushing liquid should slowly exit the exhaust port, let run for 10 minutes.
8. Reassemble exhaust assembly.
9. Re-lubricate the motor with a squirt of oil in the chamber.

WARNING!

Wear solvent resistant gloves and eye protection while performing the flushing procedure. Keep face away from exhaust port. Do not flush unit with KEROSENE or other COMBUSTIBLE liquids. Personal injury and/or property damage will result.

Carbon Vanes:

The air motor chamber might need to be opened up and inspected, if the vanes need replacing or foreign materials are present in motor chamber.

1. An experienced mechanic may remove the end plate opposite the drive shaft end.
 - a. Do not pry with a screwdriver, this will dent the surface of the plate and body causing air leaks.
 - b. A pulling tool should be used to remove the end plate while maintaining the position of the shaft.
2. New vanes should have the edge with the corners cut on an angle or the notched edge towards the bottom of the vane slot.
3. Proper clearance must be set from the rotor to the chamber.

GASOLINE POWERED BLOWER MAINTENANCE

Consult the operating and maintenance instructions provided by the engine manufacturer for specific service and maintenance information regarding:

- Oil
- Carburetor adjustment.
- Muffler or emissions related components.
- Spark plug replacement
- Air filter replacement.
- Short and long term storage

TROUBLESHOOTING

ELECTRIC MOTOR:

TROUBLE	CAUSE
Motor Fails to Start or Stalls	Blown Fuses
	Improper current supply
	Improper line connections
	Motor may be overloaded
	Defective capacitor
Motor runs and then dies	Power failure
Motor does not come up to speed	Open primary circuit
Motor overheats while running under load	Overload
	Dirt build-up, insufficient ventilation.
	Faulty connection
	Improper voltage
Scraping noise	Fan striking housing

AIR DRIVEN UNIT:

TROUBLE	CAUSE
Low torque or speed	Dirt or foreign material
	Jammed Rotor
	Insufficient air pressure
	Poor lubrication.
Low Speed	Supply airline to the motor could be too small
	Exhaust is restricted.
	Excess moisture in air supply
	Muffler too close to motor
Motor runs hot	Poor lubrication.
	Misalignment
Motor runs well, then slows down	Poor lubrication.
	Restricted muffler
Motor will not turn at all	Worn Vanes
	Dirt or foreign material
	Jammed Rotor
	Poor lubrication.
	Misalignment

GAS BLOWER:

TROUBLE	CAUSE
Engine will not start	Check throttle position
	Fuel valve OFF.
	Choke OPEN.
	Out of fuel.
	Spark plugs faulty, fouled, or improperly gapped.
	Spark plugs wet with fuel (Flooded engine).
	Spark Plug cable loose
Engine overheats	Poor Lubrication
Engine lacks power	Air filter elements(s) clogged.
Engine lacks power or will not start	Bad fuel: engine stored without treating or draining gasoline,
	Fuel filter clogged, carburetor malfunction, ignition malfunction, valves stuck, etc.

Contact Allegro Technical Support at 800-622-3530 or email techsvc@allegrosafety.com

STORAGE

The proper procedure for long-term storage of the blower will protect it against the effects of corrosion and damage. If the blower is not to be operated for a period of 30 days or more, proceed to store as follows:

1. Clean all accumulated dirt and grease from the blower using an appropriate cleaner.
2. Follow the electric motor manufacturer's instructions regarding long term storage of the motor.
3. Check parts for wear or damage. Make the necessary repairs.
4. Apply a light coat of dry film lubricant to the blower wheel and shaft to prevent rust formation.
5. Store the blower indoors. If the blower must be stored outdoors, protect it from the elements with a suitable enclosure or storage location.

CONFINED SPACE APPLICATIONS

WARNING! **FOR GASOLINE POWERED BLOWERS**

Ensure the blower intake is away from exhaust extension and/or any carbon monoxide fumes (when gasoline engine is operated or any other source of harmful fumes or gases).

ATTENTION!

Refer to local and federal OSHA Confined Space Laws and Regulations.

CAUTION!

The final working procedure for any job application involving the use of the blower must be individually determined after careful analysis of all factors and/or conditions present. The nearest OSHA office is a valuable source for applicable information regarding the field use of the blower.

HAZARDOUS LOCATION INFORMATION

- All Explosion Proof Blowers must be used with the Hazardous Location Plug and Socket
- Must use only Statically Conductive ducting with Explosion Proof Blowers.
- Verify your job site location classification.
- The Allegro Explosion Proof Blowers are designed to be used in the following hazardous locations:

Blower	9 5 0 3	
Class	I	II
Division	1 & 2	1 & 2
Group	D	F & G

- Ensure the blower design meets the hazardous class and group classifications of job site.
- The National Electric Code divides these locations into Classes and Groups according to the type of explosive gas/agent, which may be present.
- For specific information on Hazardous Location requirements, consult the National Electric Code, Section 500 through 517, or a qualified electrician.
- The Hazardous Location plug and receptacle must be used and properly wired using a conduit system to the power source.

WARNING!

Hazardous location receptacle, or socket, must be installed by qualified personnel.

CAUTION!

Hazardous location equipment may be required in any area where the presence of flammable gases, vapors or finely pulverized dusts in the atmosphere is sufficient to create a threat of explosion or fire. It may also be required where easily ignitable fibers or flyings are present.

**ALLEGRO INDUSTRIES
LIMITED WARRANTY AND WARRANTY SERVICE AND RETURN POLICY**

Express Warranty

The warranty obligations of Allegro Industries ("Allegro") are limited to the terms set forth below:

All products, equipment and parts (collectively "Product" or "Products") sold by Allegro, either directly to its customers, or indirectly from its suppliers or distributors to their customers, are warranted, to the original end-user purchaser who/that receives the original, unaltered Product ("Purchaser"), to be free from defects in workmanship and materials under normal use for one (1) year from the date of sale to the Purchaser, when installed properly and used normally and in accordance with written operation instructions, if any ("Limited Warranty") ("Warranty Period"). No other express or implied warranty is given, and no affirmation of Allegro, by words or action, will constitute a warranty.

This Limited Warranty is conditioned upon proper use of the Product by Purchaser and applies only to Products manufactured by or for Allegro that can be identified by the Allegro trademark, trade name or logo affixed to them. This Limited Warranty does not apply to or cover: (a) defects or damage caused by or resulting from external causes including, but not limited to, accident, carrier handling, improper packaging in shipment; abuse, misuse, neglect, unusual physical stress, cosmetic damage, flood, fire, earthquake or other natural disasters; (b) normal wear and tear; (c) any modification of any part of the Product; (d) damage caused by using the Product outside the permitted or intended uses described by Allegro or written instructions; (e) malfunctions resulting from the use of the Product in conjunction with accessories, products or ancillary/peripheral equipment not furnished or approved by Allegro; (f) defects or damage caused by improper testing, operation, maintenance, installation or adjustment; or (g) defects or damage caused by installation and/or service performed by anyone who is not authorized by Allegro.

Each Purchaser agrees and acknowledges that the use, installation and/or operation of the Products shall be at Purchaser's own risk and may result in severe injury, death and/or damage to persons or real and/or personal property.

No Allegro supplier, distributor, officer, agent or employee is authorized to make any modification, extension, change or amendment to this Limited Warranty without the express prior written consent and authorization by the President of Allegro.

Allegro reserves the right to make improvements or changes to its Products at any time, without incurring any obligation to Purchasers, suppliers, distributors or customers who/that previously purchased Products directly or indirectly from Allegro.

EXCEPT AS SET FORTH IN THE EXPRESS WARRANTY CONTAINED HEREIN, PURCHASER TAKES THE PRODUCT "AS IS." THERE ARE NO EXPRESS OR IMPLIED WARRANTIES OR CONDITIONS BEYOND THOSE STATED IN THIS LIMITED WARRANTY STATEMENT. ALLEGRO DISCLAIMS ALL OTHER WARRANTIES AND CONDITIONS, EXPRESS OR IMPLIED, INCLUDING, BUT NOT LIMITED TO, THE WARRANTY OF MERCHANTABILITY OF THE PRODUCTS AND THEIR FITNESS FOR ANY PARTICULAR PURPOSE.

NOTHING CONTAINED IN ANY WRITTEN INSTRUCTIONS OR WRITTEN INSTRUCTION OR OPERATION MANUAL OR CATALOG SHALL BE CONSTRUED TO CREATE A WARRANTY OF ANY KIND WHATSOEVER WITH RESPECT TO THE PRODUCT.

IN ADDITION, TO THE FULLEST EXTENT PERMISSIBLE BY APPLICABLE LAW, ALLEGRO SHALL NOT BE LIABLE FOR ANY INJURY OR DAMAGE TO PERSONS OR PROPERTY OF ANY KIND, OR FROM ANY LOSS OF TIME, INCONVENIENCE, OR LOSS OF USE, INCLUDING ANY CONSEQUENTIAL, INCIDENTAL OR SPECIAL DAMAGES ARISING DIRECTLY OR INDIRECTLY OUT OF OR IN CONNECTION WITH THE USE, INSTALLATION AND/OR PERFORMANCE OF THE PRODUCT OR PRODUCTS, WHETHER SUFFERED BY SUPPLIER, DISTRIBUTOR, CUSTOMER, PURCHASER OR ANY OTHER PARTY, AND REGARDLESS OF THE LEGAL THEORY UPON WHICH THE CLAIM IS BASED, EVEN IF ALLEGRO HAS BEEN ADVISED OF THE POSSIBILITY OF SUCH DAMAGES. WITHOUT OTHERWISE LIMITING THE FOREGOING, IN NO EVENT SHALL RECOVERY OF ANY KIND AGAINST ALLEGRO BE GREATER IN AMOUNT THAN THE PURCHASE PRICE OF THE PRODUCT. THIS WARRANTY GIVES YOU LIMITED SPECIFIC LEGAL RIGHTS.

Warranty Service and Return Policy during Warranty Period

The following requirements must be followed before returning any Product or Products to Allegro:

1. All Purchasers must obtain a Return Merchandise Authorization Number ("RMA#") before returning any Product to Allegro. Allegro will refuse to accept any Product returned that does not have the RMA# clearly marked on the outside of the package or box. The Purchaser may obtain this RMA# by telephoning Allegro's Customer Service number at (800) 622-3530, or by requesting it in writing by mailing the written request to Allegro Industries, 1360 Shiloh Church Road, Piedmont, South Carolina 29673, or by faxing the written request to Allegro Industries at (800) 362-7231.
2. Upon Allegro's issuance of RMA # to a Purchaser, the Purchaser must decontaminate and clean the Product to remove any hazardous materials which may have settled on the Product during use. Allegro reserves its rights to refuse, and will refuse, to accept any Product suspected of being contaminated and/or containing any dangerous chemical(s) or material(s), and will return that Product or those Products to the Purchaser, freight collect.
3. All Purchasers must return the Product or Products to Allegro freight prepaid, with the RMA# clearly marked on the outside of the box or package. Each Product to be returned should be packaged in its original Product packaging materials or equivalent, and be well padded, to prevent damage when in transit, and should be adequately insured by Purchaser. All Purchasers must bear the risk of loss of the Product during transit from Purchaser to Allegro. Inside the Product's package, please enclose your name, address, and telephone number, a description of the problem and a model and/or serial number for each Product returned.

Upon Allegro's receipt of a returned Product from a Purchaser that meets the above requirements, Allegro will determine in its sole discretion whether the Product is defective. If Allegro determines that the Product is not defective and/or does not meet the terms of this Limited Warranty, Allegro will return the Product to the Purchaser freight collect. If Allegro determines that the Product is defective, Allegro will determine in its sole discretion whether to repair or replace the defective Product covered by this Limited Warranty.

Each Purchaser's sole and exclusive remedy for defects in Products covered by this Limited Warranty is limited to Allegro's correction of the defect by repair or replacement.

4. Authorized returns of saleable merchandise, other than shipments made in error by Allegro, will be subject to a 20% restocking charge.

Warranty Terms

This Limited Warranty represents the complete and exclusive agreement covering this subject matter between Allegro and Purchaser and supersedes any prior agreements and/or communications regarding the subject matter hereof. The terms of this Limited Warranty shall be governed and construed in accordance with the laws of the State of California, without regard to any conflict of law principle that would result in the laws of any other jurisdiction governing this Limited Warranty. Any action or proceeding arising out of this Limited Warranty shall be litigated in the California Superior Court located in Orange County, California. Each Purchaser purchasing any Product from Allegro, directly or indirectly, shall be deemed to consent and submit to the jurisdiction of the state court located in Orange County, California. If any term or provision contained in this Limited Warranty is determined to be unenforceable in any respect, the enforceability of the term or provision in any other respect and of the remaining terms and provisions of this Limited Warranty shall not be impaired. This Limited Warranty shall not extend to anyone other than the original Purchaser of the Product(s) and shall be Purchaser's exclusive remedy. Each Purchaser acknowledges that this Limited Warranty will always be construed to be limited by its terms to the greatest extent as the law permits.

UM003 Rev K
04/24/2015
DCN D#0783