

INSTALLATION INSTRUCTIONS AND PARTS IDENTIFICATION
TUBULAR GAS FIRED DIRECT SPARK PROPELLER UNIT HEATERS
– FOR COMMERCIAL, INDUSTRIAL AND RESIDENTIAL INSTALLATIONS –

ATTENTION: READ THIS MANUAL AND ALL LABELS ATTACHED TO THE UNIT CAREFULLY BEFORE ATTEMPTING TO INSTALL, OPERATE OR SERVICE THESE UNITS! CHECK UNIT DATA PLATE FOR TYPE OF GAS AND ELECTRICAL SPECIFICATIONS AND MAKE CERTAIN THAT THESE AGREE WITH THOSE AT THE POINT OF INSTALLATION. RECORD THE UNIT MODEL AND SERIAL No.(s) IN THE SPACE PROVIDED. RETAIN FOR FUTURE REFERENCE.

Unit No. _____ Serial No. _____

FOR YOUR SAFETY

Do not store or use gasoline or other flammable vapors and liquids in the vicinity of this or any other appliance.



**FOR YOUR SAFETY
WHAT TO DO IF YOU SMELL GAS**

**Do not try to light any appliance.
Do not touch any electrical switch; do not use any phone in your building.
Immediately call your gas supplier from a neighbor's phone. Follow the gas supplier's instructions.
If you cannot reach your gas supplier, call your fire department.**



**ENERGY
PERFORMANCE
VERIFIED
RENDEMENT
ENERGETIQUE
VERIFIE**

▲ WARNING Improper installation, adjustment, alteration, service, or maintenance can cause property damage, injury, or death. Read the installation, operating, and maintenance instruction thoroughly before installing or servicing this equipment.

APPROVED FOR USE IN CALIFORNIA

▲ WARNING Install, operate, and maintain unit in accordance with the manufacturer's instructions to avoid exposure to fuel substances, or substances from incomplete combustion, which can cause death or serious illness. The state of California has determined that these substances may cause cancer, birth defects, or other reproductive harm.

INSTALLER'S RESPONSIBILITY

Installer Please Note: This equipment has been test fired and inspected. It has been shipped free from defects from our factory. However, shipment and installation problems such as loose wires, leaks, or loose fasteners may occur. **It is the installer's responsibility to inspect and correct any problem that may be found.**

RECEIVING INSTRUCTIONS

Inspect shipment immediately when received to determine if any damage has occurred to the unit during shipment. After the unit has been uncrated, check for any visible damage to the unit. If any damage is found, the consignee should sign the bill of lading indicating such damage and immediately file claim for damage with the transportation company.



MESTEK, INC.

260 NORTH ELM ST., WESTFIELD, MA 01085

TEL: (413) 568-9571 FAX: (413) 562-8437

www.mestek.com



TABLE OF CONTENTS

SPECIFICATIONS	OPERATION	28
Basic Description	GAS INPUT RATE	29
Performance & Specification Data	MAINTENANCE	
GENERAL SAFETY INFORMATION	Servicing & Cleaning	30
Installation Codes	TROUBLESHOOTING GUIDE	31-35
Special Precautions	IDENTIFICATION OF PARTS	36-37
INSTALLATION	WARRANTY	38
Locating Units	UNIT NUMBER DESCRIPTION	39
Combustion Air	INSPECTION SHEET.....	40
Proper Clearances		
Suspension of Units		
Gas Supply Piping		
ELECTRICAL CONNECTIONS		
VENTING		
General		
Standard Combustion		
Separated Combustion		

NOTICE: It is the equipment owners responsibility to provide any scaffolding or other apparatus required to perform emergency service or annual/periodic maintenance to this equipment.

DESCRIPTION

The Tubular Gas Fired Unit Heater is a factory assembled, power vented, low static pressure type propeller fan unit heater designed to be suspended within the space to be heated. THESE HEATERS ARE NOT TO BE CONNECTED TO DUCTWORK. These Tubular Unit Heaters are design certified under ANSI

Z83.8 for Industrial/Commercial use and IAS .10.96 U.S. (2nd ed.) "Unit Heaters for Residential Installation". The designs are certified by ETL as providing a minimum of 82% thermal efficiency, and approved for use in California. **Do not alter these units in any way.** If you have any questions after reading this manual, contact the manufacturer.

Figure 1 - Tubular 30 thru 120 Propeller Unit Heaters

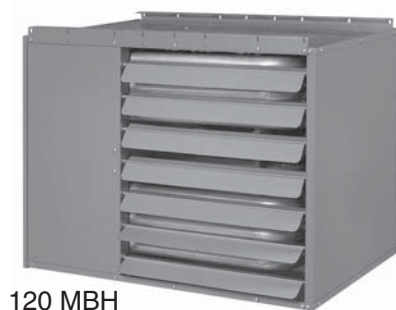

See Identification of Parts, Figures 22 through 28.

The following terms are used throughout this manual, in addition to the ETL requirements to bring attention to the presence of potential hazards, or to important information concerning the product:

▲ DANGER Indicates an imminently hazardous situation which, if not avoided, will result in death, serious injury, or substantial property damage.

▲ WARNING Indicates an imminently hazardous situation which, if not avoided, could result in death, serious injury, or substantial property damage.

▲ CAUTION Indicates an imminently hazardous situation which, if not avoided, may result in minor injury or property damage.

NOTICE: Used to notify of special instructions on installation, operation, or maintenance which are important to equipment but not related to personal injury.

GENERAL SAFETY INFORMATION

▲ WARNING Failure to comply with the general safety information may result in extensive property damage, severe personal injury, or death.

▲ WARNING This product must be installed by a licensed plumber or gas fitter when installed within the Commonwealth of Massachusetts.

Installation must be made in accordance with local codes, or in absence of local codes, with the latest edition of ANSI Standard Z223.1 (N.F.P.A. No. 54) National Fuel Gas Code. All of the ANSI and NFPA Standards referred to in these installation instructions are those that were applicable at the time the design of this appliance was certified. The ANSI Standards are available from CSA Information Services 1-800-463-6727. The NFPA Standards are available from the National Fire Protection Association, Batterymarch Park, Quincy, MA 02269.

If installed in Canada, the installation must conform with local building codes, or in the absence of local building codes, with CSA-B149.1 "Installation Codes for Natural Gas Burning Appliances and Equipment" or CSA-B149.2 "Installation Codes for Propane Gas Burning Appliances and Equipment." These unit heaters have been designed and certified to comply with CSA 2.6.

▲ WARNING Do not alter the unit heater in any way or damage to the unit and/or severe personal injury or death may occur!

▲ WARNING Disconnect all power and gas supplies before installing or servicing the heater. If the power disconnect is out of sight, lock it in the open position and tag it to prevent unexpected application of power. Failure to do so could result in fatal electric shock, or severe personal injury.

▲ CAUTION Ensure that all power sources conform to the requirements of the unit heater, or damage to the unit will result!

Follow installation instructions CAREFULLY to avoid creating unsafe conditions. All wiring should be done and checked by a qualified electrician, using copper wire only. All gas connections should be made and leak-tested by a suitably qualified individual, per instructions in this manual. Also follow procedures listed on "Gas Equipment Start-Up Sheet" located in this manual.

Use only the fuel for which the heater is designed (see rating plate). Using LP gas in a heater that requires natural gas, or vice versa, will create risk of gas leaks, carbon monoxide poisoning, and explosion.

▲ WARNING Conversion to a fuel other than that listed on the rating plate is permitted only with a factory supplied, ETL approved conversion kit.

Make certain that the power source conforms to the electrical requirements of the heater.

▲ WARNING Do not depend upon a thermostat or other switch as sole means of disconnecting power when installing or servicing heater. Always disconnect power at main circuit breaker as described above. Failure to do so could result in fatal electric shock.

Special attention must be given to any grounding information pertaining to this heater. To prevent the risk of electrocution, the heater must be securely and adequately grounded. This should be accomplished by connecting a ground conductor between the service panel and the heater. To ensure a proper ground, the grounding means must be tested by a qualified electrician.

Do not insert fingers or foreign objects into heater or its air moving device. Do not block or tamper with the heater in any manner while in operation, or just after it has been turned off, as some parts maybe hot enough to cause injury.

This heater is intended for general heating applications ONLY. It must NOT be used in potentially dangerous locations such as flammable, explosive, chemical-laden, or wet atmospheres.

Do not attach ductwork to this product or use it as a makeup air heater. Such usage voids the warranty and will create unsafe operation.

In cases in which property damage may result from malfunction of the heater, a back-up system or temperature sensitive alarm should be used.

Should overheating occur, or the gas supply fail to shut off, shut off the manual gas valve to the appliance before shutting off the electrical supply.

▲ CAUTION The open end of piping systems being purged shall not discharge into areas where there are sources of ignition or into confined spaces UNLESS precautions are taken as follows: (1) by ventilation of the space, (2) control of the purging rate, (3) elimination of all hazardous conditions. All precautions must be taken to perform this operation in a safe manner!

Unless otherwise specified, the following conversions may be used for calculating SI unit measurements:

1 foot = 0.305 m	1000 BTU/cu. ft. = 37.5 MJ/m ³
1 inch = 25.4 mm	1000 BTU per hour = 0.293 kW
1 gallon = 3.785 L	1 inch water column = 0.249 kPa
1 pound = 0.453 kg	liter/second = CFM x 0.472
1 psig = 6.894 kPa	meters/second = FPM ÷ 196.8
1 cubic foot = 0.028m ³	

Table 1 - Performance and Dimensional Data - Tubular 30 thru 120 Propeller Unit Heater

Unit Size	30	45	60	75	90	105	120
PERFORMANCE DATA†							
Input - BTU/Hr.	30,000	45,000	60,000	75,000	90,000	105,000	120,000
(kW)	(8.8)	(13.2)	(17.6)	(22.0)	(26.4)	(30.8)	(35.2)
Output - BTU/Hr.	24,900	37,350	49,800	61,500	73,800	86,100	98,400
(kW)	(7.2)	(10.9)	(14.5)	(18.0)	(21.6)	(25.2)	(28.8)
Thermal Efficiency (%)	83	83	83	82	82	82	82
Free Air Delivery - CFM	370	550	740	920	1,100	1,300	1,475
(cu. m/s)	(.175)	(.260)	(.349)	(.434)	(.519)	(.614)	(.696)
Air Temperature Rise - °F	60	60	60	60	60	60	60
(°C)	(15)	(15)	(15)	(15)	(15)	(15)	(15)
Full Load Amps at 120V	3.0	3.0	4.1	4.1	6.4	6.4	6.4
Maximum Circuit Ampacity	3.5	3.5	4.8	4.8	7.5	7.5	7.5
MOTOR DATA:							
Motor HP	1/20	1/20	1/12	1/12	1/10	1/10	1/10
Motor (kW)	(0.04)	(0.04)	(0.06)	(0.06)	(0.075)	(0.075)	(0.075)
Motor Type ODP ††	SP	SP	SP	SP	SP	SP	SP
RPM	1650	1650	1050	1050	1050	1050	1050
Motor Amps @ 115V	1.9	1.9	2.6	2.6	4.2	4.2	4.2
DIMENSIONAL DATA - inches (mm)							
"A" Jacket Height	12-3/8 (314)	12-3/8 (314)	15-7/8 (403)	15-7/8 (403)	22-5/8 (574)	22-5/8 (574)	22-5/8 (574)
"B" Overall Height	13-1/4 (337)	13-1/4 (337)	16-13/16 (427)	16-13/16 (427)	23-9/16 (598)	23-9/16 (598)	23-9/16 (598)
"C" Overall Depth	25-7/8 (632)	25-7/8 (632)	26-3/16 (665)	26-3/16 (665)	26-3/8 (670)	26-3/8 (670)	26-3/8 (670)
"D1" Center Line Height of Flue*	8-1/2 (216)	8-1/2 (216)	10-3/8 (263)	10-3/8 (263)	13-5/8 (346)	13-5/8 (346)	13-5/8 (346)
"D2" Center Line Height of Air Intake	8-1/2 (216)	8-1/2 (216)	8 (203)	8 (203)	8-5/8 (219)	8-5/8 (219)	8-5/8 (219)
"E" Fan Diameter	10 (254)	10 (254)	14 (356)	14 (356)	16 (406)	16 (406)	16 (406)
"F" Discharge Opening Height	10-13/16 (275)	10-13/16 (275)	14-7/16 (367)	14-7/16 (367)	21-3/16 (538)	21-3/16 (538)	21-3/16 (538)
"G" Flue Vent Connection Diameter (Min.)	4 (102)	4 (102)	4 (102)	4 (102)	4 (102)	4 (102)	4 (102)
"H1" Center Line of Flue Connection From Side	7-1/4 (184)	7-1/4 (184)	7-1/4 (184)	7-1/4 (184)	7-3/4 (197)	7-3/4 (197)	7-1/4 (184)
"H2" Center Line of Air Intake From Side	2-3/4 (70)	2-3/4 (70)	2-3/4 (70)	2-3/4 (70)	3-1/2 (89)	3-1/2 (89)	3-1/2 (89)
Vent Size Requirements - Standard Combustion							
Category III Horizontal	4 (102)	4 (102)	4 (102)	4 (102)	4 (102)	4 (102)	4 (102)
Category I & III Vertical	4 (102)	4 (102)	4 (102)	4 (102)	4 (102)	4 (102)	4 (102)
Vent Size Requirements - Separated Combustion							
Exhaust Diameter	4 (102)	4 (102)	4 (102)	4 (102)	5 (127)	5 (127)	5 (127)
Intake Air Diameter	4 (102)	4 (102)	4 (102)	4 (102)	5 (127)	5 (127)	5 (127)
Unit Weight - lbs.	60	65	80	85	95	105	110
(kgs)	(27)	(29)	(36)	(39)	(43)	(48)	(50)
Shipping Weight - lbs.	70	75	90	95	110	115	120
(kgs)	(32)	(34)	(41)	(43)	(50)	(52)	(54)

* For all installations, the flue collar is included with the unit and should be field installed per the instructions included with the unit.

† Ratings shown are for unit installations at elevations between 0 and 2,000 feet (0 to 610m). For unit installations in U.S.A. above 2,000 feet (610m), the unit input must be derated 4% for each 1,000 feet (305m) above sea level; refer to local codes, or in absence of local codes, refer to the latest edition of the National Fuel Gas Code, ANSI Standard Z223.1 (NFPA No. 54), (also refer to Table 8).

For installations in Canada, any reference to deration at altitudes in excess of 2,000 feet (610m) are to be ignored. At altitudes of 2,000 feet to 4,500 feet (610 to 1372m), the unit must be derated and be so marked in accordance with the ETL certification. See Table 8 for USA and Canadian field deration information.

††LEGEND: ODP = OPEN DRIP PROOF SP = SHADED POLE

Figure 2 - Dimensional Drawing – Tubular 30 thru 120 Propeller Unit Heater

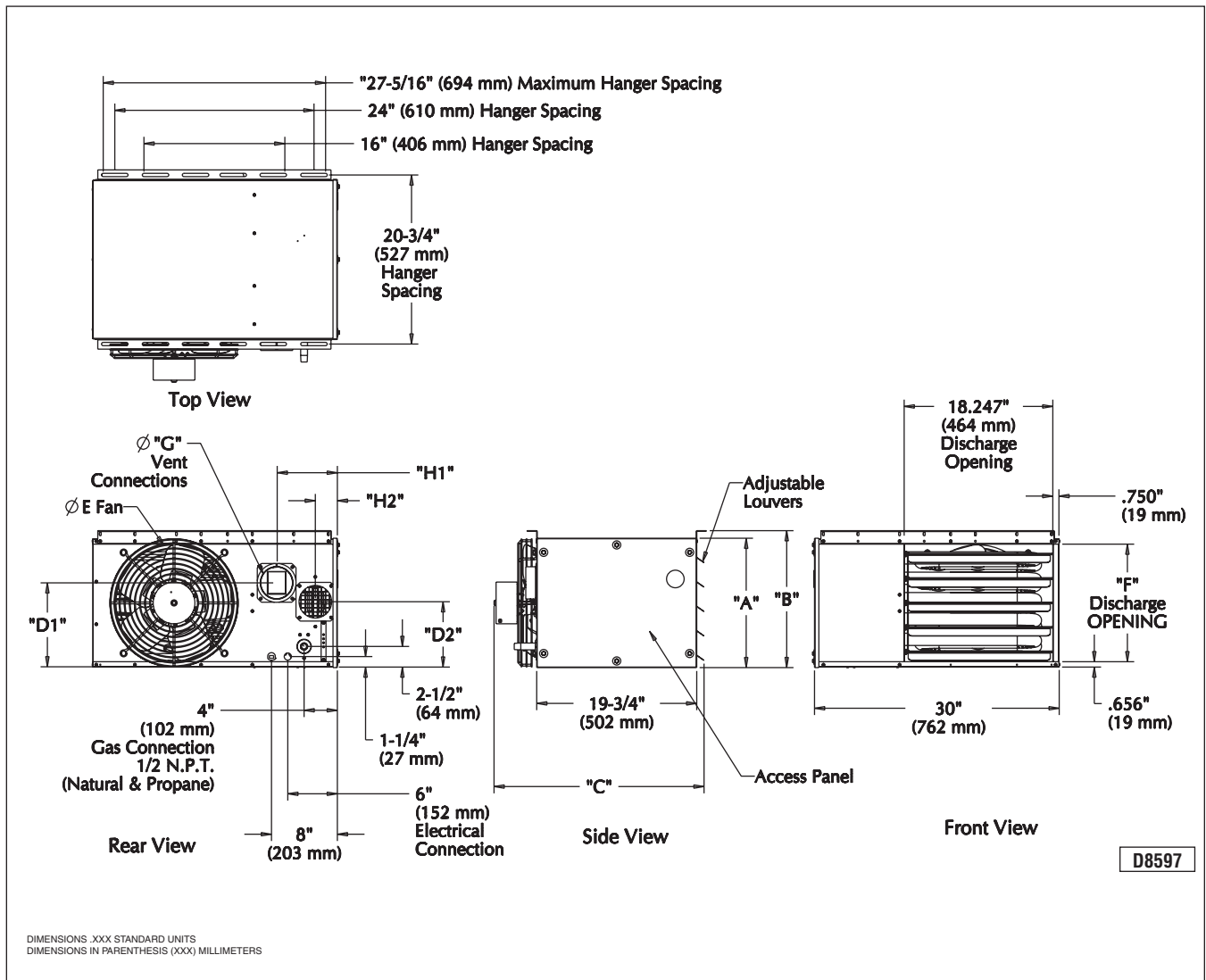

Table 2 - Heat Throw Data



Standard Unit Heater Applications

Distance From Floor to Bottom of Unit "H" - Feet (m)	UNIT SIZE BTU/Hr						
	30,000	45,000	60,000	75,000	90,000	105,000	120,000
	Approximate Distance of Heat Throw - Feet (Meters)						
8 (2.4)	33 (10.1)	33 (10.1)	33 (10.1)	40 (12.2)	40 (12.2)	60 (18.3)	65 (19.8)
10 (3.0)	28 (8.5)	28 (8.5)	28 (8.5)	35 (10.7)	35 (10.7)	54 (16.5)	56 (17.1)
12 (3.7)	NR	NR	NR	NR	NR	44 (13.4)	46 (14.0)
15 (4.6)	NR	NR	NR	NR	NR	NR	NR

Notes:

1. All throw data figures are approximations. Allowances should be made for optimum performance, altitude, etc.
2. NR - Units not recommended at these mounting heights.

INSTALLATION

▲ WARNING Do not install unit heaters in corrosive or flammable atmospheres! Premature failure of, or severe damage to the unit will result!

▲ WARNING Avoid locations where extreme drafts can affect burner operation. Unit heaters must not be installed in locations where air for combustion would contain chlorinated, halogenated or acidic vapors. If located in such an environment, premature failure of the unit will occur!

Since the unit is equipped with an automatic gas ignition system, the unit heater must be installed such that the gas ignition control system is not directly exposed to water spray, rain or dripping water.

NOTICE: Location of unit heaters is related directly to the selection of sizes. Basic rules are as follows:

MOUNTING HEIGHT: If the unit heater is installed in a garage, it must be installed with a minimum clearance above the floor of 18 inches (457mm).

AIR DISTRIBUTION: Direct air towards areas of maximum heat loss. When multiple heaters are involved, circulation of air around the perimeter is recommended where heated air flows along exposed walls. Satisfactory results can also be obtained where multiple heaters are located toward the center of the area with heated air directed toward the outside walls. Be careful to avoid all obstacles and obstructions which could impede the warm air distribution patterns.

Unit heaters should not be installed to maintain low temperatures and/or freeze protection of buildings. A minimum of 50°F (10°C) thermostat setting must be maintained. If unit heaters are operated to maintain lower than 50°F (10°C), hot flue gases are cooled inside the heat exchanger to a point where water vapor (a flue gas by-product) condenses onto the heat exchanger walls. The result is a mildly corrosive acid that prematurely corrodes the aluminized heat exchanger and can actually drip water down from the unit heater onto floor surface. Additional unit heaters should be installed if a minimum 50°F (10°C) thermostat setting cannot be maintained.

▲ WARNING Should overheating occur, or the gas supply fail to shut off, shut off the manual gas valve to the appliance before shutting off the electrical supply.

▲ WARNING Do not use this appliance if any part has been under water. Immediately call a qualified service technician to inspect the appliance and replace any gas control which has been underwater.

AIR FOR COMBUSTION: The unit heater shall be installed in a location in which the facilities for ventilation permit satisfactory combustion of gas, proper venting, and the maintenance of ambient air at safe limits under normal conditions of use. The unit heater shall be located in such a manner as not to interfere with proper circulation of air within the confined space. When buildings are so tight that normal infiltration does not meet air requirements, outside air shall be introduced per Sections 1.3.4.2 and 1.3.4.3 of ANSI Z223.1 (NFPA 54) for combustion requirements. A permanent opening or openings having a total free area of not less than one square inch per 5,000 BTU/Hr (1.5 kW) of total input rating of all appliances within the space shall be provided.

NOTICE: Unit Heater sizing should be based on heat loss calculations where the unit heater output equals or exceeds heat loss.

CLEARANCES: Each Gas Unit Heater shall be located with respect to building construction and other equipment so as to permit access to the Unit Heater. Clearance between vertical walls and the vertical sides of the Unit Heater shall be no less than 1 inch (25.4mm). However, to ensure access to the control box and fan, a minimum of 18 inches (457mm) is required for the fan, and control box side. A minimum clearance of 1 inch (25.4mm) must be maintained between the top of the Unit Heater and the ceiling. The bottom of the Unit Heater must be no less than 1 inch (25.4mm) from any combustible. The distance between the flue collector and any combustible must be no less than 1 inch (25.4mm). Also see AIR FOR COMBUSTION and VENTING sections.

NOTICE: Increasing the clearance distances may be necessary if there is a possibility of distortion or discoloration of adjacent materials.

MOUNTING: The Unit Heater may be mounted with the vent outlet, gas and electrical connections to the right or left of the air moving fan. The Unit Heater is shipped with the connections to the right of the fan when looking in the direction of the air flow. If connections to the right are required, remove hanger brackets from face of unit and attach as pictured in Figure 3. If connections to the left are required, invert the heater (180°), mount the hanging brackets as above, and remove, invert, and replace the air discharge louvers.

INSTALLATION (continued)

The Unit Heater may be mounted by fastening the hanging brackets directly to ceiling joists or by suspending from four rods. See Figures 3, 4 and 5.

▲ WARNING Make certain that the lifting methods used to lift the heater and the method of suspension used in the field installation of the heater are capable of uniformly supporting the weight of the heater at all times. Failure to heed this warning may result in property damage or personal injury!

▲ WARNING Make sure that the structure to which the unit heater is to be mounted is capable of safely supporting its weight. Under no circumstances must the gas lines, the venting system or the electrical conduit be used to support the heater; or should any other objects (i.e. ladder, person) lean against the heater gas lines, venting system or the electrical conduit for support. Failure to heed these warnings may result in property damage, personal injury, or death.

▲ CAUTION Unit Heaters must be hung level from side to side and from front to back, see Figures 3, 4 and 5. Failure to do so will result in poor performance and/or premature failure of the unit.

▲ WARNING Ensure that all hardware used in the suspension of each unit heater is more than adequate for the job. Failure to do so may result in extensive property damage, severe personal injury, or death!

Refer to Figures 3, 4 and 5 for suspension of units.

Figure 3 - Hanger Bracket Installation Instructions

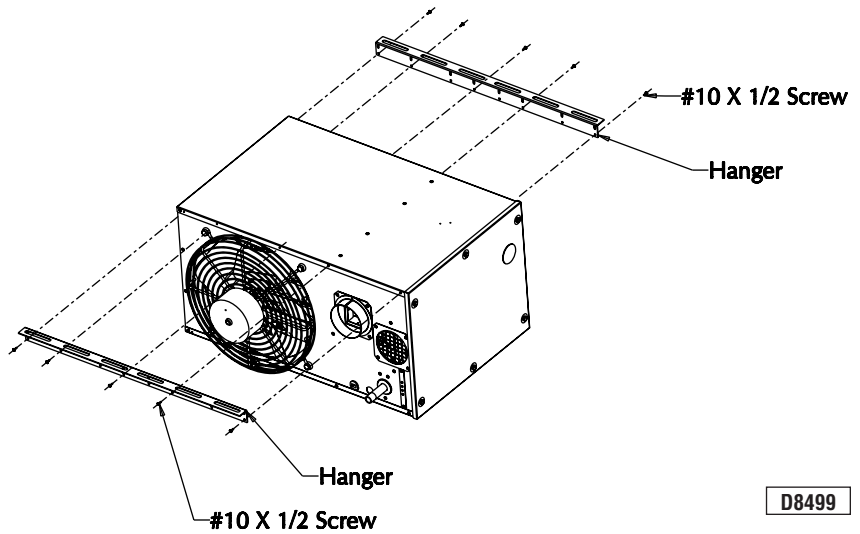

Install Hangers To Front And Rear Of Unit With #10 X 1/2 Screws (10) Plcs As Shown

D8499

Figure 4 - Heater Mounting (Steel Construction)

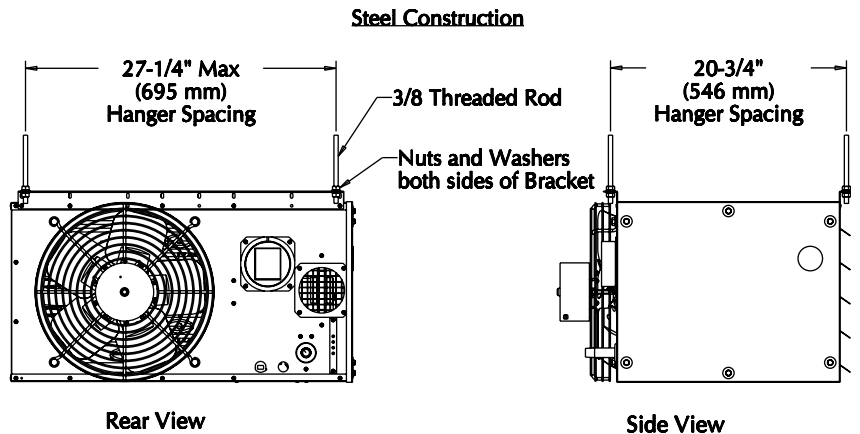

Rear View

Side View

D8598

Figure 5 - Heater Mounting (Wood Construction)

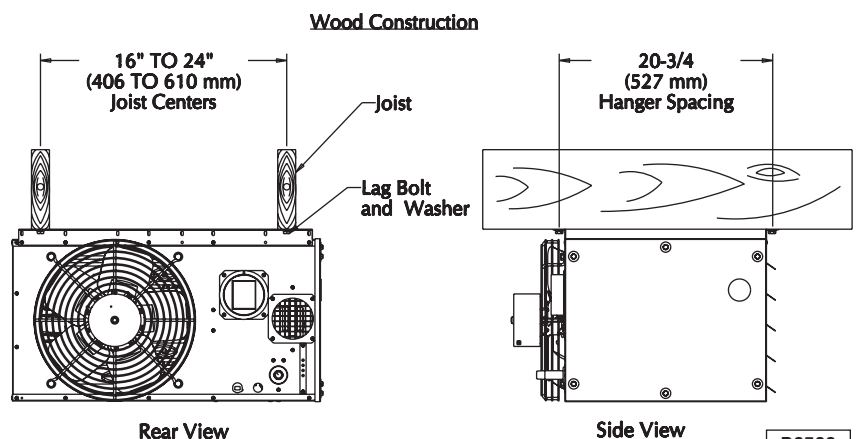

Rear View

Side View

D8599

GAS PIPING

▲ WARNING To avoid damage or possible personal injury, do not connect gas piping to this unit until a supply line pressure/leak test has been completed. Connecting the unit before completing the pressure/leak test may damage the unit gas valve and result in a fire hazard.

▲ WARNING Do not rely on a shut-off valve to isolate the unit while conducting gas pressure/leak tests. These valves may not be completely shut off, exposing the gas valve to excessive pressure and damage.

PIPE SIZING

To provide adequate gas pressure to the gas unit heater, size the gas piping as follows:

- Find the cu. ft./hr. by using the following formula:

$$\text{Cu. feet/hr.} = \frac{\text{Input}}{\text{BTU}}$$

- Refer to Table 3. Match "Length of Pipe in Feet" with appropriate "Gas Input - Cu. Feet/Hr." figure. This figure can then be matched to the pipe size at the top of the column.

Example:

It is determined that a 67 foot (20.4m) run of gas pipe is required to connect a 75 MBTU gas unit heater to a 1,000 BTU/cu feet (0.29kW) natural gas supply.

$$\frac{75,000 \text{ BTU/Hr}}{1,000 \text{ BTU/cu. feet}} = 75 \text{ Cu. feet/hr}$$

Using Table 3, a 3/4 inch pipe is needed.

NOTE: See General Safety Information section for English/Metric unit conversion factors.

NOTICE: Propane tank must be properly sized for outdoor temperature and BTU requirement. (See NFPA 58)

NOTICE: If more than one unit heater is to be served by the same piping arrangement, the total cu. ft./hr. input and length of pipe must be considered.

NOTICE: If the gas unit heater is to be fired with LP gas, consult your local LP gas dealer for pipe size information.

NOTICE: HEATER INSTALLATION FOR USE WITH PROPANE (BOTTLED) GAS MUST BE MADE BY A QUALIFIED L.P. GAS DEALER OR INSTALLER. HE WILL ENSURE THAT PROPER JOINT COMPOUNDS ARE USED FOR MAKING PIPE CONNECTIONS; THAT AIR IS PURGED FROM LINES; THAT A THOROUGH TEST IS MADE FOR LEAKS BEFORE OPERATING THE HEATER; AND THAT IT IS PROPERLY CONNECTED TO THE PROPANE GAS SUPPLY SYSTEM.

Before any connection is made to the existing line supplying other gas appliances, contact the local gas company to make sure that the existing line is of adequate size to handle the combined load.

Table 3 - Gas Pipe Size

Maximum Capacity of Pipe in Cubic Feet of Gas per Hour (Cubic Meters per Hour) for Gas Pressures of 0.5 psig (3.5 kPa) or Less, and a Pressure Drop of 0.5 Inch Water Column (124.4 Pa)
(Based on a 0.60 Specific Gravity Gas)

Nominal Iron	Internal Diameter	Length of Pipe, Feet (meters)													
		10 (3.0)	20 (6.1)	30 (9.1)	40 (12.2)	50 (15.2)	60 (18.3)	70 (21.3)	80 (24.4)	90 (27.4)	100 (30.5)	125 (38.1)	150 (45.7)	175 (53.3)	200 (61.0)
1/2	0.622	175 (4.96)	120 (3.40)	97 (2.75)	82 (2.32)	73 (2.07)	66 (1.87)	61 (1.73)	57 (1.61)	53 (1.50)	50 (1.42)	44 (1.25)	40 (1.13)	37 (1.05)	35 (0.99)
3/4	0.824	360 (10.2)	250 (7.08)	200 (5.66)	170 (4.81)	151 (4.28)	138 (3.91)	125 (3.54)	118 (3.34)	110 (3.11)	103 (2.92)	93 (2.63)	84 (2.38)	77 (2.18)	72 (2.04)
1	1.049	680 (19.3)	465 (13.2)	375 (10.6)	320 (9.06)	285 (8.07)	260 (7.36)	240 (6.80)	220 (6.23)	205 (5.80)	195 (5.52)	175 (4.96)	160 (4.53)	145 (4.11)	135 (3.82)
1 1/4	1.380	1400 (39.6)	950 (26.9)	770 (21.8)	660 (18.7)	580 (16.4)	530 (15.0)	490 (13.9)	460 (13.0)	430 (12.2)	400 (11.3)	360 (10.2)	325 (9.20)	300 (8.50)	280 (7.93)
1 1/2	1.610	2100 (59.5)	1460 (41.3)	1180 (33.4)	990 (28.0)	900 (25.5)	810 (22.9)	750 (21.2)	690 (19.5)	650 (18.4)	620 (17.6)	550 (15.6)	500 (14.2)	460 (13.0)	430 (12.2)
2	2.067	3950 (112)	2750 (77.9)	2200 (62.3)	1900 (53.8)	1680 (47.6)	1520 (43.0)	1400 (39.6)	1300 (36.8)	1220 (34.5)	1150 (32.6)	1020 (28.9)	950 (26.9)	850 (24.1)	800 (22.7)
2 1/2	2.469	6300 (178)	4350 (123)	3520 (99.7)	3000 (85.0)	2650 (75.0)	2400 (68.0)	2250 (63.7)	2050 (58.0)	1950 (55.2)	1850 (52.4)	1650 (46.7)	1500 (42.5)	1370 (38.8)	1280 (36.2)
3	3.068	11000 (311)	7700 (218)	6250 (177)	5300 (150)	4750 (135)	4300 (122)	3900 (110)	3700 (105)	3450 (97.7)	3250 (92.0)	2950 (83.5)	2650 (75.0)	2450 (69.4)	2280 (64.6)
4	4.026	23000 (651)	15800 (447)	12800 (362)	10900 (309)	9700 (275)	8800 (249)	8100 (229)	7500 (212)	7200 (204)	6700 (190)	6000 (170)	5500 (156)	5000 (142)	4600 (130)

1. Determine the required Cu. Feet/Hr. by dividing the input by 1000. For SI/Metric measurements: Convert BTU/Hr. to kilowatts. Multiply the units inputs (kW) by 0.0965 to determine Cu. Meters./Hr. 2. FOR NATURAL GAS: Select pipe size directly from the table. 3. FOR PROPANE GAS: Multiply the Cu. Feet/Hr. value by 0.633; then, use the table. 4. Refer to the metric conversion factors listed in the General Safety section for SI Unit measurement conversions.

PIPE INSTALLATION

1. Install the gas piping in accordance with applicable local codes.
2. Check gas supply pressure. Each unit heater must be connected to a gas supply capable of supplying its full rated capacity as specified in Table 4. A field LP tank regulator must be used to limit the supply pressure to a maximum of 14 inches W.C. (3.5 kPa). All piping should be sized in accordance with the latest edition of ANSI Standard Z223.1 (NFPA 54) National Fuel Gas Code; in Canada, according to CSA-B149. See Tables 1 & 3 for correct gas piping size, and also refer to Tables 4, 7 and 8. If gas pressure is excessive on natural gas applications, install a pressure regulating valve in the line upstream from the main shutoff valve.
3. Adequately support the piping to prevent strain on the gas manifold and controls.
4. To prevent the mixing of moisture with gas, run the take-off piping from the top, or side, of the main.
5. Standard Unit Heaters are supplied with a combination valve which includes:
 - a. Manual "A" valve
 - b. Manual "B" valve
 - c. Solenoid valve
 - d. Pressure regulator
 Pipe directly into the combination valve (see Figure 6).
6. Gas valve has a pressure test post requiring a 3/32 inch hex head wrench to read gas supply and manifold pressures. Open 1/4 turn counterclockwise to read, turn clockwise to close and reseal. A 5/16 inch ID hose fits the pressure post.
7. Provide a drip leg in the gas piping near the gas unit heater. A ground joint union and a manual gas shutoff valve should be installed ahead of the unit heater controls to permit servicing. The manual shutoff valve must be located external to the jacket. (See Figure 6)
8. Make certain that all connections have been adequately doped and tightened.

Table 4 - Gas Piping Requirements

GAS PIPING REQUIREMENTS*		
GasType	Natural Gas	Propane (LP) Gas
Manifold Pressure	3.5 inch WC (0.9 kPa)	10.0 inch WC (2.5 kPa)
Supply Inlet Pressure	14.0 inch WC Max. (3.5 kPa)	14.0 inch WC Max. (3.5 kPa)
	5.0 inch WC Min. (1.2 kPa)	11.0 inch WC Min. (2.7 kPa)

*For single stage application only at altitudes below 2,001 feet.

▲ CAUTION Do not over tighten the inlet gas piping into the valve. This may cause stresses that will crack the valve!

NOTICE: Use pipe joint sealant resistant to the action of liquefied petroleum gases regardless of gas conducted.

▲ WARNING Check all pipe joints for leakage using a soap solution or other approved method. Never use an open flame or severe personal injury or death may occur!

Figure 6 - Pipe Installation, Standard Controls

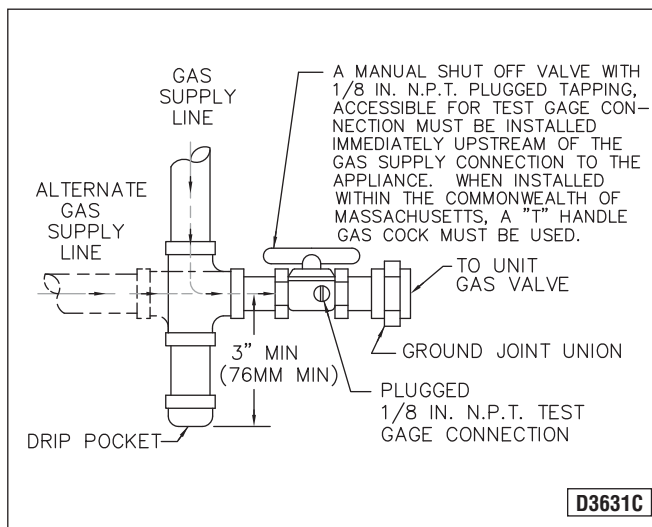

▲ WARNING Never use an open flame to detect gas leaks. Explosive conditions may exist which may result in personal injury or death!

The appliance and its individual shutoff valve must be disconnected from the gas supply piping system during any pressure testing of that system in excess of 1/2 psig (3.5 kPa).

The appliance must be isolated from the gas supply piping system by closing its individual manual shutoff valve during any pressure testing of the gas supply piping system at test pressures equal to or less than 1/2 psig (3.5 kPa).

ELECTRICAL CONNECTIONS



▲ WARNING

HAZARDOUS VOLTAGE!
DISCONNECT ALL ELECTRIC POWER INCLUDING REMOTE DISCONNECTS BEFORE SERVICING. Failure to disconnect power before servicing can cause severe personal injury or death.

Standard units are shipped for use on 115 volt, 60 hertz, single phase electric power. The motor name-plate and electrical rating of the transformer should be checked before energizing the unit heater electrical system. All external wiring must conform to the latest edition of ANSI/NFPA No. 70, National Electrical Code, and applicable local codes; in Canada, to the Canadian Electrical Code, Part 1, CSA Standard C22.1.

▲ CAUTION Do not use any tools (i.e. screwdriver, pliers, etc.) across terminals to check for power. Use a voltmeter.

It is recommended that the electrical power supply to each unit heater be provided by a separate, fused, and permanently live electrical circuit. A disconnect switch of suitable electrical rating should be located as close to the gas valve and controls as possible. Each unit heater must be electrically grounded in accordance with the latest edition of the National Electrical Code, ANSI/NFPA No. 70, or CSA Standard C22.1. Refer to Figures 7, 8, 9, 10A, 10B, 10C, 11A, 11B and 11C.

THERMOSTAT WIRING AND LOCATION:

NOTICE: The thermostat must be mounted on a vertical, vibration-free surface, free from air currents, and in accordance with the furnished instructions.

Mount the thermostat approximately 5 feet (1.5m) above the floor, in an area where it will be exposed to a free circulation of average temperature air. Always refer to the thermostat instructions, as well as our unit wiring diagram, and wire accordingly. Avoid mounting the thermostat in the following locations:

1. Cold Areas- Outside walls or areas where drafts may affect the operation of the control.
2. Hot Areas- Areas where the sun's rays, radiation, or warm air currents may affect the operation of the control.
3. Dead Areas- Areas where the air cannot circulate freely, such as behind doors or in corners.

NOTICE: The start-up fan delay should not exceed 30 seconds from a cold start.

IMPORTANT: For all wiring connections, refer to the wiring diagram shipped with your unit (either affixed to the side jacket or enclosed in the installation instructions envelope). Should any original wire supplied with the heater have to be replaced, it must be replaced with wiring material having a temperature rating of at least 105°C.

Figure 7 - Low-voltage Thermostat Wiring Single Stage

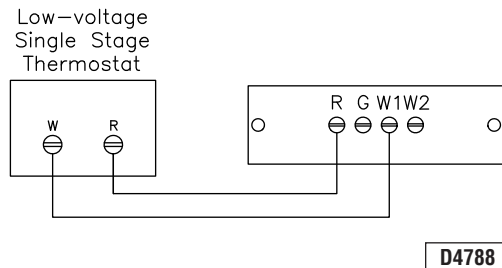

Figure 8 - Low Voltage Thermostat Wiring Two Stage

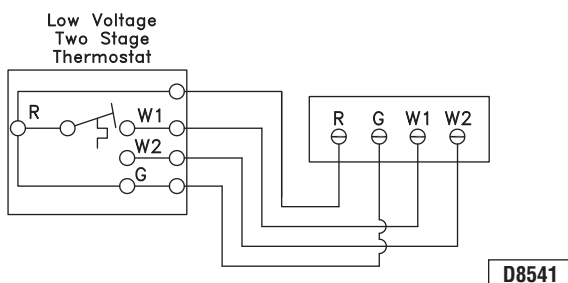
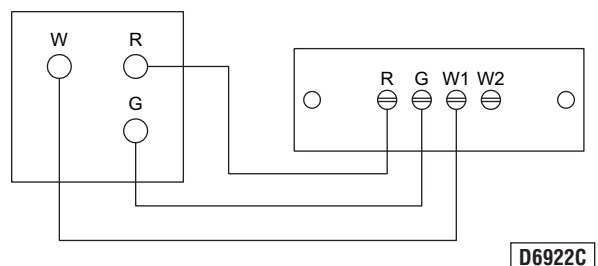
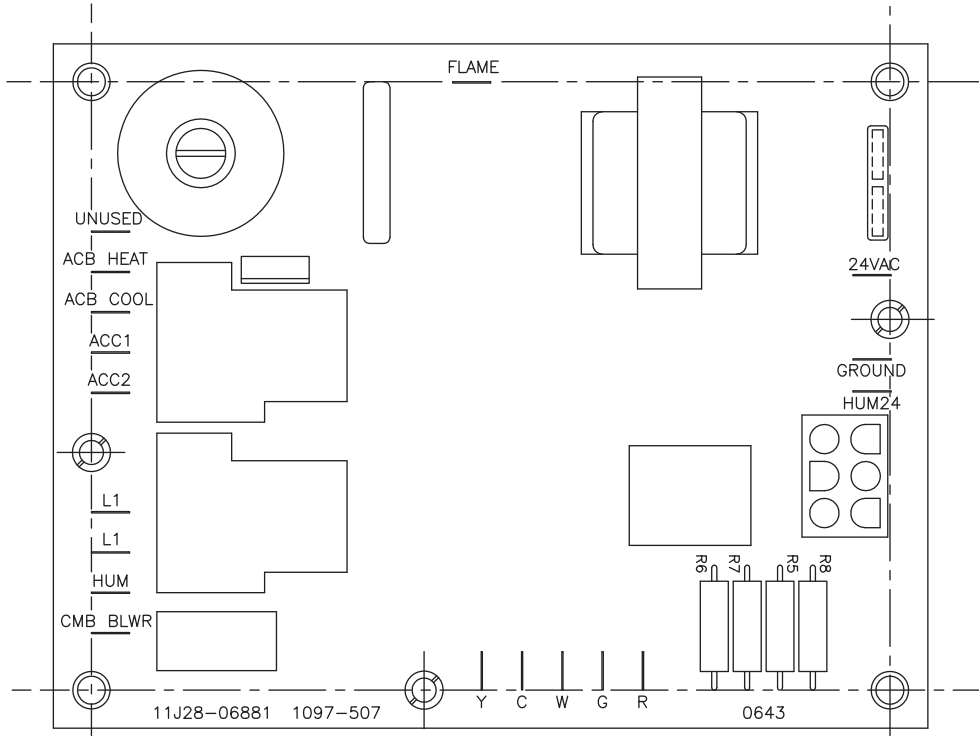

Figure 9 - T834H or T834N Thermostat Wiring



ELECTRICAL CONNECTIONS (continued)

Figure 10A - UT Control Board



D8604

Figure 11A - Honeywell Control Board

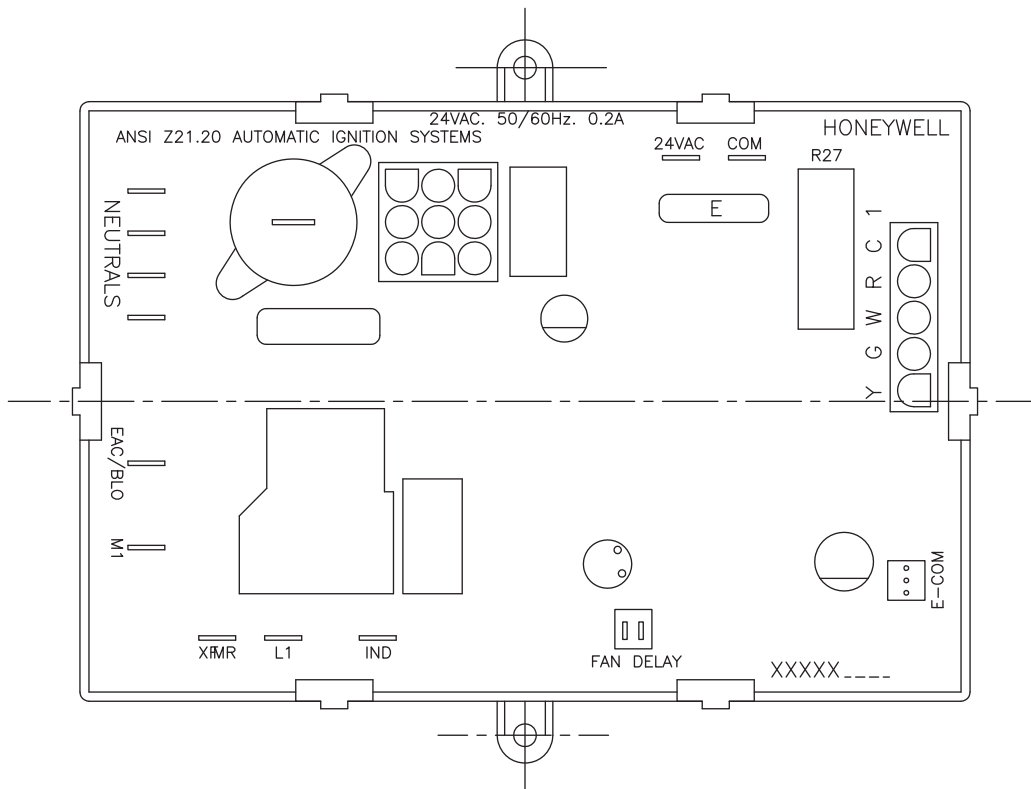

D8605

ELECTRICAL CONNECTIONS (continued)

Figure 10B - Tubular Propeller Units 30-120 with Natural and Propane (LP) Gas with Single Stage Gas Control and UT Control Board

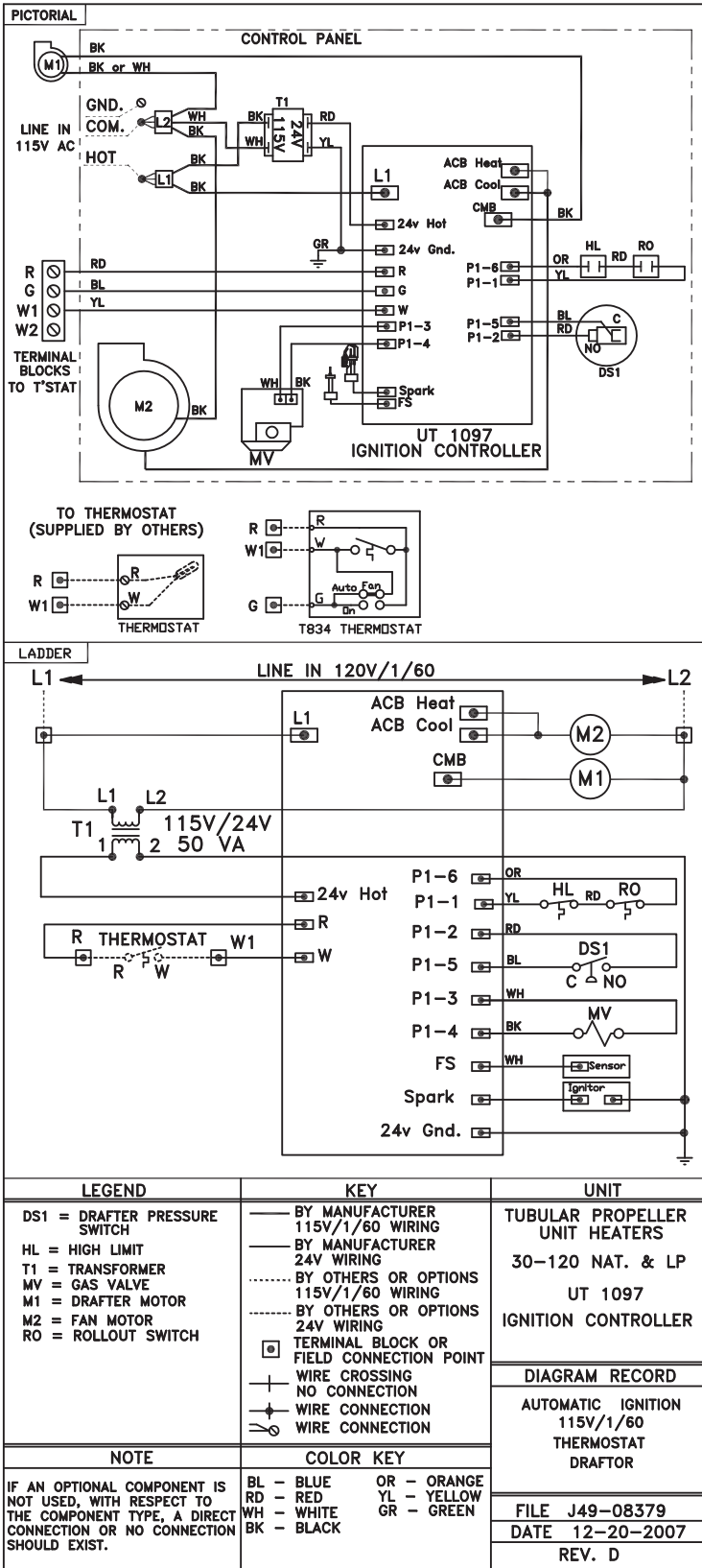

NOTICE: See Figures 7, 8, 9, 10B, 10C, 11B and 11C for connecting the thermostat to the unit heater. If using a standard low voltage thermostat with a sub-base switch for fan control, connect the G terminal of the thermostat to the G terminal of the unit heater.

ELECTRICAL CONNECTIONS (continued)

Figure 11B - Tubular Propeller Units 30-120 with Natural and Propane (LP) Gas with Single Stage Gas Control and Honeywell Control Board

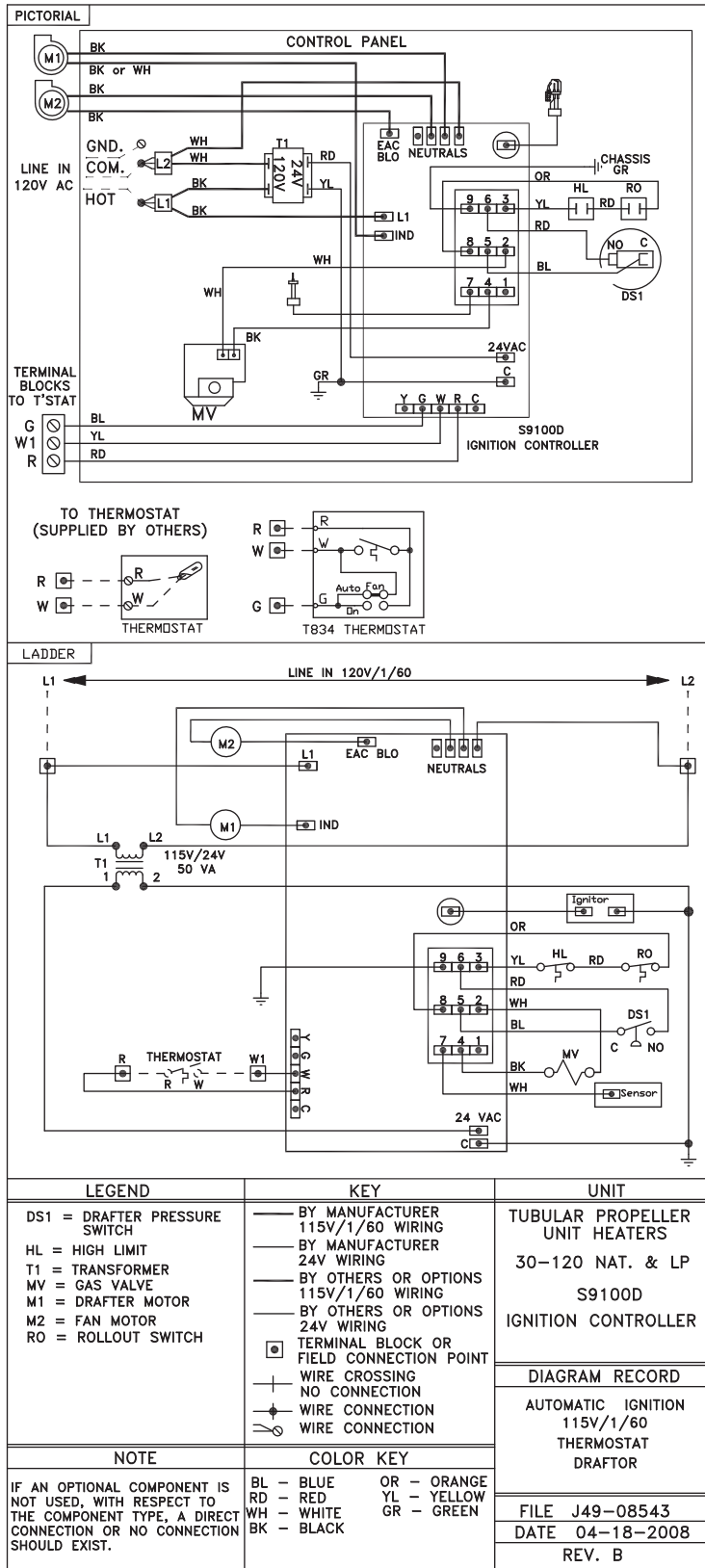

NOTICE: See Figures 7, 8, 9, 10B, 10C, 11B and 11C for connecting the thermostat to the unit heater. If using a standard low voltage thermostat with a sub-base switch for fan control, connect the G terminal of the thermostat to the G terminal of the unit heater.

ELECTRICAL CONNECTIONS (continued)

Figure 11C - Tubular Propeller Units 60-120 with Natural and Propane (LP) Gas with Optional Two Stage Gas Control and Honeywell Control Board

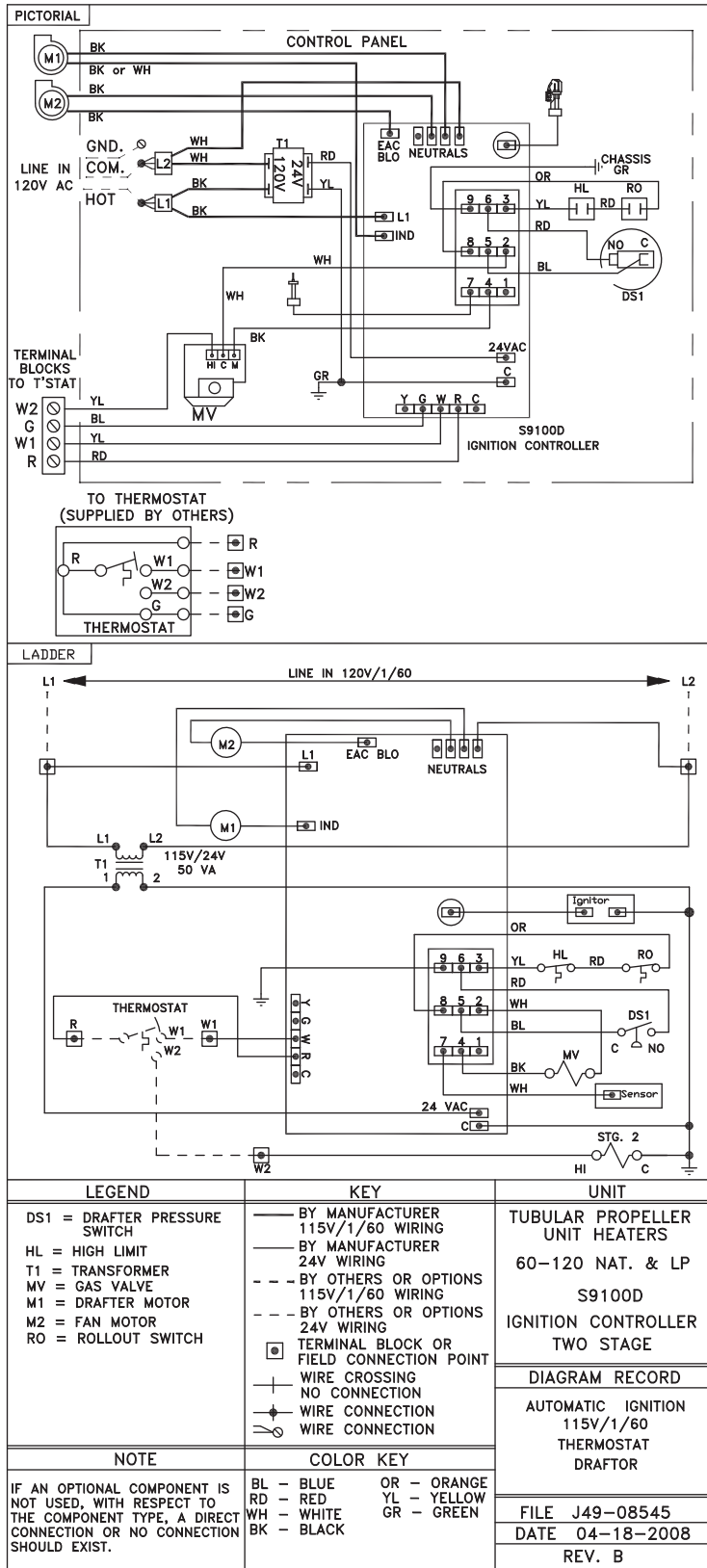

NOTICE: See Figures 7, 8, 9, 10B, 10C, 11B and 11C for connecting the thermostat to the unit heater. If using a standard low voltage thermostat with a sub-base switch for fan control, connect the G terminal of the thermostat to the G terminal of the unit heater.

VENTING*

All unit heaters must be vented! All Venting installations shall be in accordance with the latest edition of Part 7, Venting of Equipment of the National Fuel Gas Code, ANSI Z223.1 (NFPA 54), or applicable provisions of local building codes. All venting of residential tubular unit heaters must comply with CSA International Requirements 10.96 U.S. for Unit Heaters for Residential Use (2nd Edition). Refer to notes* below for Canadian installations. Refer to Figures 12-17.

▲ WARNING **CARBON MONOXIDE! Your venting system must not be blocked by any snow, snow drifts, or any foreign matter. Inspect your venting system to ensure adequate ventilation exists at all times! Failure to heed these warnings could result in Carbon Monoxide Poisoning (symptoms include grogginess, lethargy, inappropriate tiredness, or flue-like symptoms).**

When an existing heater is removed or replaced in venting system, the venting system may not be properly sized to vent the attached appliances. An improperly sized vent system can cause formulation of condensate or leakage or spillage of flue gases.

The following steps shall be followed with each appliance connected to the venting system placed in operation, while any other appliances connected to the venting system are not in operation:

1. Seal any unused openings in the venting system;
2. Inspect the venting system for proper size and horizontal pitch, as required in the National Fuel Gas Code, ANSI Z223.1 (NFPA 54) and these instructions. Determine that there is no blockage or restriction, leakage, corrosion and other deficiencies, which could cause an unsafe condition.
3. In so far as practical, close all building doors and windows and all doors between the space in which the appliance(s) connected to the venting system are located and other spaces of the building. Turn on clothes dryers and any exhaust fans, such as range hoods and bathroom exhausts, so they shall operate at maximum speed. Do not operate a summer exhaust fan. Close fireplace damper.
4. Follow the lighting instructions. Place the appliance being inspected in operation. Adjust thermostat so that the appliance will operate continuously.
5. After it has been determined that each appliance connected to the venting system properly vents when tested as outline above, return doors, windows, exhaust fans, fireplace dampers, and any other gas-burning appliance to their previous condition of use.
6. If improper venting is observed during any of the above tests, the venting system must be corrected immediately so that the system conforms with the National Fuel Gas Code, ANSI Z223.1 (NFPA 54). When resizing any portion of the venting system, the venting system should be resized to approach the minimum size as determined using the appropriate tables in Appendix G of the National Fuel Gas Code, ANSI Z223.1 (NFPA 54).

The unit heater shall be connected to a factory built chimney or vent complying with a recognized standard, or a masonry or concrete chimney lined with a lining material acceptable to the authority having jurisdiction. **Venting into an unlined masonry chimney is prohibited.**

ADDITIONAL REQUIREMENTS FOR CANADIAN INSTALLATIONS

*The following instructions apply to Canadian installations in addition to installation and operating instructions.

1. Installation must conform with local building codes, or in the absence of local codes, with current CSA-B149.1, Installation Codes for Natural Gas Burning Appliances and Equipment, or CSA-B149.2, Installation Codes for Propane Gas Burning Appliances and Equipment.
2. Any reference to U.S. standards or codes in these instructions are to be ignored and the applicable Canadian standards or codes applied.

VENTING - GENERAL GUIDELINES

The following guidelines apply to all categories to follow.

Table 5

Vent Systems Termination Clearance Requirements		
Structure/Object	Minimum Clearance for Termination Locations	
	USA	CANADA
Door, window, or gravity vent inlet; combustion air inlet for other appliances	9 inches for 10,000 to 50,000 BTU/Hr input; 12 inches for input exceeding 50,000 BTU/Hr.	9 inches (230mm) for 10,000 to 50,000 BTU/Hr input; 12 inches (305mm) for input exceeding 50,000 BTU/Hr.
Forced air inlet within 10 ft.	3 feet above	6 feet (1.8m)
Adjoining Building or parapet	10 feet	10 feet (3.04m)
Adjacent public walkways	7 feet above grade	7 feet (2.1m) above grade
Electric, gas meters & regulators	4 feet horizontal	3 feet (0.9m) horizontally from meter/regulator assembly. 6 feet (1.8m), any direction, from a gas service regulator vent outlet
Above grade level*	1 feet	1 feet (0.3m)

*Minimum above maximum snow depth, or per local code, whichever is greater.

Do not damper or add heat recovery devices to the flue piping. Failure to open such a damper prior to operating the gas unit heater will result in the spillage of flue gas into the occupied space.

Avoid installing units in areas under negative pressure. When required, a flue vent fan should be installed in accordance with the instructions included with the fan.

Vent connectors serving Category I and Category II heaters shall not be connected into any portion of mechanical draft systems operating under positive vent pressure.

Maintain clearance between the vent pipe and combustible materials according to vent pipe manufacturer's instructions.

ANSI now organizes vented appliances into four categories.

Venting Categories

	Non Condensing	Condensing
Negative Vent Pressure	I	II
Positive Vent Pressure	III	IV

Category I

Includes non-condensing appliances with negative vent pressure, like the traditional atmospheric unit heater.

Category II

Groups condensing appliances with negative vent pressure.

Category III

Appliances are non-condensing and operate with a positive vent pressure.

Category IV

Covers condensing appliances with positive vent pressure.

NOTICE: Category II and IV do not apply to equipment specified within this manual.

STANDARD COMBUSTION

VERTICALLY VENTED, CATEGORY I - Figure 12

Observe the following precautions when venting the unit:

1. Use flue pipe of the same size as the flue connection(s) on the gas unit heater 4 inches (102mm). All heaters must be vented with a UL 1738 listed, double or single wall vent, Type B vent, a factory built chimney, or a lined brick and mortar chimney that has been constructed in accordance with the National Building Code. All tables and dimensions assume double wall for the flue and single wall pipe or double wall for the connector.
2. **Each unit must have an individual vent pipe and vent terminal.** Unit MUST NOT be connected to other vent systems or to a chimney.
3. A minimum vertical rise of 5 feet (1.5m) is required for Category I venting. The top of the vent pipe should extend at least 2 feet (0.61m) above the highest point on the roof. Consideration should be made for anticipated snow depth. Install an Amerivent Americap or Metalbestos vent cap over the vent opening.
4. Slope horizontal runs upward from the gas unit heater at least 1/4-inch per foot (21mm/m) minimum. Horizontal Vent Connector length should not exceed 75% of the vertical height of the vent pipe. Maximum vent connector length is 10 feet (3m). For exceptions see Ch. 10 of the National Fuel Gas Code, ANSI Z223.1 (NFPA 54). Horizontal portions of the venting system shall be supported at minimum intervals of 4 feet (1.2m) (in Canada, support at 3 foot (1m) minimum intervals). Maintain clearance between the vent pipe and combustible materials per vent pipe manufacturer's instructions.
5. Use as few elbows as possible.
6. Seal all vent pipe joints and seams to prevent leakage. Use General Electric RTV-108, Dow-Corning RTV-732, or equivalent silicone sealant with a temperature rating of 500°F, or 3M #425 aluminum foil tape (or equivalent). See Figure 12A.
7. Avoid running vent pipe through unheated spaces. When this cannot be avoided, insulate the pipe to prevent condensation of moisture on the walls of the pipe. Insulate vent pipe runs longer than 10 ft (3m). Insulation should be a minimum of 1/2 inch (12.7 mm) thick foil faced.

Figure 12 - Vertically Vented, Category I

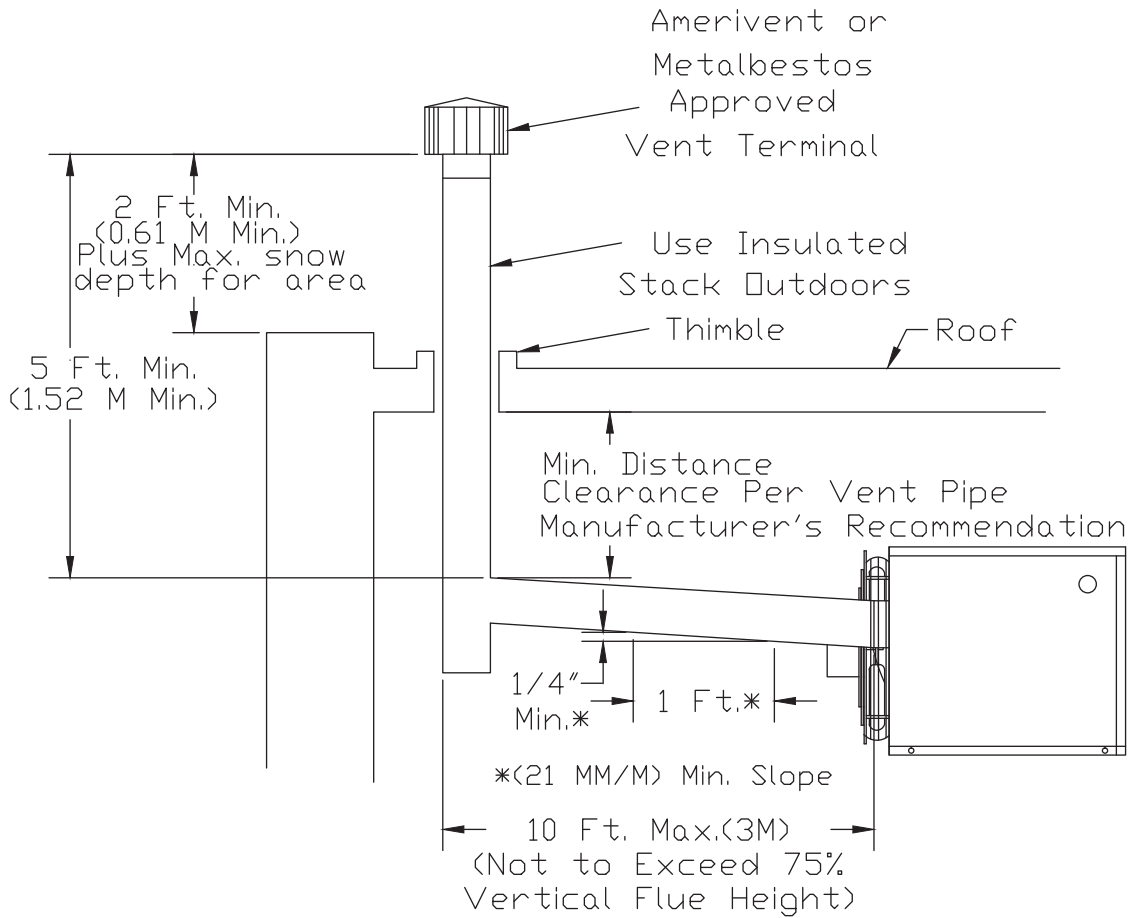

D9257

Figure 12A - Double Wall Draft Hood Connector

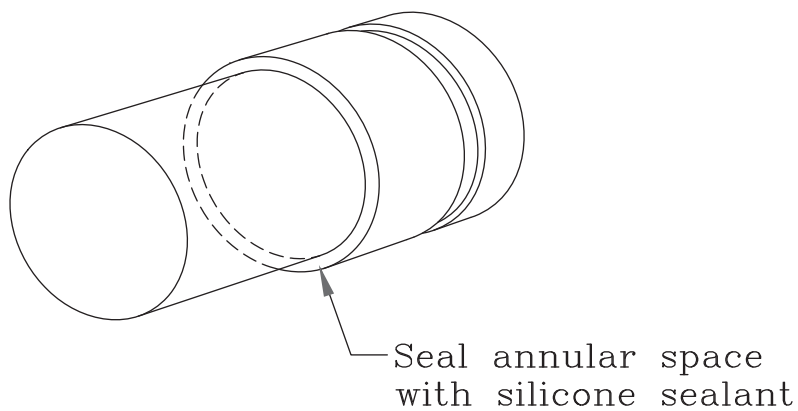

D06880

STANDARD COMBUSTION

HORIZONTALLY VENTED, CATEGORY III - Figures 13A, 14 & 16

Observe the following precautions when venting the unit:

1. Use flue pipe of the same size as the flue connection(s) on the gas unit heater, 4 inches (102mm). All heaters must be vented with a single or double wall pipe listed for category III positive pressure vent systems. (UL 1738 listed AL29-4C).
2. **Each unit must have an individual vent pipe and vent terminal.** Unit MUST NOT be connected to other vent systems or to a chimney.
3. Category III units are limited to a maximum of 40 feet (12.19m) equivalent length of vent pipe. Equivalent length is the total length of straight sections PLUS 5 feet (1.5m) for each 90 degree elbow and 2.5 feet (.75m) for each 45 degree elbow.
4. An Amerivent Americap or Metalbestos vent cap must be supplied by the customer for each power vented unit. The vent pipe diameter must be 4 inches (102mm).
5. The vent terminal must be at least 12 inches (305mm) from the exterior of the wall that it passes through to prevent degradation of the building materials by flue gasses.
6. Through the wall venting for these appliances shall not terminate over public walkways, or over an area where the condensate or vapor could create a nuisance, hazard, or could be detrimental to the operation of regulators, relief valves, or other equipment. See Figures 13A, 14, 16 and Table 5.
7. Maintain clearance between the vent pipe and combustible materials according to vent pipe manufacturer's instructions.
8. The vent system must be installed to prevent collection of condensate. Pitch horizontal pipes downward 1/4 inch per foot (21mm per meter) toward the outlet for condensate drainage. Install a tee with a condensate drain at the low point of the pipe (see Figure 13A). As an alternate, a 3/8 inch diameter hole may be drilled at the low point of the pipe for condensate drainage.
9. Horizontal portions of the venting system shall be supported at minimum intervals of 4 feet (1.2m) to prevent sagging (in Canada, support at 3 foot (1m) minimum intervals).
10. Avoid running vent pipe through unheated spaces. When this cannot be avoided, insulate the pipe to prevent condensation of moisture on the walls of the pipe. Insulate vent pipe runs longer than 10 feet (3m). Insulation should be a minimum of 1/2 inch (12.7mm) thick foil faced.

VERTICALLY VENTED, CATEGORY III – Figures 13B, 15 & 17

Observe the following precautions when venting the unit:

1. Use flue pipe of the same size as the flue connection(s) on the gas unit heater, 4 inches (102mm). All heaters must be vented with a UL 1738 listed single or double wall pipe listed for positive pressure vent systems.
2. **Each unit must have an individual vent pipe and vent terminal.** Unit MUST NOT be connected to other vent systems or to a chimney.
3. Category III units are limited to a maximum of 40 feet (12.19m) equivalent length of vent pipe. Equivalent length is the total length of straight sections PLUS 5 feet (1.5m) for each 90 degree elbow and 2.5 feet (.75m) for each 45 degree elbow.
4. The top of the vent pipe should extend at least 2 feet (0.61m) above the highest point on the roof. Consideration should be made for anticipated snow depth. Install an Amerivent Americap or Metalbestos vent cap over the vent opening. Slope horizontal runs upward from the gas unit heater at least 1/4-inch per foot (21mm/m) minimum. Horizontal portions of the venting system shall be supported at minimum intervals of 4 feet (1.2m) (in Canada, support at 3 foot (1m) minimum intervals). (See Figures 13B, 15 and 17)
5. Avoid running vent pipe through unheated spaces. When this cannot be avoided, insulate the pipe to prevent condensation of moisture on the walls of the pipe.

Figure 13A - Category III Horizontal Venting Requirements Using Single Wall Vent Pipe

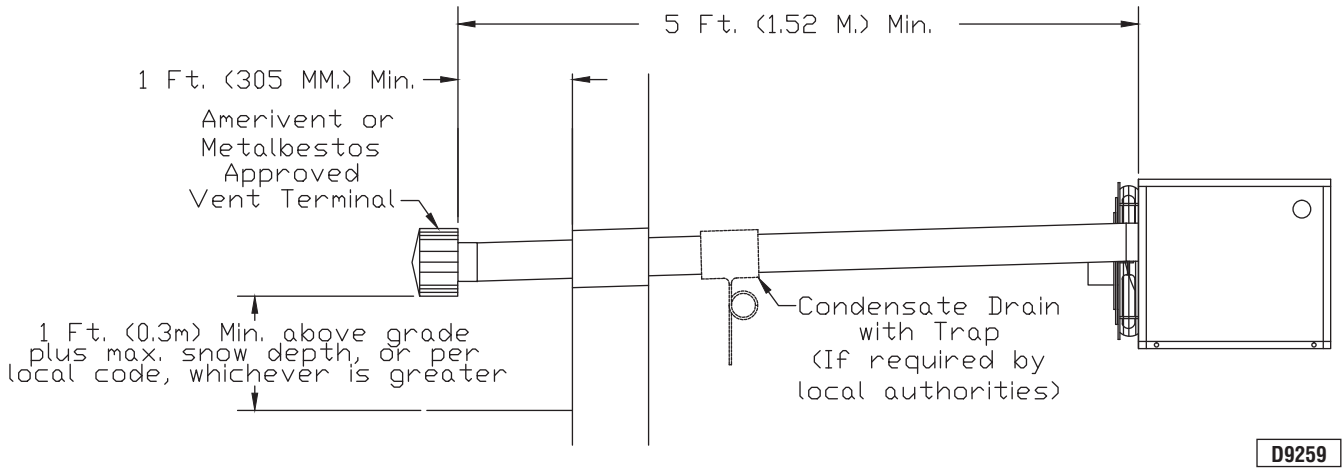
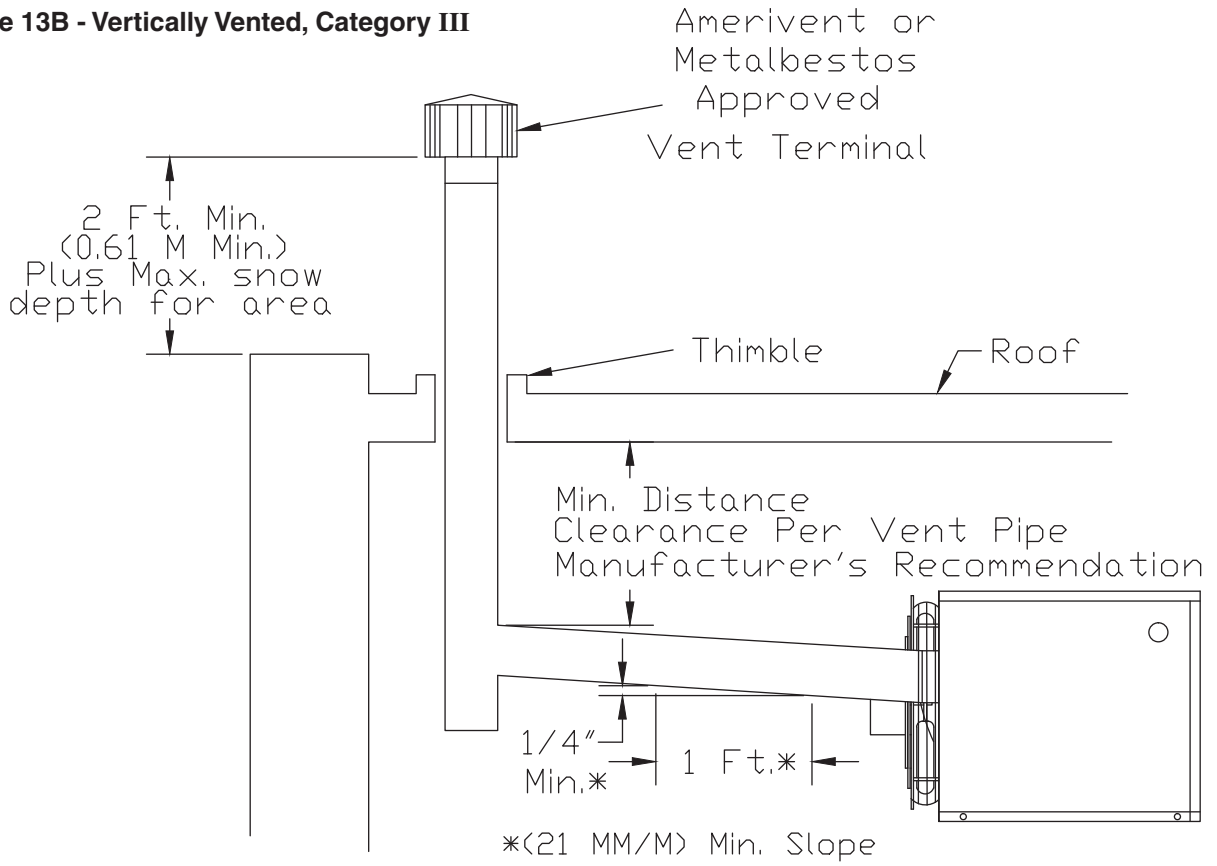

Figure 13B - Vertically Vented, Category III



D9258

VENTING (continued)

Figure 14

HORIZONTAL ARRANGEMENT SINGLE WALL VENT SYSTEM TO SINGLE WALL TERMINATION

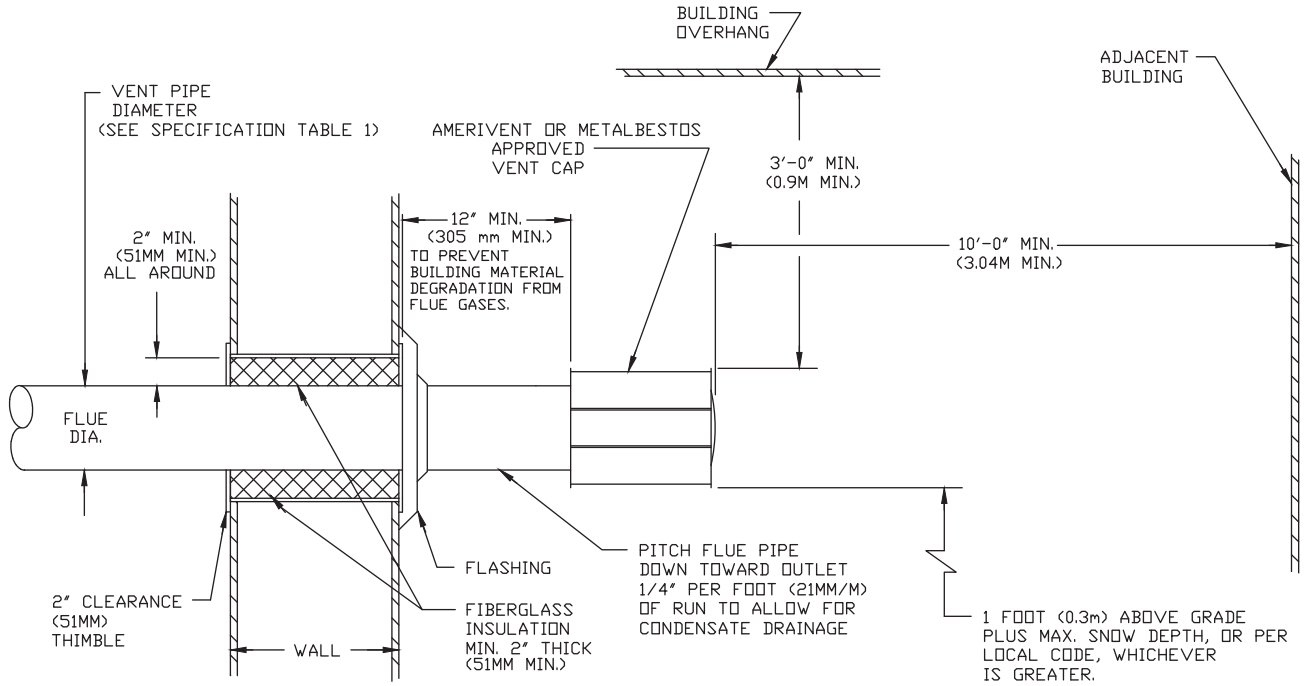

D9260

Figure 15

VERTICAL ARRANGEMENT SINGLE WALL VENT SYSTEM TO SINGLE WALL TERMINATION

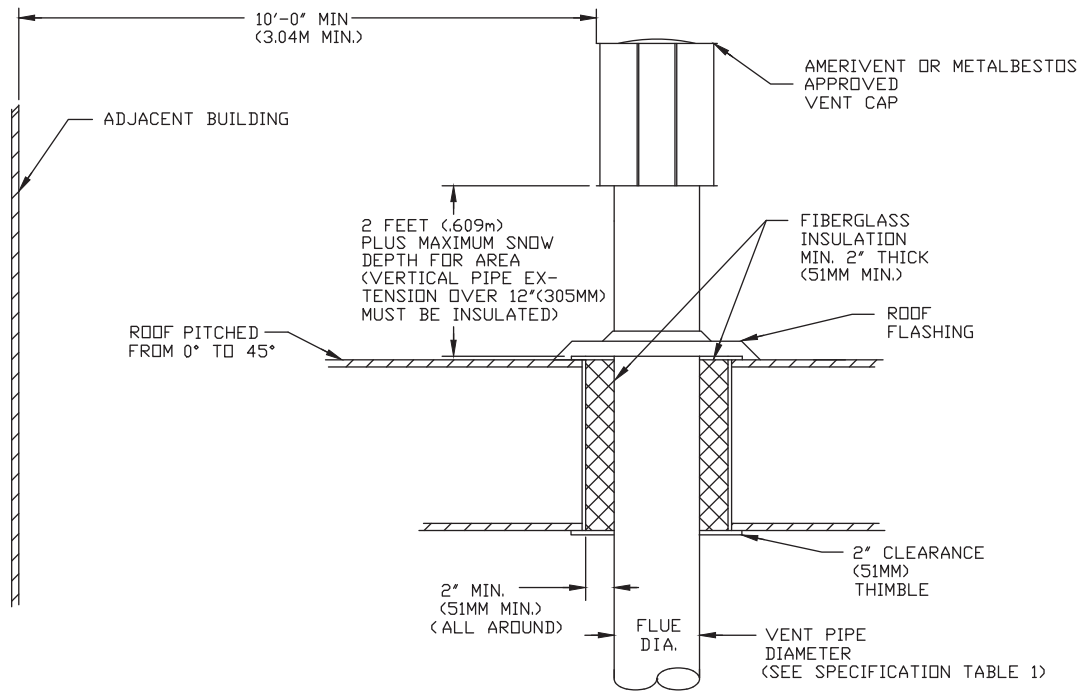

D9261

VENTING (continued)

Figure 16

HORIZONTAL ARRANGEMENT SINGLE WALL VENT SYSTEM TO DOUBLE WALL TERMINATION

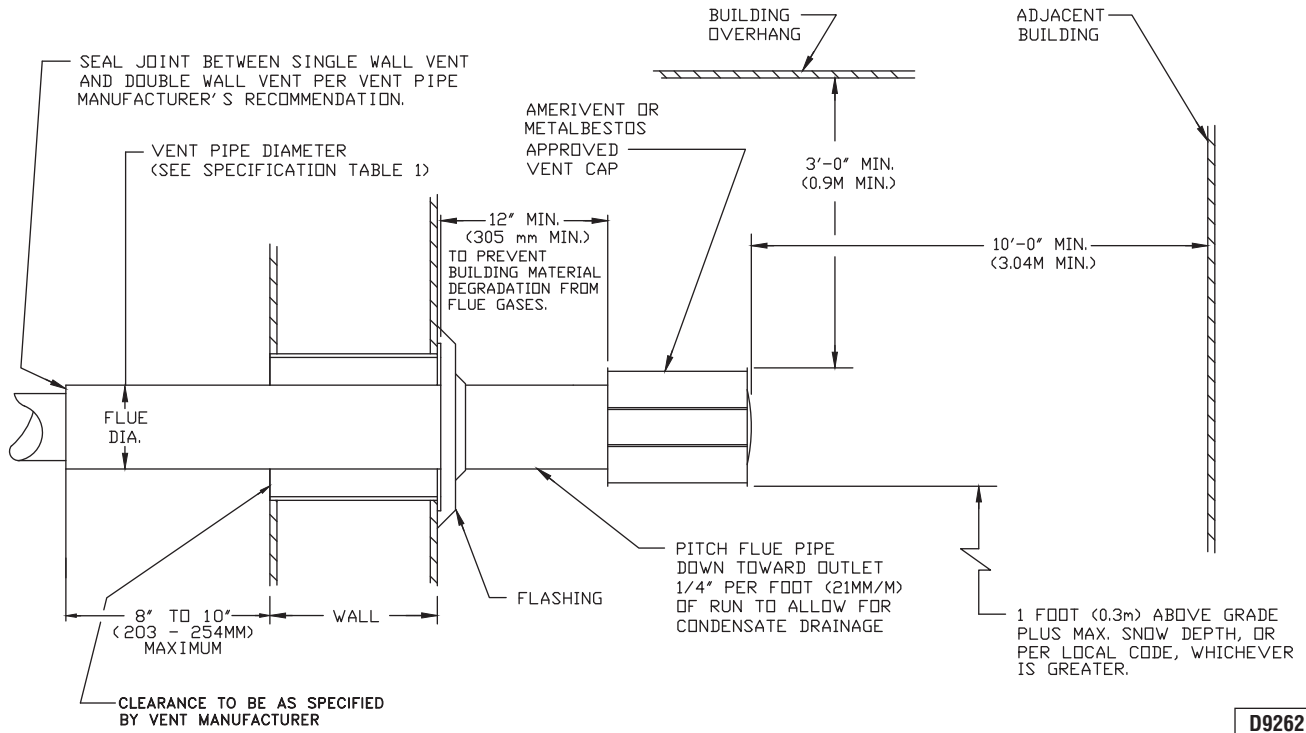
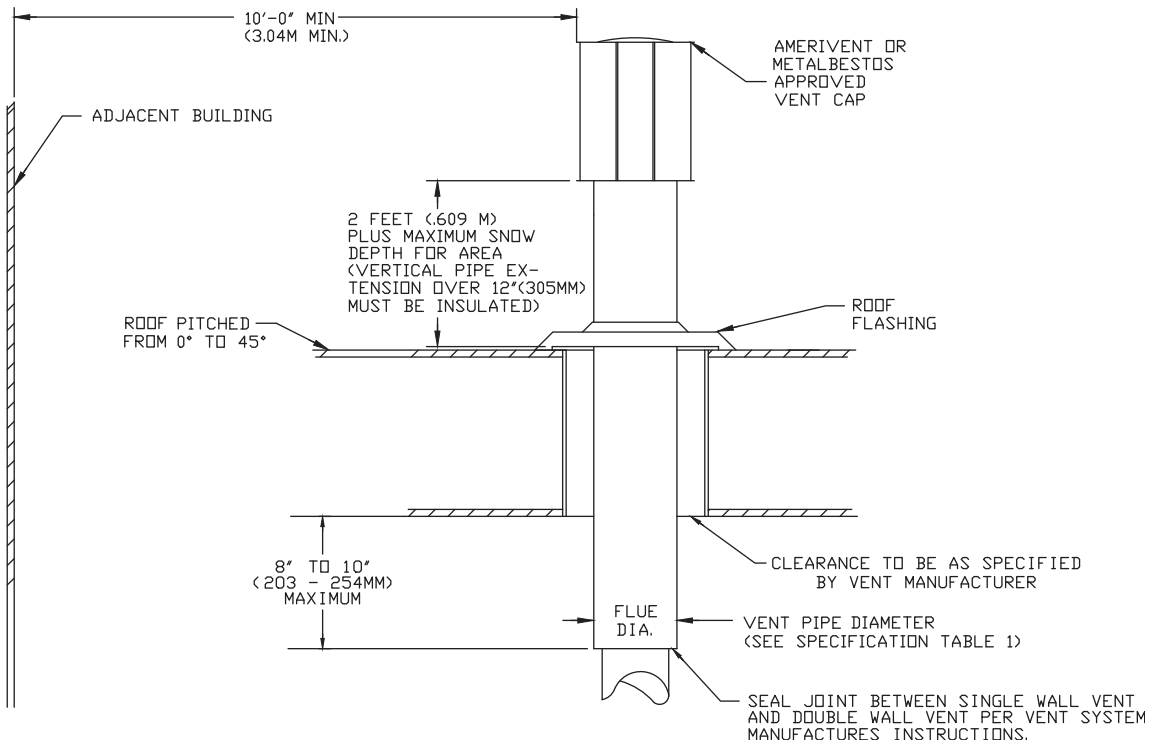

Figure 17

VERTICAL ARRANGEMENT SINGLE WALL VENT SYSTEM TO DOUBLE WALL TERMINATION



SEPARATED COMBUSTION

INSTALLATION - VENTING – CATEGORY III

NOTICE: Every Separated Combustion unit to be installed MUST use the Factory available Combustion Air Inlet Kit. If you do not have this kit, contact the manufacturer ASAP to obtain one prior to installation.

COMBUSTION AIR

▲ WARNING Never operate unit heaters without combustion air and flue gas piping in place or severe personal injury or death may occur!

▲ WARNING CARBON MONOXIDE!

Your venting system must not be blocked by any snow, snow drifts, or any foreign matter. Inspect your venting system to ensure adequate ventilation exists at all times! Failure to heed these warnings could result in Carbon Monoxide Poisoning (symptoms include grogginess, lethargy, inappropriate tiredness, or flu-like symptoms).

1. The combustion air system installation must be in accordance with the current edition of the National Fuel Gas Code-NFPA 54 or ANSI Z223.1 National Fuel Gas Code. In Canada, installation must be in accordance with CSA-B149.1 "Installation Code for Natural Gas Burning Appliances and Equipment" and CSA-B149.2 "Installation Code for Propane Burning Appliances and Equipment".
2. The combustion air inlet box, inlet air screen, deflector disk, and vent terminal provided with the unit heater must be installed at the termination point of the combustion air/vent system. See Figures 18, 19, 20 and 21 and Table 6.
3. Each unit heater MUST have its own combustion air system. It MUST NOT be connected to other air intake systems.
4. Combustion air intake duct may be PVC, CPVC, Type B vent, single wall, double wall or other material approved by local code authority. Never use duct size other than diameter stated in Table 1.
5. Long runs of single or double wall combustion air piping passing through an unheated space may require insulating if condensation becomes noticeable.
6. The combustion air system must be installed to prevent collection of condensate. Pitch horizontal pipes downward 1/4 inch per foot toward the inlet cap to facilitate drainage. Vertical combustion air pipes should be piped as depicted in Figure 19.
7. The equivalent length of the combustion air system must not be less than 5 feet (1.5m) and must not exceed 30 feet (9m). Equivalent length equals the total length of straight pipe plus 5 feet (1.5m) for each 90° elbow and 2.5 feet (0.76m) for each 45° elbow.

NOTICE: For optimum performance keep the combustion air system as straight as possible.

8. Each slip joint must be secured with at least three corrosion resistant screws. Two full turns of 3M #425 Aluminum Foil Tape or its equivalent must then be used to seal each joint. General Electric RTV-108, Dow-Corning RTV-732 or an equivalent silicone sealant with a temperature rating of 500°F may be used instead of the tape.
9. For horizontal combustion air systems longer than 5 feet (1.5m), the system must be supported from overhead building structures at 4 foot (1.2m) intervals in the U.S. and at 3 foot (0.91m) intervals in Canada.

EXHAUST VENTING

▲ WARNING Never operate unit heaters without combustion air and flue gas piping in place or severe personal injury or death may occur!

1. Vent system installation must be in accordance with the current National Fuel Gas Code-NFPA 54 or ANSI Z223.1 National Fuel Gas Code. In Canada installation must be in accordance with CSA-B149.1 "Installation Code for Natural Gas Burning Appliances and Equipment" and CSA-B149.2. "Installation Code for Propane Burning Appliances and Equipment".
2. **The Combustion Air Inlet Kit (which includes a combustion air inlet box, air inlet screen, deflector disk, vent terminal and inlet air collar) available for the heater by the manufacturer MUST be installed at the termination point of the combustion air/vent system.** See Figures 18, 19, 20 and 21 and Table 6.
3. Each unit heater MUST have its own vent system. It MUST NOT be connected to other vent systems or to a chimney.

SEPARATED COMBUSTION

VENTING (continued)

4. Use UL 1738 listed single or double wall pipe for the vent system. For installations in Canada, use corrosion resistant and gas-tight, listed vent pipe conforming with local building codes, or in the absence of local building codes, with current CSA-B149.1, Installation Codes for Natural Gas Burning Appliances and Equipment or CSA-B149.2, Installation Codes for Propane Gas Burning Appliances and Equipment. For residential installations in the United States, vent pipe approved for Category III appliances must be used between the appliance and the combustion air inlet box.
7. The equivalent length of the vent system must not be less than 5 feet (1.5m) and must not exceed 30 feet (9m). The equivalent length equals the total length of straight pipe plus 5 feet (1.5m) for each 90 degree elbow and 2.5 feet (0.76m) for each 45 degree elbow.
8. For horizontal vent systems longer than 5 feet (1.5m), the system must be supported from overhead building structures at 4 foot (1.2m) intervals in the U.S. and at 3 foot (0.91m) intervals in Canada.
9. The exhaust vent system must remain at a minimum distance of 1 inch (25mm) from all combustible materials. Any part of the vent system that passes through a combustible material must be properly insulated.

▲ WARNING Never use pipe other than diameter stated in Table 1. Never use PVC, ABS or any other non-metallic pipe for venting! To do so may result in serious damage to the unit and or severe personal injury or death!

5. Any run of single or double wall vent pipe passing through an unheated space must be insulated with an insulation suitable to 550° F.
6. The vent system must be installed to prevent collection of condensate. Pitch horizontal pipes downward 1/4 inch per foot (21mm per meter) toward the vent cap to facilitate drainage. Vertical vent pipes should be piped as depicted in Figure 19.

NOTICE: Increasing the clearance distances may be necessary if there is a possibility of distortion or discoloration of adjacent materials.

Figure 18 - Combustion Air Inlet Box

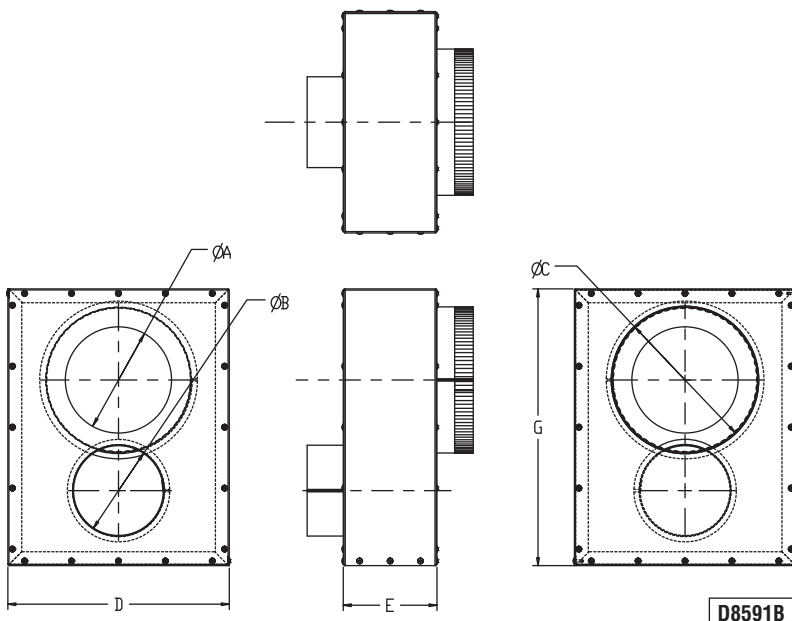
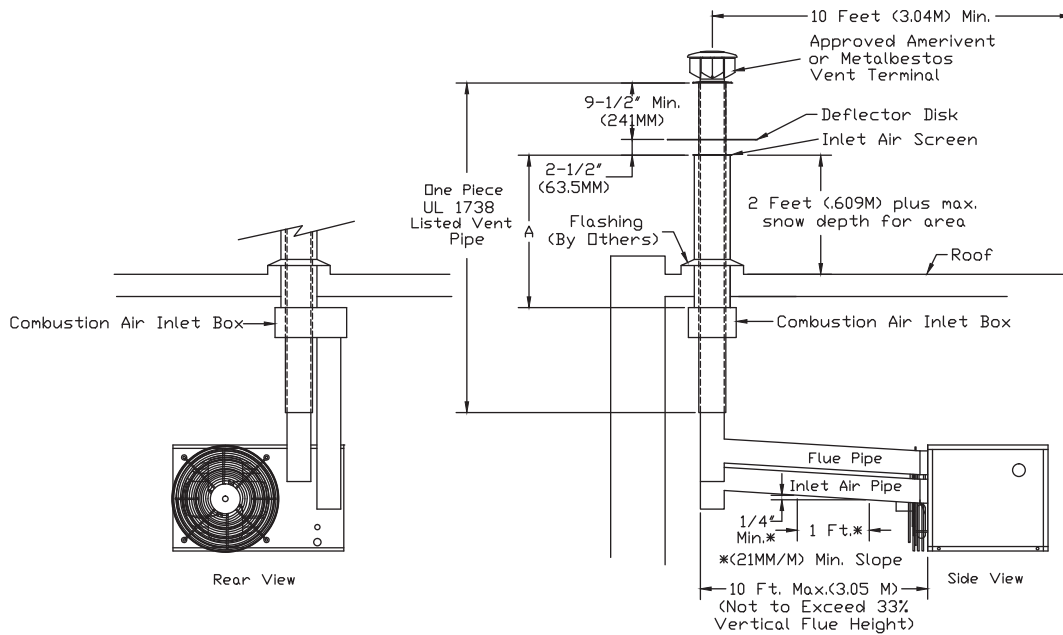

Table 6 - Combustion Air Inlet Box Dimensions

Unit Size	Dimensions - Inches (Nominal)					
	A	B	C	D	E	G
Combustion Air Inlet Kit Number AS-X7-4						
30	5-1/4	4	7	9	5	13
45						
60						
75						
Combustion Air Inlet Kit Number AS-X7-5						
90	6-1/4	5	9	12	5	16
105						
120						

Figure 19 - Vertical Intake/Vent Installation



D9264

Figure 20 - Horizontal Intake/Vent Installation

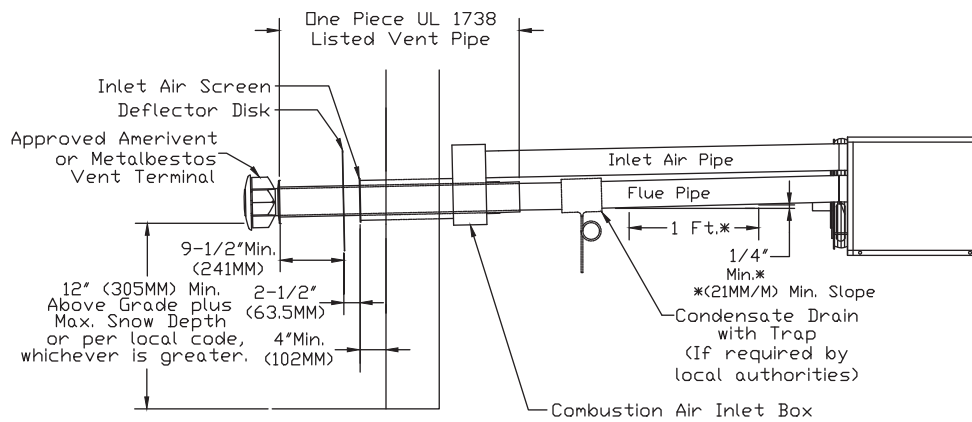

D9265

Figure 21 - Horizontal Intake/Vent Installation

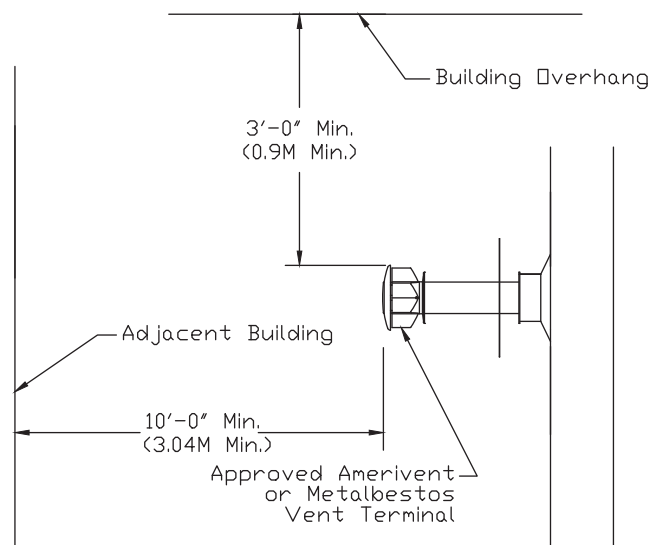

D9266

SEPARATED COMBUSTION

VENTING (continued)

NOTICE: Every Separated Combustion unit to be installed MUST use the Factory available Combustion Air Inlet Kit. See installation instructions included with kit for complete list of instructions. If you do not have this kit, contact the manufacturer ASAP to obtain one prior to installation.

AIR INLET COLLAR

Remove screen and mounting plate from air inlet on rear panel of unit by removing 4 screws. Secure inlet collar and gasket to inlet opening re-using the 4 screws removed in previous step.

EXHAUST AIR COLLAR

Secure 5-4 inch reducer to flue collar on rear panel of unit sizes 090, 105 and 120. Seal per exhaust venting instructions.

VERTICAL TERMINATION

Select location on roof for vent terminal, ensuring adequate space inside the building/structure for combustion air inlet box. Terminal must be at least 10 feet (3.04m) from any wall or adjoining building. See Figure 19 and Table 5.

Cut a hole through the roof for combustion air pipe. Combustion air inlet box is to be suspended from the underside of the roof using suitable brackets (field supplied). Before mounting box, cut a length of 7 inch (178mm) (sizes 030-075) or 9 inch (229mm) (sizes 090-120) pipe so that dimension A, Figure 19, is equal to the dimension from the top of the box to the roof surface plus 2 feet (0.61m), plus expected snow depth, whichever is greater. Fasten pipe to combustion air inlet connection of combustion air inlet box and seal joint. Insert pipe through roof and fasten vent box in place. Flash and/or caulk pipe to roof. Install inlet air screen assembly and fasten to pipe with screws.

Insert a 5 foot length of UL 1738 listed vent pipe through the combustion air inlet box opening (detail A, Figure 18) with the "UP" arrow pointing up. Position the pipe to extend 12 inches (305mm) beyond the inlet air screen. Seal the space between the vent pipe and opening of the combustion air inlet box using high temperature silicone sealant. Install deflector disk on UL 1738 listed metal vent pipe 2-1/2 inches above inlet air screen and fasten with screws. Seal joint between deflector disk and pipe with silicone sealant. Install vent terminal on top of UL 1738 listed vent pipe, fasten with screws and seal joint.

Connect flue pipe and combustion air pipe from combustion air inlet box to unit. Joint between double wall vent pipe and single wall vent pipe must be sealed with high temperature silicone sealant. Collars on unit and on combustion air inlet box are sized so that crimped ends of combustion air pipes go toward the unit and crimped ends of flue pipes go away from the unit.

HORIZONTAL TERMINATION

Select a location on outside wall for vent terminal. In most applications, the terminal should be on level with the flue outlet of the unit less a 1/4 inch per foot pitch for condensate drainage toward the outside of the building. See Figure 20 and Table 5 for terminal clearance.

Cut a hole through the wall for a 7 inch (178mm) sizes (030-075) or 9 inch (229mm) sizes (090-120) combustion air pipe. Install thimble if required by local codes or type of wall construction.

Combustion air inlet box may be fastened directly to wall or spaced away from wall using suitable brackets (field supplied). Cut a length of pipe so that it will protrude 4 inches (102mm) through the wall when the box is mounted in position. Fasten pipe to box with sheet metal screws, using at least three screws per joint. Seal joint with high temperature silicone sealant.

Insert pipe through wall and fasten adapter box in place so that the pipe pitches downward 1/4 inch per foot (21mm/m) toward the outside. Flash and/or caulk pipe on outside wall. Install inlet air screen assembly and fasten to pipe with screws. Insert a continuous length of 4 inch (sizes 030-075) or 5 inch (sizes 090-120) UL 1738 listed vent pipe through the combustion air inlet box opening (detail A, Figure 18). Position the pipe to extend a minimum 12 inches (305mm) beyond the inlet air screen.

Seal the space between the vent pipe and opening of the combustion air inlet box using high temperature silicone sealant. Install deflector disk on UL 1738 listed metal vent pipe 2-1/2 inches (63.5mm) from inlet air screen and fasten with screws. Install vent terminal on end of UL 1738 listed vent pipe, fasten with screws and seal joint.

Connect flue pipe and combustion air pipe from combustion air inlet box to unit. Joint between double wall vent pipe and single wall vent pipe must be sealed with high temperature silicone sealant. Collars on unit and on combustion air inlet box are sized so that crimped ends of combustion air pipes go toward the unit and crimped ends of flue pipes go away from the unit.

OPERATION

POWER VENTED PROPELLER UNITS

DIRECT SPARK IGNITION

EXPLANATION OF CONTROLS:

1. Each Unit Heater comes equipped with a power vent system that consists of a power venter motor and blower, pressure switch, and sealed flue collector in place of the conventional draft diverter.
2. The power venter motor is energized by the room thermostat through the integrated control board when a demand for heat is sensed. The pressure switch measures the flow through the vent system and energizes the direct spark ignition system beginning the pre-purge timing when the flow is correct.

▲ WARNING The pressure switch **MUST NOT** be bypassed. The unit **MUST NOT** be fired unless the power venter is operating. An unsafe condition could result.

3. The direct ignition system consists of an ignition control module and a gas valve. When the pre-purge period ends, the spark ignition system is energized, and the gas valve opens to supply gas to the burner. When the thermostat is satisfied, the vent system is de-energized and the valve closes to stop the flow of gas to the unit.
4. The limit switch interrupts the flow of electric current to the control board, interrupting the flow of gas to the gas valve if the unit heater becomes overheated.
5. The flame roll-out switch interrupts the flow of electric current to the control board, interrupting the flow of gas to the unit heater in the event of sustained flame roll-out from the burner area. **If this switch trips, DETERMINE AND CORRECT THE CAUSE of the flame roll-out.**
6. Once the thermostat is satisfied, or the limit switch interrupts the flow of electric current to the control board, the unit will begin a post-purge period. When the post-purge period ends, the power venter motor is de-energized.
7. The fan operation is delayed 30 seconds once the thermostat is closed, and continues operation for 30 seconds after the thermostat opens. **The start-up fan delay must not exceed 30 seconds from a cold start.**

8. The wall thermostat, supplied optionally, is a temperature sensitive switch that operates the vent system and ignition system to control the temperature of the space being heated. The thermostat must be mounted on a vertical, vibration-free surface free from air currents and in accordance with the furnished instructions (also refer to Electrical Section).

START-UP (Also refer to lighting instruction plate equipped on the unit)

1. Open the manual gas valve in the gas supply line to the unit heater with union connection loose, purge air from the gas line. Tighten the union and check for leaks.

▲ WARNING Never use an open flame to detect gas leaks. Explosive conditions may exist which could result in personal injury or death.

2. Open the manual valve on the unit heater.
3. Turn ON the electrical power.
4. The unit should be under the control of the thermostat. Turn the thermostat to the highest point and determine that the power venter motor starts and the burner ignite. Turn the thermostat to the lowest point and determine that the power venter motor shuts off and the burner is extinguished.
5. Turn the thermostat to the desired position.
6. See Gas Input Rate and Adjustments sections.

SHUT DOWN

1. Turn the valve selector lever to the "OFF" position.
2. Turn off the electricity.
3. To relight, follow "start-up" instructions.

See Figure 22 through 28 for parts/identification.

Figure 22 - Direct Spark Ignition System

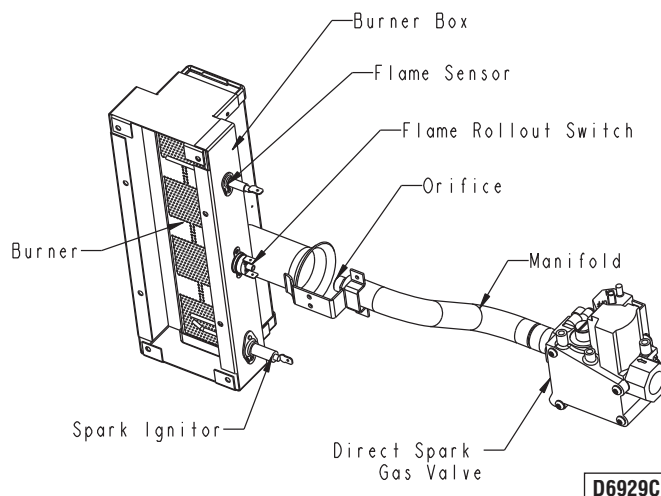

D6929C

PRIMARY AIR ADJUSTMENT

Primary air adjustment is made at the factory. No field adjustments are necessary.

GAS INPUT RATE

Check the gas input rate as follows (Refer to General Safety Information section for metric conversions).

▲ CAUTION Never overfire the unit heater, as this may cause unsatisfactory operation, or shorten the life of the heater.

1. Turn off all gas appliances that use gas through the same meter as the unit heater.
2. Turn the gas on to the unit heater.
3. Clock the time in seconds required to burn 1 cubic foot of gas by checking the gas meter.
4. Insert the time required to burn one cubic foot of gas into the following formula and compute the input rate.

$$\frac{3600 \text{ (Sec. per Hr.)} \times \text{BTU/Cu. Feet}}{\text{Time (Sec.)}} = \text{Input Rate}$$

For example:

Assume the BTU content of one cubic foot of gas is 1000, and that it takes 48 seconds to burn one cubic foot of gas.

$$\frac{3600 \times 1000}{48} = 75,000$$

NOTICE: If the computation exceeds, or is less than 95% of the gas BTU/hr. input rating (see Table 1), adjust the gas pressure.

Adjust the gas pressure as follows:

1. **NATURAL GAS:** Best results are obtained when the unit heater is operating at its full rated input with the manifold pressure of 3.5 inches WC (0.9 kPa). Adjustment of the pressure regulator is not normally necessary since it is preset at the factory. However, field adjustment may be made as follows:
 - a. Attach manometer at the pressure tap plug below the control outlet.
 - b. Remove the regulator adjustment screw cap, located on the combination gas valve.
 - c. With a small screwdriver, rotate the adjustment screw counterclockwise to decrease pressure, or clockwise to increase pressure.
 - d. Replace regulator adjustment screw cap.
2. **PROPANE GAS:** An exact manifold pressure of 10.0

inches W.C. (2.5 kPa) must be maintained for proper operation of the unit heater. If the unit is equipped with a pressure regulator on the combination gas valve, follow steps "a" through "d" above. If the unit is not so equipped, the propane gas supply system pressure must be regulated to attain this manifold operating pressure.

3. The adjusted manifold pressure should not vary more than 10% from pressure specified in Tables 7 & 8.

Table 7 - Main Burner Orifice Schedule*

* INPUT IN 1000 BTU	TYPE OF GAS	NATURAL	PROPANE	NUMBER OF BURNER ORIFICES
	HEATING VALUE	1050 BTU/Ft ³ (39.1 MJ/m ³)	2500 BTU/Ft ³ (93.1 MJ/m ³)	
	MANIFOLD PRESSURE	3.5 inches WC (0.87kPa)	10 inches WC (2.49 kPa)	
30	FT ³ /HR	28	12	1
	ORIFICE DRILL	38	52	
45	FT ³ /HR	42	18	1
	ORIFICE DRILL	31	48	
60	FT ³ /HR	56	24	1
	ORIFICE DRILL	27	43	
75	FT ³ /HR	70	30	1
	ORIFICE DRILL	20	40	
90	FT ³ /HR	84	36	1
	ORIFICE DRILL	16	36	
105	FT ³ /HR	98	42	1
	ORIFICE DRILL	11	32	
120	FT ³ /HR	112	48	1
	ORIFICE DRILL	6	3.1MM	

*This schedule is for units operating at normal altitudes of 2000 feet (610m) or less.

When installed in Canada, any references to deration at altitudes in excess of 2000 feet (610m) are to be ignored. At altitudes of 2000 to 4500 feet (610 to 1372m), the unit heaters must be field derated and be so marked in accordance with ETL certification. See Table 8 for USA and Canadian field deration information.

TUBULAR UNIT HEATER HIGH ALTITUDE DERATION

This Tubular Unit Heater has been manufactured utilizing standard burner orifices and a normal manifold pressure setting as per the specifications shown on your unit rating plate (refer to Tables 4, 7 and 8).

All unit deration must be done through field adjustments by a qualified technician (refer to Table 8). Once the proper adjustments are made in the field, attach label #J17-06459 to the unit, and record adjusted manifold pressure, altitude of the unit installation and the technician's name and date on the label using a permanent marker.

Table 8

High Altitude Deration - United States

Altitude		Manifold Pressure				BTU Output ¹
		Natural Gas ²		Liquid Propane ³		
Feet	Meters	Inches WC	Pa	Inches WC	Pa	Percentage
0-2,000	0-610	3.5	872	10	2,491	100%
2,001-3,000	611-915	3.2	797	9.2	2,292	96%
3,001-4,000	916-1,220	2.9	722	8.4	2,092	92%
4,001-5,000	1,221-1,525	2.7	673	7.7	1,918	88%
5,001-6,000	1,526-1,830	2.4	598	7	1,744	84%
6,001-7,000	1,831-2,135	2.2	548	6.4	1,594	80%
7,001-8,000	2,136-2,440	2	498	5.7	1,420	76%
8,001-9,000	2,441-2,745	1.8	448	5.1	1,270	72%
9,001-10,000	2,746-3,045	1.6	399	4.6	1,145	68%

- Notes:
1. Deration based on ANSI Z223.1 (NFPA 54).
 2. Table based on heating value of 1,050 BTU/Cu. ft. at sea level.
 3. Table based on heating value of 2,500 BTU/Cu. ft. at sea level.
 4. Consult local utility for actual heating value.

High Altitude Deration - Canada

Altitude		Manifold Pressure				BTU Output ¹
		Natural Gas ²		Liquid Propane ³		
Feet	Meters	Inches WC	Pa	Inches WC	Pa	Percentage
0-2,000	0-610	3.5	872	10	2,491	100%
2,001-3,000	611-915	3.2	797	9.2	2,292	96%
3,001-4,000	916-1,220	2.9	722	8.4	2,092	92%
4,001-4,500	1,221-1,371	2.8	697	7.9	1,968	90%

- Notes:
1. Deration based on CGA 2.17-M91
 2. Table based on heating value of 1,050 BTU/Cu. feet at sea level.
 3. Table based on heating value of 2,500 BTU/Cu. feet at sea level.
 4. Consult local utility for actual heating value.

MAINTENANCE

PERIODIC SERVICE

NOTICE: The heater and vent system should be checked once a year by a qualified technician.

All Maintenance/Service information should be recorded accordingly on the Inspection Sheet provided in this manual.

▲ WARNING Open all disconnect switches and disconnect all electrical and gas supplies and secure in that position before servicing unit. Failure to do so may result in personal injury or death from electrical shock.

▲ WARNING Gas tightness of the safety shut-off valves must be checked on at least an annual basis.

To check gas tightness of the safety shut-off valves, turn off the manual valve upstream of the appliance combination control. Remove the 3/32 hex head plug on the inlet side of the combination control and connect a manometer to that tapping. Turn the manual valve on to apply pressure to the combination control. Note the pressure reading on the manometer, then turn the valve off. A loss of pressure indicates a leak. If a leak is detected, use a soap solution to check all threaded connections. If no leak is found, combination control is faulty and must be replaced before putting appliance back in service.

Should maintenance be required, perform the following inspection and service routine:

1. Inspect the area near the unit to be sure that there is no combustible material located within the minimum clearance requirements listed in this manual.

▲ WARNING Under no circumstances should combustible material be located within the clearances specified in this manual. Failure to provide proper clearance could result in personal injury or equipment damage from fire.

2. Turn off the manual gas valve and electrical power to the unit heater.

3. Remove service access panel.
4. To clean or replace the burner, remove retainer from around manifold orifice, disconnect flame sensor and igniter from control board, remove burner assembly mounting screws. See Figure 22.
5. With the burner removed, wire brush the inside surfaces of the heat exchanger.
6. Remove any dirt, dust, or other foreign matter from the burners using a wire brush and/or compressed air. Ensure that all parts are unobstructed.
7. Reassemble the unit heater by replacing all parts in reverse order.
8. Complete the appropriate unit startup procedure as given in the "Operation" section of this manual. (See lighting instruction on the unit nameplate).
9. Check the burner adjustment.
10. Check all gas control valves and pipe connections for leaks.
11. Check the operation of the automatic gas valve by lowering the setting of the thermostat, stopping the operation of the gas unit heater. The gas valve should close tightly, completely extinguishing the flame on the burner.
12. Inspect and service motor/fan assembly. To maintain efficient air flow, inspect and clean the fan blades and guard to prevent buildup of foreign matter.
13. Check lubrication instructions on motor. If oiling is required, add 1 or 2 drops of electric motor oil as follows:
 - a. Light Duty - After three years or 25,000 hours of operation.
 - b. Average Duty - Annually after 3 years or 8,000 hours of operation.
 - c. Heavy Duty - Annually after one year or at least 1500 hours of operation.

▲ CAUTION Never over oil the motor or premature failure may occur!

14. Check and test the operational functions of all safety devices supplied with your unit.

Table 9 - Tubular Propeller Troubleshooting Guide

SYMPTOMS	POSSIBLE CAUSE(S)	CORRECTIVE ACTION
A. Flame pops back.	<ol style="list-style-type: none"> 1. Burner orifice incorrect. 2. Low manifold Pressure. 	<ol style="list-style-type: none"> 1. Check for proper orifice size. Refer to "Operation". 2. Test and reset manifold pressure.
B. Noisy Flame.	<ol style="list-style-type: none"> 1. Irregular orifice causing whistle or resonance. 2. Excessive gas input. 	<ol style="list-style-type: none"> 1. Replace orifice. 2. Test and reset manifold pressure.
C. Yellow tip flame (some yellow tipping on LP gas is permissible).	<ol style="list-style-type: none"> 1. Clogged burner. 2. Misaligned orifice. 3. Insufficient combustion air. 4. Possibly over fired. 	<ol style="list-style-type: none"> 1. Clean main burner ports. 2. Align manifold assembly. 3. Clean combustion air inlet openings. 4. Check gas input and manifold pressures.
D. Floating flame.	<ol style="list-style-type: none"> 1. Blocked venting. 2. Insufficient combustion air. 3. Blocked heat exchanger. 4. Air leak into combustion chamber, flue collector or draft hood. 	<ol style="list-style-type: none"> 1. Clean Flue. Refer to "Installation". 2. Clean combustion air inlet openings. 3. Clean heat exchanger. Refer to "Installation". 4. Determine cause and repair accordingly.
E. Gas odor. Shut off gas supply immediately!	<ol style="list-style-type: none"> 1. Gas pipe leak. 2. Leaking gas test port on valve. 3. Blocked heat exchanger. 4. Blocked draft hood. 5. Negative pressure in the building. 	<ol style="list-style-type: none"> 1. Inspect all gas piping and repair. 2. Check to ensure gas test ports are seated. 3. Clean heat exchanger/flue. 4. Clean flue collector. 5. See "Installation".
F. Delayed ignition.	<ol style="list-style-type: none"> 1. Improper ground. 2. Bad or broken spark cable. 3. Faulty control. 4. Manifold pressure set too low. 5. Main burner orifice dirty. 6. Improper venting. 	<ol style="list-style-type: none"> 1. Check grounding wires and spark bracket connections. 2. Inspect spark cable connections and cuts. 3. Check to ensure spark is energized after pre purge period. 4. Test and reset manifold pressure refer to "Operations". 5. Clean or replace orifice. 6. Refer to "Installation".
G. Failure to ignite.	<ol style="list-style-type: none"> 1. Gas supply is off. 2. No power supply to unit. 3. Thermostat not calling. 4. Defective high limit. 5. Defective drafter prove switch. 6. Loose wiring. 7. Improper ground. 8. Improper thermostat or transformer wiring. 9. Ignitor defective/damaged. 10. Misaligned ignitor. 11. Defective gas valve. 12. Blown fuse. 	<ol style="list-style-type: none"> 1. Open all manual valves "check for leaks". 2. Turn on power supply, check fuses and replace if bad. 3. Turn up thermostat, Check for 24v on terminals R and W1 on terminal strip. 4. Check switch for continuity if open with no heat present, replace. 5. Check switch operation to ensure switch closes after drafter purge period. If it does not make/check tubing connections/blockage. 6. Check all wiring per diagram. 7. Check all ground wires and connections. 8. Check both, for wiring according to diagram. 9. Replace ignitor. 10. Resecure ignitor bracket. 11. Check for 24V at gas valve terminals during trial for ignition period. If present with no manifold pressure. Replace valve. 12. Refer to symptom "Q".
H. Condensation.	<ol style="list-style-type: none"> 1. Improper venting. 2. Unit under fired. 3. Building too cold. 	<ol style="list-style-type: none"> 1. Refer to "Installation, Venting". 2. Check gas supply pressures to unit. Refer to "Installation". 3. Refer to "Installation".

Table 9 - Tubular Propeller Troubleshooting Guide (continued)

SYMPTOMS	POSSIBLE CAUSE(S)	CORRECTIVE ACTION
I. Burner will not shut off.	<ol style="list-style-type: none"> 1. Thermostat located incorrectly. 2. Improper thermostat wiring. 3. Shorted circuit. 4. Defective sticking gas valve. 5. Excessive gas supply pressure. 	<ol style="list-style-type: none"> 1. Relocate thermostat away from outside wall or drafts. 2. Check thermostat circuit for open and close on terminal strip on heater "R" and "W". 3. Check thermostat circuit for shorts "staples piercing wires". 4. Check for 24v on gas valve terminals when thermostat is not calling. 5. Refer to "Installation".
J. Rapid burner cycling.	<ol style="list-style-type: none"> 1. Loose electrical connections at thermostat or gas valve. 2. Excessive thermostat heat anticipator setting. 3. Unit cycling on high limit. 4. Poor thermostat location. 	<ol style="list-style-type: none"> 1. Tighten all electrical connections. 2. Adjust heat anticipator setting for longer cycles. Refer to "Electrical Connections". 3. Check for proper air supply across heat exchanger and proper gas supply. 4. Relocate thermostat.
K. Noisy power venter.	<ol style="list-style-type: none"> 1. Power venter wheel loose. 2. Power venter wheel is dirty. 3. Power venter wheel is rubbing on the housing. 	<ol style="list-style-type: none"> 1. Replace or tighten. 2. Clean power venter wheel. 3. Realign power venter wheel.
L. Fan will not run.	<ol style="list-style-type: none"> 1. Loose electrical connections. 2. Defective motor or overload. 3. Defective control board. 4. Blown fuse. 	<ol style="list-style-type: none"> 1. Check and tighten wires on fan circuit. 2. Test for 115v on terminal ACB Heat and "L2" if voltage is present replace motor. 3. Test for 115v on terminal ACB Heat and "L2" on the control board, if voltage is not present 45 seconds after trial for ignition replace board. 4. Replace fuse.
M. Fan motor turns on and off while burner is operating.	<ol style="list-style-type: none"> 1. Motor overload protection is tripping. 2. Loose wiring or connection. 3. Control board is defective. 	<ol style="list-style-type: none"> 1. Check motor amps against motor name plate, check voltage, replace if found defective. 2. Check for 115v between motor leads. 3. Check terminal ACB Heat for voltage if voltage not constant, replace board.
N. Fan will not stop.	<ol style="list-style-type: none"> 1. Control Board is in flame failure mode. 2. Fan improperly wired. 3. Defective board. 	<ol style="list-style-type: none"> 1. Turn 115v power off to the unit, wait 10 seconds and reapply voltage to the unit. 2. Check wiring of fan circuit to wiring diagram. 3. If unit is not calling for heat and board is not in a flash code mode, replace board.
O. Not enough heat.	<ol style="list-style-type: none"> 1. Incorrect gas input. 2. Heater undersized. 3. Thermostat malfunction. 4. Heater cycling on limit. 5. Incorrect orifice size. 	<ol style="list-style-type: none"> 1. Refer to "Operation". 2. Is the heater output sized correctly for heat loss of the space. Has the space been enlarged? 3. Check thermostat circuit, 24v on terminals "R" and "W" on terminal strip. 4. Check air movement across heat exchanger. Check voltage and amps at the fan motor. Check gas input to ensure unit is not over fired. Check heat exchanger to ensure unit is not dirty. 5. Check orifice size, replace if undersized.
P. Too much heat.	<ol style="list-style-type: none"> 1. Unit is over fired. 2. Thermostat malfunction. 3. Heater runs continuously. 	<ol style="list-style-type: none"> 1. Refer to "Operation". Check orifice size. If too big replace. 2. Check thermostat for operation, to ensure circuit open and closes. 3. Check wiring per diagram; check operation at the gas valve, look for a short in thermostat circuit.
Q. Blown fuse.	<ol style="list-style-type: none"> 1. Electrical short. 2. Improper ground. 3. Defective gas valve. 	<ol style="list-style-type: none"> 1. Refer to wiring diagram. 2. Check grounding wires. 3. Replace.

Table 9 - Tubular Propeller Troubleshooting Guide

SYMPTOMS	POSSIBLE CAUSE(S)	CORRECTIVE ACTION
R. Cold air is delivered during heater operation.	1. Incorrect manifold pressure or input.	1. Refer to "Operation".
S. High limit tripping.	1. Unit is over fired. 2. Air flow is low. 3. Defective switch. 4. Defective control board.	1. Burner orifice may be too large, verify and replace. 2. Check for proper voltage, ensure fan blade is correctly positioned 1/3 inside venturi. 3. Check operation of switch, did the switch open when unit is running or is the switch open during start-up. 4. Check for 24v on line side of the high limit. Constant voltage should be recorded if not control board is suspect. Check flash code.
T. Power venter will not run.	1. Loose wiring or connections. 2. Motor overload is tripped or bad motor. 3. Bad control board.	1. Check all wiring in the power vent circuit to ensure good connection, including "Neutral". 2. Check for 115v between motor leads and check amp draw of motor. Replace if needed. 3. Check for continuous 115v on terminal "CBM Blower" and neutral during call for heat. If not present and all checks are normal, replace.
U. Power venter turns on and off during operation.	1. Power venter improperly wired. 2. Motor overload cycling or defective motor. 3. Defective control board.	1. Check power venter circuit per wiring diagram. 2. Check motor voltage and amp draw to motor name plate, replace if motor found defective. 3. Check for continuous 115v on terminal "CMB Blower" during call for heat, replace board if found defective.
V. Power venter will not stop.	1. Power venter improperly wired. 2. Main burner did not light on call for heat. 3. Defective control board. 4. Loss of pressure. Pressure switch not made.	1. Check power venter circuit per wiring diagram. 2. Heater is in lockout mode check flash code table for problem. 3. No flash codes present along with no call for heat, replace control board. 4. Check venting for blockage. Check tubing for blockage or hole. Check spud for blockage.

Table 10A - Troubleshooting with LED Indicator Assistance for UT Control Board

▲ WARNING

Line voltage power can cause product damage, severe injury or death. Only a trained experienced service technician should perform this troubleshooting.

1. Check the system thermostat to make sure it is calling for heat. (Do not cycle the thermostat on and off at this time.)
2. Remove the access panel. Do not interrupt power to the control board by opening any electrically interlocked panels.
3. Observe the LED indicator on the control board (a green LED labeled "OK" indicates system faults); check and repair system as noted in the chart to the right.

***NOTICE: Air flow proving switch and power venter hose barbs must be free of any dust or debris at all times. Periodically check these openings and/or if any problems occur.**

LED STATUS	INDICATES	CHECK/REPAIR
Slow Flash	Control OK, no call for heat.	Not Applicable
Fast Flash	Control OK, call for heat present.	Not Applicable
Steady Off	Internal control fault, or no power.	<ol style="list-style-type: none"> 1. Line voltage on terminals 120 and C on transformer. 2. Low voltage (24V) on terminals 24 and C on transformer. 3. 5 Amp fuse on circuit board.
Steady On	Control internal failure or bad ground.	<ol style="list-style-type: none"> 1. Common side of transformer grounded to chassis. 2. Loose spark ignitor.
2 Flashes	In lockout from failed ignitions or flame losses.	<ol style="list-style-type: none"> 1. Gas supply off or gas supply pressure too low. 2. Flame sense rod contaminated or loose wire. 3. Gas valve switch is off or wires are not connected. 4. Broken or cracked porcelain on flame probe or spark ignitor.
3 Flashes	Pressure Switch open with inducer on or closed with inducer off.	<ol style="list-style-type: none"> 1. Obstructions or restrictions in appliance air intake or flue outlet are preventing proper combustion airflow. *2. Moisture or debris in tubing that connects pressure switch and draft inducer. 3. Airflow switch jumpered or miswired.
4 Flashes	Limit or rollout switch is open.	<ol style="list-style-type: none"> 1. Open manual reset rollout switch. 2. Gas pressure too high, over fire condition. 3. Incorrect airflow due to blockage or motor not operating.
5 Flashes	Flame sensed while gas valve is off.	<ol style="list-style-type: none"> 1. Flame probe miswired or shortened.
6 Flashes	On-board microprocessors disagree.	<ol style="list-style-type: none"> 1. Thermostat is interfering with control board.

Table 10B - Troubleshooting with LED Indicator Assistance for Honeywell Control Board

PATTERN	STATUS	CHECK/REPAIR
Short Flash	Control powered (without call for Heat)	Not Applicable
Heartbeat	Call for Heat: normal operations	Not Applicable
2	Pressure Switch failed closed	<ol style="list-style-type: none"> 1. Check pressure switch to see if open to start, if not replace switch. 2. Air flow switch jumpered. Remove jumper and check operation.
3	Pressure Switch failed open	<ol style="list-style-type: none"> 1. Look for obstruction or restrictions in appliance air intake or flue outlet that are preventing proper combustion airflow. 2. Moisture or debris in tube that connects pressure switch and draft inducer. 3. Check spud on power venter housing. Make sure it is clear.
4	Limit circuit open	<ol style="list-style-type: none"> 1. Open manual reset rollout switch. 2. Gas pressure is too high, over fired condition. 3. Incorrect airflow due to blockage or fan motor not operating.
5	Flame sensed out of sequence - flame still present	<ol style="list-style-type: none"> 1. Flame probe miswired or shorted.
6+1	Softlockout: Failed to light in four ignition trials	<ol style="list-style-type: none"> 1. Gas supply off or gas pressure too low. 2. Flame sense rod contaminated or loose wire. 3. Gas valve switch is off or wires are not connected. 4. Broken or cracked porcelain on spark ignitor allowing spark to jump to ground and not between end of probes.
6+2	Softlockout: Limit circuit opened during run (recycle counter at its maximum)	<ol style="list-style-type: none"> 1. Open manual reset rollout switch. 2. Gas pressure too high, over fired condition causing high limit to open. 3. Incorrect airflow due to blockage or fan motor not operating.
6+3	Softlockout: Pressure Switch opened during run; did not reclose within 2 seconds (flame lost and recycle at its maximum)	<ol style="list-style-type: none"> 1. Check pressure from drafter and see if it reads above set point on pressure switch. Replace bad pressure switch.
6+4	Softlockout: Flame failed during run (recycle at its maximum)	<ol style="list-style-type: none"> 1. Check sensor wire and make sure it is connected properly.
6+5	Flame sensed while out of sequence and is now gone	
7+1	Lockout: Bad fuse detected.	<ol style="list-style-type: none"> 1. Check for short. If no short replace fuse and start unit. 2. If no short is found, check gas valve for possible over amp. condition. Replace gas valve.
7+2	Lockout: Low voltage on 24VAC input	<ol style="list-style-type: none"> 1. Check transformer for proper voltage. Replace transformer if not correct.
7+4	Lockout: Flame Rod shorted to ground or there is a big leakage from flame rod to ground	<ol style="list-style-type: none"> 1. Switch off power and check flame rod wiring.
7+5	Lockout: Gas Valve fault	<ol style="list-style-type: none"> 1. Turn unit off and back on. If fault code flashes again check gas valve for problem. If problem found replace gas valve.
7+6	Lockout: Internal Hardware error detected	<ol style="list-style-type: none"> 1. Reset board. If code flashes again replace board.

IDENTIFICATION OF PARTS TUBULAR 30-120 MBH UNIT SIZES

Figure 23

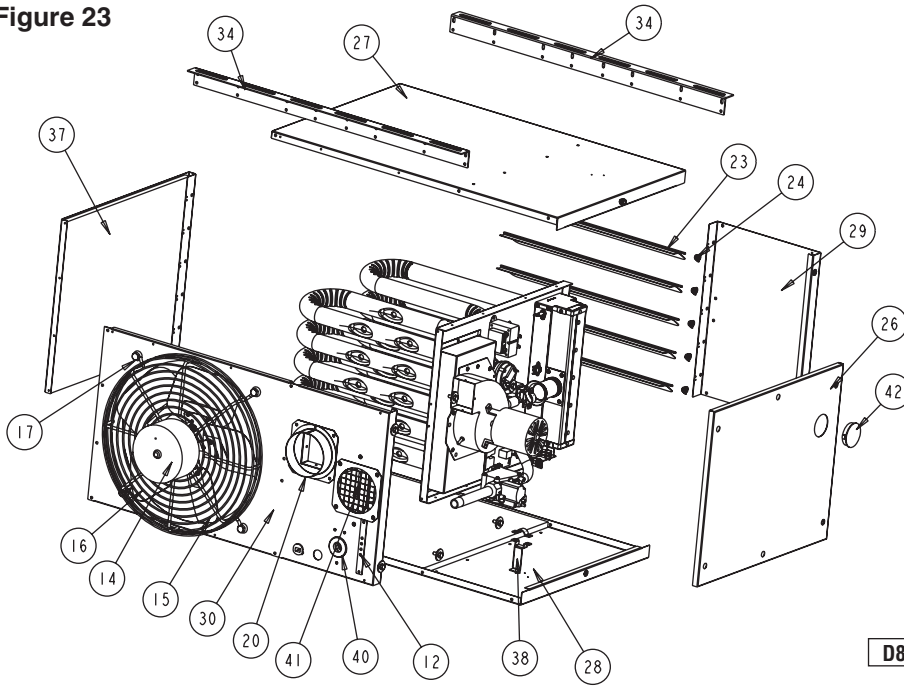

D8600

Figure 24

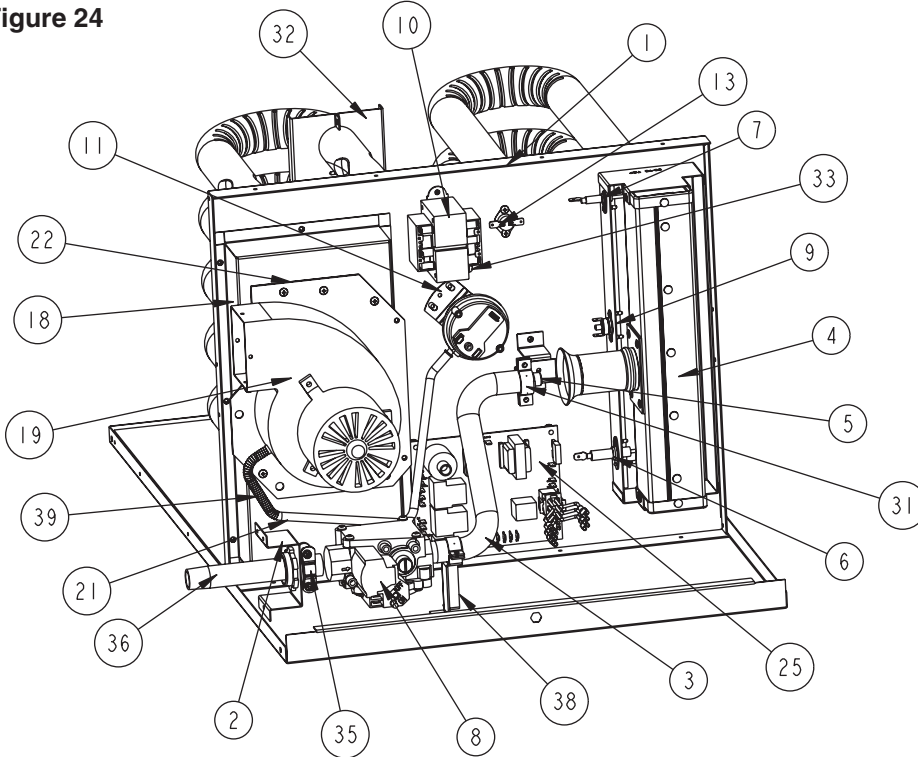

D6931B

Item No.	ItemDescription
1	Vestible Panel/Tube Assembly (Heat Exchanger)
2	Bracket/Gas Train
3	Manifold
4	Burner Assembly
5	*Standard Orifice Natural Gas or Propane (LP) Gas
6	Spark Ignitor
7	Flame Sensor
8	Gas Valve Natural or Propane (LP) Gas
9	Manual Rollout Safety Switch
10	Transformer, 50 VA, 115/24
11	Air Pressure Switch
12	Terminal Block Plate
13	High Limit Switch
14	Fan Motor
15	OSHA Fan Guard
16	Standard Fan
17	Fan/Guard/Motor Mount Hardware Kit
18	**Flue Collector
19	Power Venter (Drafter) Assembly
20	Flue Collar Assembly
21	Vinyl Tubing (Pressure Switch)
22	Power Venter Mounting Plate
23	Louver
24	Louver Spring
25	Control Board
26	Access Panel
27	Top Jacket Panel w/Insulation
28	Bottom Jacket Panel w/Insulation
29	Front Jacket Panel
30	Rear Jacket Panel
31	Bracket, Manifold
32	Tube Support Bracket
33	Green Ground Screw
34	Hanger Bracket
35	Manifold Clamp
36	Pipe Nipple
37	Left Side Panel
38	Manifold Support Bracket Kit
39	Spring
40	Grommet
41	Inlet Screen Assembly
42	Burner Box View Port

* The orifice shown are for units operating at normal altitudes of 0 to 2000 feet (610m).

** When replacing a flue collector, make sure that the flue collector box is sealed completely with factory supplied gasket.

IDENTIFICATION OF PARTS TUBULAR 30-120 MBH UNIT SIZES

Figure 25 - Propeller Parts

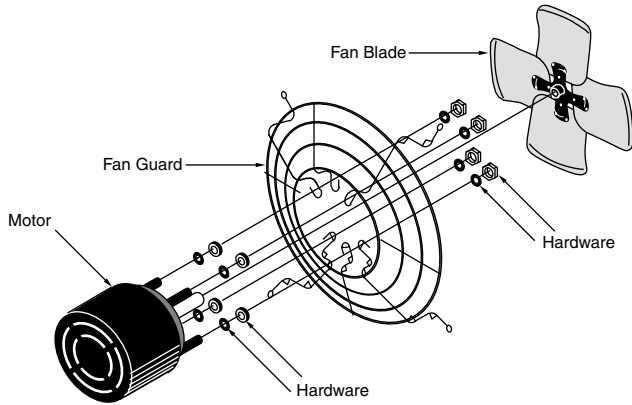

D4430

NOTE: No rubber grommets are supplied with the 30 and 45 unit sizes.

Figure 26 - Component Parts

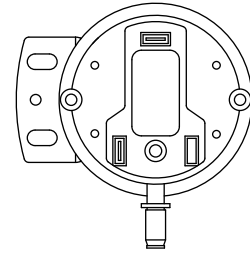

Pressure Switch

D03339

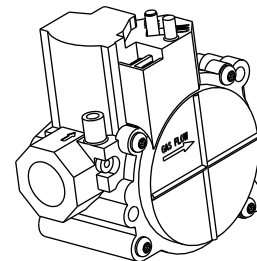

Gas Valve

D6963

Figure 27 - Internal Furnace Components

Unit Size	Tube Quantity
30 MBH	2
45 MBH	3
60 MBH	4
75 MBH	5
90 MBH	6
105 MBH	7
120 MBH	8

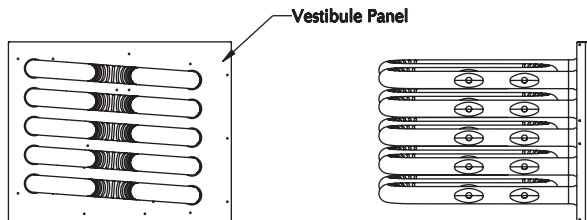
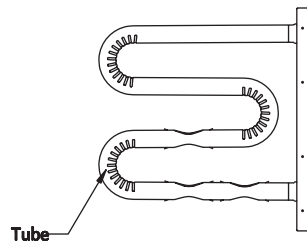

Heat Exchanger Assembly

D4809C

Figure 28 - Power Venter Assembly

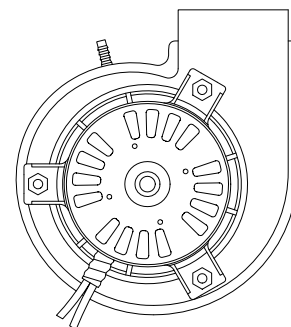
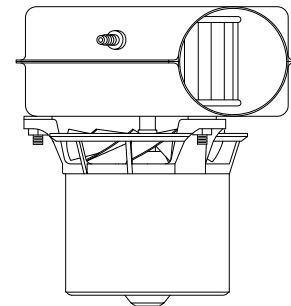

D4810

HOW TO ORDER REPLACEMENT PARTS

Please send the following information to your local representative: if further assistance is needed, contact the manufacturer's customer service department.

- Unit Number
- Serial Number
- Part Description and Number as shown in Replacement parts Catalog

LIMITED WARRANTY Power Vented Tubular Propeller Unit Heaters

1. The "Manufacturer" warrants to the original owner at original installation site that the above model Gas-Fired Heater ("the Product") will be free from defects in material or workmanship for (1) year from the date of shipment from the factory, or one and one-half (1-1/2) years from the date of manufacture, whichever occurs first. The Manufacturer further warrants that the complete heat exchanger, flue collector and burners be free from defects in material or workmanship for a period of ten (10) years from the date of manufacture. If upon examination by the Manufacturer the Product is shown to have a defect in material or workmanship during the warranty period, the manufacturer will repair or replace, at its option, that part of the Product which is shown to be defective.
2. This limited warranty does not apply:
 - a. if the product has been subjected to misuse or neglect, has been accidentally or intentionally damaged, has not been installed, maintained, or operated in accordance with furnished written instructions, or has been altered or modified in any way by any unauthorized person.
 - b. to any expenses, including labor or material, incurred during removal or reinstallation of the Product
 - c. to any damage due to corrosion by chemicals, including halogenated hydrocarbons, precipitated in the air
 - d. to any workmanship of the installer of the Product
3. This limited warranty is conditional upon:
 - a. advising the installing contractor, who in turn notify the distributor or manufacturer
 - b. shipment to the Manufacturer of that part of the Product thought to be defective. Goods can only be returned with prior written approval of the Manufacturer. All returns must be freight prepaid.
 - c. determination in the reasonable opinion of the Manufacturer that there exists a defect in material or workmanship
4. Repair or replacement of any part under this Limited Warranty shall not extend the duration of the warranty with respect to such repaired or replaced part beyond the stated warranty period.
5. **THIS LIMITED WARRANTY IS IN LIEU OF ALL WARRANTIES, EITHER EXPRESS OR IMPLIED, AND ALL SUCH OTHER WARRANTIES, INCLUDING WITHOUT LIMITATION IMPLIED WARRANTIES OF MERCHANTABILITY OR FITNESS FOR A PARTICULAR PURPOSE, ARE HEREBY DISCLAIMED AND EXCLUDED FROM THIS LIMITED WARRANTY. IN NO EVENT SHALL THE MANUFACTURER BE LIABLE IN ANY WAY FOR ANY CONSEQUENTIAL, SPECIAL, OR INCIDENTAL DAMAGES OF ANY NATURE WHATSOEVER, OR FOR ANY AMOUNTS IN EXCESS OF THE SELLING PRICE OF THE PRODUCT OR ANY PARTS THEREOF FOUND TO BE DEFECTIVE. THIS LIMITED WARRANTY GIVES THE ORIGINAL OWNER OF THE PRODUCT SPECIFIC LEGAL RIGHTS. YOU MAY ALSO HAVE OTHER RIGHTS WHICH MAY VARY BY JURISDICTION.**

In the interest of product improvement, we reserve the right to make changes without notice.

LOW PROFILE TUBULAR PROPELLER UNIT NUMBER DESCRIPTION

<i>Digit</i>	G	X	X	X	1	2	3	4	5	6	7	8	9	10	11	12	13	14	15	+	
<i>Item</i>	Prefix				UT	CA			FT	FM	GT	AL	GC	SV	MT	DL	AS				
	<small>(Internal use Only)</small>																				

Digit #1, 2 - Unit Type [UT]

GG - Low Profile Tubular Propeller

Note: Field conversion to Separated Combustion requires a Combustion Air Inlet Kit.

See Accessory Option X7-4 and X7-5 for proper unit selection.

Digit #3, 4, 5 - Capacity [CA]

030 - 30,000 BTU/HR

045 - 45,000 BTU/HR

060 - 60,000 BTU/HR

075 - 75,000 BTU/HR

090 - 90,000 BTU/HR

105 - 105,000 BTU/HR

120 - 120,000 BTU/HR

Digit #6 - Furnace Type [FT]

A - Right Side Access

Digit #7 - Furnace Material [FM]*

1 - Standard (Aluminized) Steel

2 - 409 Stainless Steel

**Heat Exchanger Tube Material Only.*

Digit #8 - Gas Type [GT]

N - Natural Gas

P - Propane Gas (LP)

Digit #9 - Altitude [AL]

S - 0-4,999 feet

T - 5,000-11,999 feet

Note: Installations over 2,000 feet require gas input deration in the field. Refer to unit installation instructions.

Digit #10 - Direct Spark Gas Control [GC]

A - Single Stage (Standard)

B - Two Stage (Capacities [CA] 060 through 120 only)

Digit #11 - Supply Voltage [SV]

1 - 115/1/60 **5** - 230/3/60

2 - 208/1/60 **6** - 460/3/60

3 - 230/1/60 **7** - 575/3/60

4 - 208/3/60 **Z** - Special

Note: Supply Voltages [SV] 2-7 include field mounted step down transformer.

Digit #12 - Motor Type [MT]

1 - Open Drip Proof (Standard)

2 - Totally Enclosed (Capacities [CA] 060 through 120 only)

Digit #13 - Development Level [DL]

C - Production Onset

Digit #14, 15+ - Accessories [AS]

FACTORY INSTALLED

S3 - 409 Stainless Steel Flue Collector

Z1 - Special

† FIELD INSTALLED (AS-____)

†Field Installed Accessories are not included in the Unit Number. All Field Installed Accessories are entered as a separate line item using the catalog number which utilizes "AS" as a prefix. i.e: A7 becomes AS-A7.

A7 - High Pressure Regulator

A7 - 1/2-1 Regulator for 0.5-10 PSI

A7 - 3/8-1 Regulator for 10-20 PSI

A7 - 5/16-1 Regulator for 20-35 PSI

G1 - 1-Stage T87K Mercury Free Thermostat w/Subbase Kit

G2 - 1-Stage T87K Mercury Free Thermostat w/TG511A Guard Kit

G3 - 1-Stage T834N Mercury Free Thermostat/Fan Switch

G5 - 2-Stage TH5220D Mercury Free Thermostat w/Subbase

G6 - Locking Thermostat Cover

G8 - 1-Stage T6169C Line Voltage Stat w/Subbase

G9 - 1-Stage T822K Mercury Free Thermostat

P5 - 24V SPST Relay-Specify Purpose

T1 - Quick Swivel Mounting Bracket

VC-4 - 4" Vent Cap

X2 - 30 Degree Downturn Nozzle

X3 - 60 Degree Downturn Nozzle

X4 - 90 Degree Downturn Nozzle

X7-4 - Combustion Air Inlet Kit (Capacities [CA] 030-075)

X7-5 - Combustion Air Inlet Kit (Capacities [CA] 090-120)

GAS EQUIPMENT START-UP

Customer _____ Job Name & Number _____

PRE-INSPECTION INFORMATION With power and gas off.

Type of Equip: Unit Heater

Serial Number _____ Model Number _____

Name Plate Voltage: _____ Name Plate Amperage: _____

Type of Gas: Natural LP Tank Capacity _____ lbs. Rating: _____ BTU @ _____ °F
_____ kg _____ kw @ _____ °C

- Are all panels, doors, vent caps in place?
- Has the unit suffered any external damage? Damage _____
- Does the gas piping and electric wiring appear to be installed in a professional manner?
- Has the gas and electric been inspected by the local authority having jurisdiction?
- Is the gas supply properly sized for the equipment?
- Were the installation instructions followed when the equipment was installed?
- Have all field installed controls been installed?
- Do you understand all the controls on this equipment? *If not, contact your wholesaler or rep.*
(DO NOT START this equipment unless you fully understand the controls.)

GENERAL

With power and gas off.

- Make certain all packing has been removed.
- Tighten all electrical terminals and connections.
- Check all fans & blowers for free movement.
- Check all controls for proper settings.

FAN

With power on and gas off.

- Check voltage L1 _____ L2 _____ L3 _____
- Check rotation of main fan.
- Check motor amps L1 _____ L2 _____ L3 _____

GAS HEATING

With power and gas on.

- Inlet gas pressure _____ inch WC or _____ kPa
- Burner ignition
- Manifold gas pressure _____ inch WC or _____ kPa
- Cycle and check all other controls not listed.
- Cycle by thermostat or operating control.
- Entering air temperature _____ °F or _____ °C
- Discharge air temperature (high fire) _____ °F or _____ °C
- Combustion readings:
Carbon Monoxide: _____ PPM
Carbon Dioxide: _____ %

Remarks: _____



MESTEK

260 NORTH ELM ST.
WESTFIELD, MA 01085
TEL: (413) 564-5540
FAX: (413) 562-5311
www.mestek.com