

INSTALLATION INSTRUCTIONS & PARTS LIST

HORIZONTAL STEAM AND HOT WATER UNIT HEATERS

ATTENTION: READ THIS MANUAL AND ALL LABELS ATTACHED TO THE UNIT CAREFULLY BEFORE ATTEMPTING TO INSTALL, OPERATE OR SERVICE THESE UNITS! CHECK UNIT DATA PLATE FOR TYPE OF GAS AND ELECTRICAL SPECIFICATIONS AND MAKE CERTAIN THAT THESE AGREE WITH THOSE AT POINT OF INSTALLATION. RECORD THE UNIT MODEL AND SERIAL No.(s) IN THE SPACE PROVIDED. RETAIN FOR FUTURE REFERENCE.

Model No. _____ Serial No. _____

▲ WARNING Improper installation, adjustment, alteration, service or maintenance can cause property damage, injury or death. Read the installation, operating and maintenance instructions thoroughly before installing or servicing this equipment.



INSTALLER'S RESPONSIBILITY

Installer Please Note: This equipment has been tested and inspected. It has been shipped free from defects from our factory. However, during shipment and installation, problems such as loose wires, leaks or loose fasteners may occur. **It is the installer's responsibility to inspect and correct any problems that may be found.**

RECEIVING INSTRUCTIONS

Inspect shipment immediately when received to determine if any damage has occurred to the unit during shipment. After the unit has been uncrated, check for any visible damage to the unit. Turn fan by hand to determine if damage has occurred. If any damage is found, the consignee should sign the bill of lading indicating such damage and immediately file claim for damage with the transportation company.



MESTEK

260 NORTH ELM ST.
WESTFIELD, MA 01085

TABLE OF CONTENTS

| | | | |
|---|-------|--------------------------------------|----|
| GENERAL SAFETY INFORMATION | 3 | ELECTRICAL CONNECTIONS | 17 |
| SPECIFICATIONS | | Operation | 17 |
| Dimensional Data | 4 | Thermostat Wiring and Location | 17 |
| Steam Performance Data | 5 | WIRING INSTALLATION | 18 |
| Steam Calculations & Correction Factors | 6 | OPTIONS | 19 |
| Hot Water Performance Data | 7 | MAINTENANCE | 20 |
| Hot Water Calculations & Correction Factors | 8 | REPLACEMENT PARTS | 21 |
| Technical Data | 9 | TROUBLESHOOTING GUIDE | 22 |
| Motor Data | 10 | WARRANTY | 23 |
| LOCATION | 11 | INSPECTION SHEET | 24 |
| INSTALLATION | | | |
| Unit Mounting | 12 | | |
| Piping | 12-16 | | |

NOTICE: It is the owner's responsibility to provide any scaffolding or other apparatus required to perform emergency service or annual/periodic maintenance to this equipment.

DESCRIPTION

Horizontal hydronic unit heaters are available in both serpentine and header type units. Serpentine units offer outputs from 8,030 to 35,900 BTU's (2.4 to 10.5 kW) and are ideal for hot water (only) installations with limited clearances. Header type horizontal units range from 18,000 to 360,000 (5.3 to 105.5 kW) and can operate with either hot water or steam. Both units are furnished

with totally enclosed motors, with explosion proof motors as optional on header types. The designs are certified by ETL. **Do not alter these units in any way and do not attach any ductwork to the units.** If you have any questions after reading this manual, contact the manufacturer.

Figure 1
Serpentine
Type



Figure 2
Header
Type

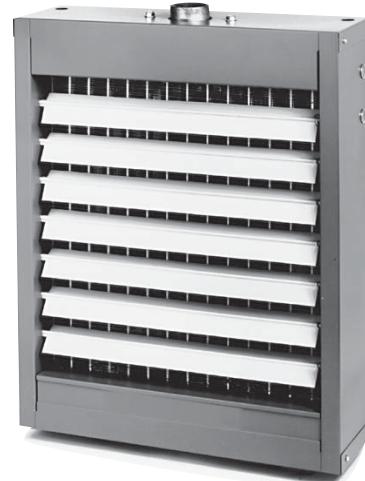

The following terms are used throughout this manual, in addition to ETL requirements, to bring attention to the presence of potential hazards or to important information concerning the product:

▲ DANGER Indicates an imminently hazardous situation which, if not avoided, will result in death, serious injury or substantial property damage.

▲ CAUTION Indicates an imminently hazardous situation which, if not avoided, may result in minor injury or property damage.

▲ WARNING Indicates an imminently hazardous situation which, if not avoided, could result in death, serious injury or substantial property damage.

NOTICE: Used to notify of special instructions on installation, operation or maintenance which are important to equipment but not related to personal injury hazards.

GENERAL SAFETY INFORMATION

▲ WARNING Failure to comply with the general safety information may result in extensive property damage, severe personal injury or death.

▲ WARNING Do not alter the unit heater in any way or damage to the unit and/or severe personal injury or death may occur!

▲ WARNING Disconnect all power supplies before installing or servicing the heater. If the power disconnect is out of sight, lock it in the open position and tag it to prevent unexpected application of power. Failure to do so could result in fatal electric shock, or severe personal injury.

▲ CAUTION Insure that all power sources conform to the requirements of the unit heater or damage to the unit will result!

Follow installation instructions CAREFULLY to avoid creating unsafe conditions. All external wiring must conform to applicable current local codes, and to the latest edition of the National Electric Code ANSI/NFPA No. 70. In Canada, all external wiring must conform to the Canadian Electric Code, Part 1 CSA Standard C22.1 All wiring should be done and checked by a qualified electrician using copper wire only. All steam and hot water connections should be made and leak-tested by a suitably qualified individual, per instructions in this manual. Also follow procedures listed on the "Unit Equipment Start-Up Sheet" located in this manual.

Make certain that the power source conforms to the electrical requirements of the heater.

▲ WARNING Do not depend upon a thermostat or other switch as sole means of disconnecting power when installing or servicing heater. Always disconnect power at main circuit breaker as described above. Failure to do so could result in fatal electric shock.

Special attention must be given to any grounding information pertaining to this heater. To prevent the risk of electrocution, the heater must be securely and adequately grounded. This should be accomplished by connecting a grounded conductor between the service panel and the heater. To ensure a proper ground, the grounding means must be tested by a qualified electrician.

Do not insert fingers or foreign objects into the heater or its air moving device. Do not block or tamper with the heater in any manner while in operation or just after it has been turned off, as some parts may be hot enough to cause injury.

To meet ETL and OSHA requirements, units mounted below 8 feet (2.4m) from the floor must be equipped with an OSHA fan guard.

It is good practice to have a shutoff switch on the electrical power lines controlling the heater. Whenever a unit is serviced, shut power off to the unit.

Since these units are installed in most instances higher than 8 feet (2.4m), proper type of ladders or scaffolding should be used, as set up by OSHA requirements (see Notice on page 2).

In industrial plants, professional maintenance crews should service this equipment.

All Horizontal Unit Heaters are shipped fully assembled and may be used for steam or hot water applications. Coils are factory tested at 250 psig (1723.5 kg).

Each unit is packaged individually and marked for proper identification. Use normal care in handling and during installation to prevent damage to the coils fins, fan and casing.

| | |
|---|---|
| Unless otherwise specified, the following conversions may be used for calculating SI unit measurements: | |
| 1 foot = 0.305 m | 1 inch water column = 0.249 kPa |
| 1 inch = 25.4 mm | meter/second = FPM ÷ 196.8 |
| 1 psig = 6.894 kPa | liter/second = CFM x 0.472 |
| 1 pound = 0.453 kg | 1000 Btu per hour = 0.293 kW |
| 1 gallon = 3.785 L | 1000 Btu/Cu. Ft. = 37.5 MJ/m ³ |
| | 1 cubic foot = 0.028 m ³ |

DIMENSIONAL DATA

**Figure 3 – Serpentine Type
Models 108A, 118A, 125A, 136A**

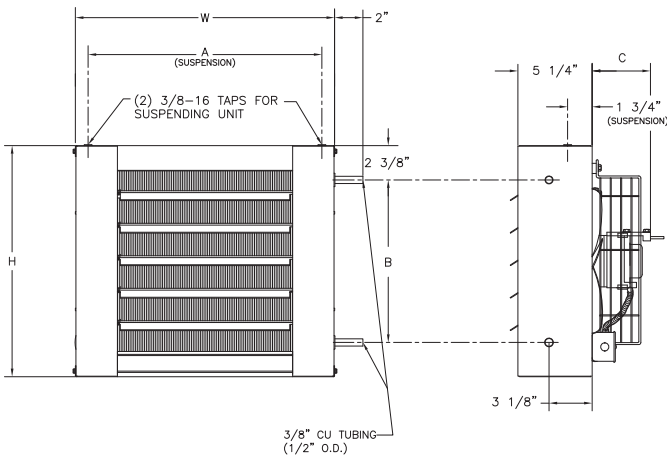

NOTE: Motors are totally enclosed, thermally protected, sleeve bearing, with 2" (h) x 4" (w) conduit connection boxes. 3/8-16 nutserts are attached to enclosure for balanced hanging.

**Figure 4 – Header Type
Models 18 thru 360**

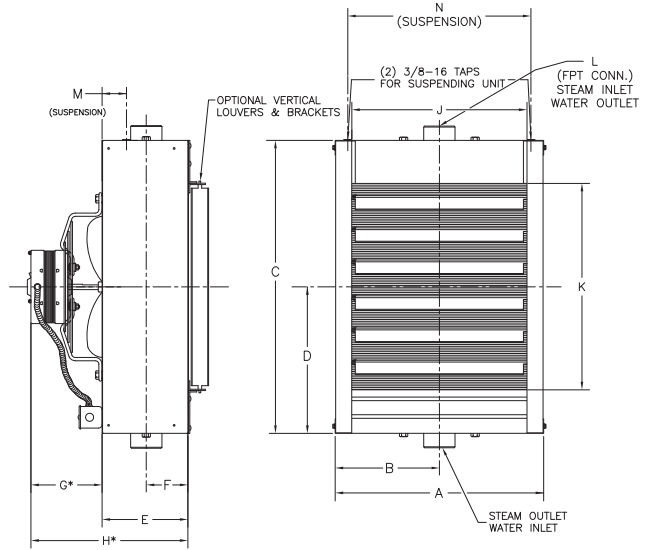

Table 1 – Figure 3 Serpentine Models

| MODEL | H inches (mm) | W inches (mm) | A inches (mm) | B inches (mm) | C inches (mm) | NO. OF LOUVERS | NOM. FAN DIAM. inches (mm) | APPROX. SHIP WT. lbs. (kg) |
|-------|--------------------------------------|--------------------------------------|--|--------------------------------------|--------------------------------------|----------------|-------------------------------|-------------------------------|
| 108A | 16 (406) | 18 (457) | 16 ⁷ / ₃₂ (412) | 11 ¹ / ₄ (286) | 4 ¹ / ₄ (108) | 5 | 9 (229) | 22 (10.0) |
| 118A | 16 (406) | 18 (457) | 16 ⁷ / ₃₂ (412) | 11 ¹ / ₄ (286) | 4 ¹ / ₄ (108) | 5 | 10 (254) | 24 (10.9) |
| 125A | 16 (406) | 18 (457) | 16 ⁷ / ₃₂ (412) | 11 ¹ / ₄ (286) | 4 ¹ / ₄ (108) | 5 | 10 (254) | 25 (11.3) |
| 136A | 18 ¹ / ₂ (470) | 20 ¹ / ₂ (521) | 18 ²² / ₃₂ (475) | 13 ³ / ₄ (349) | 5 ¹ / ₁₆ (144) | 6 | 12 (305) | 31 (14.0) |

Table 2 – Figure 4 Header Models

| MODEL | A inches (mm) | B inches (mm) | C inches (mm) | D inches (mm) | E inches (mm) | F inches (mm) | G* inches (mm) | H* inches (mm) | J inches (mm) | K inches (mm) | L inches (mm) | M inches (mm) | N inches (mm) | NO. OF LOUVERS | NOM. FAN DIAM. inches (mm) | APPROX. SHIP WT. lbs. (kg) |
|-------|--------------------------------------|--|--------------------------------------|--------------------------------------|--------------------------------------|--------------------------------------|--------------------------------------|--|--------------------------------------|--------------------------------------|------------------------------------|------------------------------------|--------------------------------------|----------------|-------------------------------|-------------------------------|
| 18 | 14 ⁵ / ₈ (371) | 7 ⁵ / ₁₆ (186) | 15 (381) | 7 ¹ / ₂ (191) | 6 ¹ / ₈ (156) | 2 ¹⁵ / ₁₆ (75) | 3 ¹ / ₄ (83) | 9 ³ / ₈ (238) | 12 ¹ / ₄ (311) | 9 ¹ / ₂ (241) | 1 ¹ / ₄ (32) | 2 ¹ / ₄ (57) | 12 ⁷ / ₈ (327) | 4 | 9 (229) | 26 (11.8) |
| 24 | 14 ⁵ / ₈ (371) | 7 ⁵ / ₁₆ (186) | 18 (457) | 9 (229) | 6 ¹ / ₈ (156) | 2 ¹⁵ / ₁₆ (75) | 3 ¹ / ₄ (83) | 9 ³ / ₈ (238) | 12 ¹ / ₄ (311) | 12 ¹ / ₂ (318) | 1 ¹ / ₄ (32) | 2 ¹ / ₄ (57) | 12 ⁷ / ₈ (327) | 5 | 10 (254) | 30 (13.6) |
| 36 | 17 ¹ / ₈ (435) | 8 ⁹ / ₁₆ (217) | 20 ¹ / ₂ (521) | 10 ¹ / ₄ (260) | 5 ⁷ / ₈ (149) | 2 ¹⁵ / ₁₆ (75) | 5 ¹ / ₁₆ (144) | 11 ⁷ / ₁₆ (291) | 14 ³ / ₄ (375) | 15 (381) | 1 ¹ / ₄ (32) | 1 ³ / ₄ (44) | 15 ⁵ / ₈ (391) | 6 | 12 (305) | 41 (18.6) |
| 48 | 17 ¹ / ₈ (435) | 8 ⁹ / ₁₆ (217) | 20 ¹ / ₂ (521) | 10 ¹ / ₄ (260) | 5 ⁷ / ₈ (149) | 2 ¹⁵ / ₁₆ (75) | 5 ¹ / ₁₆ (129) | 10 ¹⁵ / ₁₆ (278) | 14 ³ / ₄ (375) | 15 (381) | 1 ¹ / ₄ (32) | 1 ³ / ₄ (44) | 15 ³ / ₈ (391) | 6 | 12 (305) | 41 (18.6) |
| 60 | 18 ³ / ₈ (467) | 9 ⁹ / ₁₆ (233) | 21 ³ / ₄ (552) | 10 ⁷ / ₈ (276) | 6 (152) | 2 ¹⁵ / ₁₆ (75) | 5 ¹ / ₁₆ (129) | 11 ¹ / ₁₆ (281) | 16 (406) | 16 ¹ / ₄ (413) | 1 ¹ / ₄ (32) | 1 ³ / ₄ (44) | 16 ⁵ / ₈ (422) | 7 | 14 (356) | 44 (19.9) |
| 72 | 20 ⁷ / ₈ (530) | 10 ⁷ / ₁₆ (265) | 24 ¹ / ₄ (616) | 12 ¹ / ₈ (308) | 6 ¹ / ₈ (156) | 2 ¹⁵ / ₁₆ (75) | 5 ¹ / ₁₆ (144) | 11 ¹³ / ₁₆ (300) | 18 ¹ / ₂ (470) | 18 ³ / ₄ (476) | 1 ¹ / ₄ (32) | 1 ³ / ₄ (44) | 19 ¹ / ₈ (486) | 8 | 14 (356) | 47 (21.3) |
| 84 | 19 ⁵ / ₈ (498) | 9 ⁹ / ₁₆ (249) | 24 (610) | 12 (305) | 6 ¹ / ₈ (160) | 3 ⁹ / ₁₆ (81) | 7 ¹ / ₂ (191) | 13 ¹³ / ₁₆ (351) | 17 ¹ / ₄ (438) | 17 ¹ / ₂ (445) | 1 ¹ / ₂ (38) | 1 ³ / ₄ (44) | 17 ⁷ / ₈ (454) | 8 | 16 (406) | 49 (22.2) |
| 108 | 20 ⁷ / ₈ (530) | 10 ⁷ / ₁₆ (265) | 25 ¹ / ₄ (641) | 12 ⁵ / ₈ (321) | 6 ⁵ / ₁₆ (160) | 3 ⁹ / ₁₆ (81) | 6 ¹ / ₁₆ (170) | 13 (330) | 18 ¹ / ₂ (470) | 18 ³ / ₄ (476) | 1 ¹ / ₂ (38) | 1 ³ / ₄ (44) | 19 ¹ / ₈ (486) | 8 | 18 (457) | 59 (26.7) |
| 120 | 23 ³ / ₈ (594) | 11 ¹ / ₁₆ (297) | 27 ³ / ₄ (705) | 13 ⁷ / ₈ (352) | 6 ⁵ / ₁₆ (160) | 3 ⁹ / ₁₆ (81) | 7 ⁵ / ₈ (194) | 14 (356) | 21 (533) | 21 ¹ / ₄ (540) | 1 ¹ / ₂ (38) | 1 ³ / ₄ (44) | 21 ⁵ / ₈ (549) | 9 | 18 (457) | 74 (33.5) |
| 144 | 23 ³ / ₈ (594) | 11 ¹ / ₁₆ (297) | 27 ³ / ₄ (705) | 13 ⁷ / ₈ (352) | 6 ⁵ / ₁₆ (160) | 3 ⁹ / ₁₆ (81) | 7 ⁷ / ₁₆ (194) | 13 ³ / ₄ (349) | 21 (533) | 21 ¹ / ₄ (540) | 1 ¹ / ₂ (38) | 1 ³ / ₄ (44) | 21 ⁵ / ₈ (549) | 9 | 18 (457) | 74 (33.5) |
| 156 | 24 ³ / ₈ (625) | 12 ⁵ / ₁₆ (313) | 29 (737) | 14 ¹ / ₂ (368) | 6 ³ / ₈ (162) | 3 ⁹ / ₁₆ (81) | 7 ⁷ / ₁₆ (194) | 13 ³ / ₄ (349) | 22 ¹ / ₄ (565) | 22 ¹ / ₂ (572) | 1 ¹ / ₂ (38) | 1 ³ / ₄ (44) | 22 ⁷ / ₈ (581) | 9 | 18 (457) | 90 (40.8) |
| 204 | 27 ⁷ / ₈ (708) | 13 ¹⁵ / ₁₆ (354) | 30 ³ / ₄ (768) | 15 ¹ / ₈ (384) | 8 ¹ / ₈ (206) | 3 ⁹ / ₁₆ (81) | 5 ⁷ / ₈ (149) | 14 (356) | 25 ¹ / ₂ (648) | 23 ³ / ₄ (603) | 2 (51) | 1 ³ / ₄ (44) | 26 ¹ / ₈ (664) | 10 | 20 (508) | 143 (65) |
| 240 | 27 ⁷ / ₈ (708) | 13 ¹⁵ / ₁₆ (354) | 30 ³ / ₄ (768) | 15 ¹ / ₈ (384) | 8 ¹ / ₈ (206) | 3 ⁹ / ₁₆ (81) | 9 ⁵ / ₈ (244) | 17 ³ / ₄ (451) | 25 ¹ / ₂ (648) | 23 ³ / ₄ (603) | 2 (51) | 1 ³ / ₄ (44) | 26 ¹ / ₈ (664) | 10 | 20 (508) | 154 (70) |
| 280 | 33 ³ / ₈ (848) | 16 ¹ / ₁₆ (424) | 37 ³ / ₄ (959) | 18 ⁷ / ₈ (479) | 9 (229) | 3 ⁹ / ₁₆ (81) | 9 ⁵ / ₈ (244) | 18 ⁵ / ₈ (473) | 31 (787) | 31 ¹ / ₄ (794) | 2 (51) | 1 ³ / ₄ (44) | 31 ⁵ / ₈ (803) | 13 | 24 (610) | 203 (92) |
| 300 | | | | | | | | | | | | | | | | |
| 360 | | | | | | | | | | | | | | | | |

* Applies to standard motor with standard fan guard. When optional motors or OSHA fan guards are requested, dimensions will vary according to the substitutions made.

- NOTES: 1. OSHA guard standard on all serpentine models and header models 18 thru 48 supplied with 1 phase motors (dimensions shown in tables).
 2. Standard motor and standard guard shown.
 3. All 3 phase and explosion proof motors are shelf mounted.

STEAM PERFORMANCE DATA

Table 3 - Header Type Models only

| Unit Size | Output BTU/HR* (kW) | Cond. lbs./hr. (kg/hr) | E.D.R. Sq. Ft. (sq. m) | Final Air Deg. °F (Deg. °C) | Motor HP (kW) | RPM | Nominal CFM (m³/s) | Outlet FPM (m/s) | Nom. Amps @ 115VAC† | Nom. Fan Diam. Inches (mm) |
|-----------|---------------------|------------------------|------------------------|-----------------------------|----------------|------|--------------------|------------------|---------------------|----------------------------|
| 18 | 18,000 (5.3) | 18.0 (8.2) | 75 (7.0) | 102 (39) | 16 Watts | 1550 | 395 (.186) | 395 (2.007) | 0.80 | 9 (228.6) |
| | 16,200 (4.7) | 16.2 (7.3) | 68 (6.3) | 105 (41) | | 1350 | 330 (.156) | 330 (1.676) | | 9 (228.6) |
| 24 | 24,000 (7.0) | 24.5 (11.1) | 100 (9.3) | 109 (43) | 16 Watts | 1550 | 450 (.212) | 450 (2.286) | 0.80 | 10 (254.0) |
| | 21,600 (6.3) | 22.0 (10.0) | 90 (8.4) | 112 (44) | | 1350 | 380 (.179) | 380 (1.930) | | 10 (254.0) |
| 36 | 36,000 (10.5) | 37.0 (16.8) | 150 (13.9) | 119 (48) | 25 Watts | 1550 | 550 (.260) | 550 (2.794) | 1.2 | 10 (254.0) |
| | 32,400 (9.5) | 33.0 (14.9) | 135 (12.5) | 120 (49) | | 1350 | 480 (.227) | 480 (2.438) | | 10 (254.0) |
| 48 | 48,000 (14.1) | 49.0 (22.2) | 200 (18.6) | 119 (48) | 1/20 (.037) | 1000 | 750 (.354) | 550 (2.794) | 1.4 | 12 (304.8) |
| | 43,200 (12.7) | 44.0 (19.9) | 180 (16.7) | 123 (51) | | 900 | 630 (.297) | 460 (2.337) | | 12 (304.8) |
| 60 | 60,000 (17.6) | 61.0 (27.6) | 250 (23.2) | 121 (49) | 1/20 (.037) | 1000 | 900 (.425) | 650 (3.302) | 1.4 | 12 (304.8) |
| | 54,000 (15.8) | 55.0 (24.9) | 225 (20.9) | 131 (55) | | 900 | 700 (.330) | 510 (2.591) | | 12 (304.8) |
| 72 | 72,000 (21.1) | 73.0 (33.1) | 300 (27.9) | 120 (49) | 1/20 (.037) | 1000 | 1100 (.519) | 800 (4.064) | 1.4 | 14 (355.6) |
| | 64,800 (19.0) | 66.0 (29.9) | 270 (25.1) | 123 (51) | | 900 | 950 (.448) | 700 (3.556) | | 14 (355.6) |
| 84 | 84,000 (24.6) | 85.0 (38.5) | 350 (32.5) | 115 (46) | 1/12 (.062) | 1000 | 1400 (.661) | 900 (4.572) | 2.2 | 14 (355.6) |
| | 75,600 (22.2) | 76.0 (34.4) | 315 (29.3) | 123 (51) | | 900 | 1100 (.519) | 750 (3.810) | | 14 (355.6) |
| 96 | 96,000 (28.1) | 97.0 (43.9) | 400 (37.2) | 123 (51) | 1/12 (.062) | 1000 | 1400 (.661) | 930 (4.724) | 2.2 | 16 (406.4) |
| | 86,400 (25.3) | 88.0 (39.9) | 360 (33.4) | 132 (56) | | 900 | 1100 (.519) | 800 (4.064) | | 16 (406.4) |
| 108 | 108,000 (31.6) | 110.0 (49.8) | 450 (41.8) | 115 (46) | 1/12 (.062) | 1000 | 1800 (.850) | 1000 (5.080) | 2.2 | 16 (406.4) |
| | 97,200 (28.5) | 98.0 (44.4) | 405 (37.6) | 120 (49) | | 900 | 1500 (.708) | 900 (4.572) | | 16 (406.4) |
| 120 | 120,000 (35.2) | 122.0 (55.3) | 500 (46.5) | 118 (48) | 1/3 (.249) | 1140 | 1900 (.897) | 900 (4.572) | 4.5 | 18 (457.2) |
| 132 | 132,000 (38.7) | 134.0 (60.7) | 550 (51.1) | 121 (49) | 1/3 (.249) | 1140 | 2000 (.944) | 950 (4.826) | 4.5 | 18 (457.2) |
| 144 | 144,000 (42.2) | 146.0 (66.1) | 600 (55.7) | 120 (49) | 1/3 (.249) | 1140 | 2200 (1.038) | 1000 (5.080) | 4.5 | 18 (457.2) |
| 156 | 156,000 (45.7) | 160.0 (72.5) | 650 (60.4) | 115 (46) | 1/3 (.249) | 1140 | 2600 (1.227) | 1150 (5.842) | 4.5 | 18 (457.2) |
| 180 | 180,000 (52.7) | 190.0 (86.1) | 770 (71.5) | 135 (57) | 1/3 (.249) | 1140 | 2200 (1.038) | 800 (4.064) | 4.5 | 18 (457.2) |
| 204 | 204,000 (59.8) | 208.0 (94.2) | 850 (79.0) | 124 (51) | 1/3 (.249) | 1140 | 2900 (1.369) | 1000 (5.080) | 4.5 | 18 (457.2) |
| 240 | 240,000 (70.3) | 244.0 (110.5) | 1000 (92.9) | 123 (51) | 1/3 (.249) | 1140 | 3500 (1.652) | 900 (4.572) | 4.5 | 20 (508.0) |
| 280 | 280,000 (82.0) | 280.0 (126.8) | 1100 (102.2) | 121 (49) | 1/2 (.373) | 1100 | 4200 (1.982) | 980 (4.978) | 5.4 | 20 (508.0) |
| 300 | 300,000 (87.9) | 310.0 (140.4) | 1250 (116.1) | 117 (47) | 1/2 (.373) | 1100 | 5000 (2.360) | 700 (3.556) | 5.4 | 24 (609.6) |
| 360 | 360,000 (105.5) | 366.0 (165.8) | 1500 (139.4) | 120 (49) | 1/2 (.373) | 1100 | 5500 (2.596) | 1000 (5.080) | 5.4 | 24 (609.6) |

Performance based on 2# steam pressure (13.8 kpa) at heater with air entering @ 60°F (16°C).

For Sound Ratings See Pages 7 & 9.

Use conversion Table on page 3 for all metric conversions.

* For the lower output, an optional Speed Controller must be ordered.

† Stated AMP is full load for the standard motors. AMP draw varies by motor manufacturer ± 0.2 AMPS. Please see your unit's motor data plate for exact (FLA) Full Load Amp rating. Additional motor data is shown on page 10.

STEAM CALCULATIONS AND CORRECTION FACTORS

EXAMPLE: –
 UNIT SIZE: _____ 24
 Steam Pressure ___ 10 PSI
 Entering Air Temp. ___ 40°F

| | | |
|---|--|---|
| I. CAPACITY | | |
| A. For 2 lbs. steam, 60° entering air | Read output directly from Table 3, 24,000 BTU/HR. (Ref., Std. 24). | |
| B. For higher steam pressures and/or E.A.T.'s above or below 60°F | Multiply output from Table 3 by appropriate correction factor from Table 4 (below). | 24,000 x 1.29 = 30,960 BTU/HR. |
| II. FINAL AIRTEMPERATURE | | |
| A. For 2 lbs. steam, 60° entering air | Read temperature directly from Table 3, 109°F. (Ref., Std. 24). | |
| B. For capacities calculated in I.B. (above) | $\frac{\text{Output from I.B.}}{1.085 \times \text{CFM from Table 3}} + \text{E.A.T.} = \text{Final Air Temp.}$ | $\frac{30,960}{1.085 \times 450} + 40 = 103.4^\circ\text{F.}$ |
| III. FINAL AIRVOLUME | | |
| A. For 2 lbs. steam, 60° entering air | $\frac{460 + \text{Final Air Temp from Table 3}}{530} \times \begin{matrix} \text{Nom. CFM} \\ \text{from} \\ \text{Table 3} \end{matrix} = \begin{matrix} \text{Final} \\ \text{Air} \\ \text{Volume} \end{matrix}$ | $\frac{460 + 109}{530} \times 450 = 483 \text{ CFM}$ |
| B. For final air temperatures calculated in II.B. (above) | $\frac{460 + \text{Final Air Temp from II.B.}}{530} \times \begin{matrix} \text{Nom. CFM} \\ \text{from} \\ \text{Table 3} \end{matrix} = \begin{matrix} \text{Final} \\ \text{Air} \\ \text{Volume} \end{matrix}$ | $\frac{460 + 103.4}{530} \times 450 = 478 \text{ CFM}$ |
| IV. CONDENSATE PER HOUR | | |
| A. For 2 lbs. steam, 60° entering air | Read lbs. per hour from Table 3, 24.5 LBS./HR. (Ref., Std. 24). | |
| B. For capacities calculated in I.B. (above) | $\frac{\text{Output from I.B.}}{\text{Latent Heat From Table 5}} = \text{lbs. per hour of condensate}$ | $\frac{30,960}{953} = 32.5 \text{ LBS./HR.}$ |

TABLE 4 — STEAM CORRECTION FACTORS BASED ON 2 PSI (13.8 kPa) STEAM AND 60 Deg. F (16 Deg. C) E.A.T.

| ENTERING AIR TEMPERATURE Deg. F (Deg. C) | STEAM PRESSURE (SATURATED) — LBS. PER SQ. IN. (kPa) | | | | | | | | | | | | |
|---|---|-------------|-------------|--------------|---------------|---------------|---------------|---------------|---------------|---------------|----------------|----------------|------------------|
| | 0 (0) | 2 (13.8) | 5 (34.5) | 10 (68.9) | 15 (103.4) | 20 (137.9) | 30 (206.8) | 40 (275.8) | 50 (344.7) | 75 (517.1) | 100 (689.4) | 125 (861.8) | 150 (1,034.1) |
| 30 (-1) | 1.19 | 1.24 | 1.29 | 1.38 | 1.44 | 1.50 | 1.60 | 1.68 | 1.70 | 1.90 | 2.02 | 2.11 | 2.20 |
| 40 (4) | 1.11 | 1.16 | 1.21 | 1.29 | 1.34 | 1.42 | 1.51 | 1.60 | 1.66 | 1.81 | 1.93 | 2.02 | 2.11 |
| 50 (10) | 1.03 | 1.08 | 1.13 | 1.21 | 1.28 | 1.33 | 1.43 | 1.51 | 1.58 | 1.72 | 1.84 | 1.93 | 2.02 |
| 60 (16) | 0.96 | 1.00 | 1.05 | 1.13 | 1.19 | 1.25 | 1.35 | 1.43 | 1.50 | 1.64 | 1.75 | 1.84 | 1.93 |
| 70 (21) | 0.88 | 0.93 | 0.97 | 1.06 | 1.12 | 1.17 | 1.27 | 1.35 | 1.42 | 1.55 | 1.66 | 1.76 | 1.84 |
| 80 (27) | 0.81 | 0.85 | 0.90 | 0.98 | 1.04 | 1.10 | 1.19 | 1.27 | 1.34 | 1.47 | 1.58 | 1.68 | 1.76 |
| 90 (32) | 0.74 | 0.78 | 0.83 | 0.91 | 0.97 | 1.02 | 1.12 | 1.19 | 1.26 | 1.39 | 1.50 | 1.59 | 1.67 |
| 100 (38) | 0.67 | 0.71 | 0.76 | 0.84 | 0.89 | 0.95 | 1.04 | 1.12 | 1.19 | 1.32 | 1.42 | 1.51 | 1.59 |

TABLE 5 — PROPERTIES OF SATURATED STEAM

| | STEAM PRESSURE IN PSIG (kPa) | | | | | | | | | | | | |
|---|------------------------------|------------------|------------------|------------------|------------------|------------------|------------------|------------------|------------------|------------------|------------------|------------------|------------------|
| | 0 (0) | 2 (13.8) | 5 (34.5) | 10 (68.9) | 15 (103.4) | 20 (137.9) | 30 (206.8) | 40 (275.8) | 50 (344.7) | 75 (517.1) | 100 (689.4) | 125 (891.8) | 150 (1,034.1) |
| Steam Pressure psi (kPa) | 212 (100) | 218.5 (103.6) | 227.1 (108.4) | 239.4 (115.2) | 249.8 (121.0) | 258.8 (126.0) | 274.0 (134.4) | 286.7 (141.5) | 297.7 (147.6) | 319.9 (159.9) | 337.9 (169.9) | 352.9 (178.3) | 365.9 (185.5) |
| Latent Heat of Steam Btu/lbm (KJ/Kg) | 970 (2256) | 966 (2247) | 961 (2235) | 953 (2217) | 946 (2200) | 940 (2186) | 929 (2161) | 920 (2140) | 912 (2121) | 891 (2072) | 881 (2049) | 868 (2019) | 857 (1993) |

HOT WATER PERFORMANCE DATA

Table 6 - Serpentine and Header Type Models

| Unit Size | Output BTU/HR* (kW) | Flow Rate GPM (L/s) | Final Air Deg. °F (Deg. °C) | Prssr. Drop FT./H ₂ O (m/water) | Motor HP (kW) | RPM | Nominal CFM (m ³ /s) | Outlet FPM (m/s) | Nom. Amps @ 115VAC† | Sound Rating |
|-----------|---------------------|---------------------|-----------------------------|--|----------------|------|---------------------------------|------------------|---------------------|--------------|
| 108A | 8,030 (2.4) | 0.8 (.050) | 91 (33) | 0.80 (.244) | 16 Watts | 1550 | 245 (.116) | 250 (1.270) | 0.80 | II |
| | 6,800 (2.0) | | 90 (32) | | | 1350 | 210 (.099) | 215 (1.092) | | I |
| 118A | 18,400 (5.4) | 1.9 (.120) | 94 (34) | 2.20 (.671) | 16 Watts | 1550 | 500 (.236) | 500 (2.540) | 0.80 | II |
| | 15,650 (4.6) | | 96 (36) | | | 1350 | 420 (.198) | 420 (2.134) | | I |
| 125A | 24,800 (7.3) | 2.5 (.158) | 102 (39) | 2.20 (.671) | 25 Watts | 1550 | 580 (.274) | 590 (2.997) | 1.2 | II |
| | 21,230 (6.2) | | 106 (41) | | | 1350 | 460 (.217) | 450 (2.286) | | I |
| 136A | 35,900 (10.5) | 3.6 (.227) | 99 (37) | 3.00 (.914) | 1/20 (.037) | 1000 | 850 (.401) | 550 (2.794) | 1.4 | II |
| | 32,300 (9.5) | | 100 (38) | | | 900 | 750 (.354) | 480 (2.438) | | I |
| 18 | 13,050 (3.8) | 1.3 (.082) | 95 (35) | 0.005 (.002) | 16 Watts | 1550 | 395 (.186) | 395 (2.007) | 0.80 | II |
| | 11,725 (3.4) | | 99 (37) | | | 1350 | 350 (.165) | 350 (1.778) | | I |
| 24 | 17,400 (5.1) | 1.8 (.114) | 96 (36) | 0.014 (.004) | 16 Watts | 1550 | 450 (.212) | 450 (2.286) | 0.80 | II |
| | 15,600 (4.6) | | 98 (37) | | | 1350 | 380 (.179) | 380 (1.930) | | I |
| 36 | 26,100 (7.6) | 2.7 (.170) | 103 (39) | 0.09 (.027) | 25 Watts | 1550 | 550 (.260) | 550 (2.794) | 1.2 | II |
| | 23,500 (6.9) | | 103 (39) | | | 1350 | 480 (.227) | 480 (2.438) | | I |
| 48 | 34,800 (10.2) | 3.5 (.221) | 103 (39) | 0.12 (.037) | 1/20 (.037) | 1000 | 750 (.354) | 550 (2.794) | 1.4 | II |
| | 31,300 (9.2) | | 111 (44) | | | 900 | 630 (.297) | 460 (2.337) | | I |
| 60 | 43,600 (12.8) | 4.4 (.278) | 105 (41) | 0.17 (.052) | 1/20 (.037) | 1000 | 900 (.425) | 650 (3.302) | 1.4 | II |
| | 39,200 (11.5) | | 112 (44) | | | 900 | 700 (.330) | 510 (2.591) | | I |
| 72 | 52,300 (15.3) | 5.3 (.334) | 104 (40) | 0.23 (.070) | 1/20 (.037) | 1000 | 1100 (.519) | 800 (4.064) | 1.4 | II |
| | 47,000 (13.8) | | 106 (41) | | | 900 | 950 (.448) | 700 (3.556) | | I |
| 84 | 61,000 (17.9) | 6.1 (.385) | 100 (38) | 0.24 (.073) | 1/12 (.062) | 1000 | 1400 (.661) | 900 (4.572) | 2.2 | III |
| | 54,900 (16.1) | | 106 (41) | | | 900 | 1100 (.519) | 750 (3.810) | | II |
| 96 | 69,700 (20.4) | 7.0 (.442) | 106 (41) | 0.29 (.088) | 1/12 (.062) | 1000 | 1400 (.661) | 930 (4.724) | 2.2 | III |
| | 62,700 (18.4) | | 113 (45) | | | 900 | 1100 (.519) | 800 (4.064) | | II |
| 108 | 78,400 (23.0) | 7.9 (.498) | 100 (38) | 0.36 (.110) | 1/12 (.062) | 1000 | 1800 (.850) | 1000 (5.080) | 2.2 | III |
| | 70,500 (20.7) | | 103 (39) | | | 900 | 1500 (.708) | 900 (4.572) | | II |
| 120 | 87,100 (25.5) | 8.8 (.555) | 102 (39) | 0.39 (.119) | 1/3 (.249) | 1140 | 1900 (.897) | 900 (4.572) | 4.5 | III |
| | 95,800 (28.1) | | 104 (40) | | | 1140 | 2000 (.944) | 950 (4.826) | | IV |
| 144 | 104,000 (30.5) | 10.4 (.656) | 104 (40) | 0.43 (.131) | 1/3 (.249) | 1140 | 2200 (1.038) | 1000 (5.080) | 4.5 | IV |
| | 113,000 (33.1) | | 100 (38) | | | 1140 | 2600 (1.227) | 1150 (5.842) | | IV |
| 180 | 118,000 (34.6) | 11.8 (.744) | 110 (43) | 0.6 (.183) | 1/3 (.249) | 1140 | 2200 (1.038) | 800 (4.064) | 4.5 | III |
| | 148,000 (43.4) | | 107 (42) | | | 1140 | 2900 (1.369) | 1000 (5.080) | | IV |
| 240 | 174,000 (51.0) | 17.4 (1.098) | 106 (41) | 1.06 (.323) | 1/3 (.249) | 1140 | 3500 (1.652) | 900 (4.572) | 4.5 | IV |
| | 209,100 (61.3) | | 106 (41) | | | 1100 | 4200 (1.982) | 980 (4.978) | | IV |
| 280 | 230,000 (67.4) | 23.0 (1.451) | 102 (39) | 2.1 (.640) | 1/2 (.373) | 1100 | 5000 (2.360) | 700 (3.556) | 5.4 | IV |
| | 261,300 (76.6) | | 103 (39) | | | 1100 | 5500 (2.596) | 1000 (5.080) | | IV |

Performance based on 200°F (93°C) EWT, 60°F (16°C) E.A.T., 20°F (11°C)TD.

For Fan Diameter See Page 4.

Use conversion Table on page 3 for all metric conversions.

* For the lower output, an optional Speed Controller must be ordered.

† Stated AMP is full load for standard motors. AMP draw varies by motor manufacturer ± 0.2 AMPS. Please see your unit's motor data plate for exact (FLA) Full Load Amp rating. Additional motor data is shown on page 10.

HOT WATER CALCULATIONS AND CORRECTION FACTORS

EXAMPLE: –

UNIT SIZE: _____ 24
 Entering Water Temp. _____ 160°F
 Entering Air Temp. _____ 40°F
 Water Temperature Drop _____ 10°F

| | | |
|---|--|---|
| I. CAPACITY @ 20° TD: A. For 200° EWT, 60° EAT | Read output directly from Table 6, 17,400 BTU/HR (Ref., Std. 24). | |
| B. For EWT and/or EAT above or below Standard | Multiply output from Table 6 by factor from Table 7 (below). | 17,400 x .878 = 15,277 BTU/HR. |
| II. CAPACITY AT OTHER TD's A. For TD's from 5 to 60°F | Multiply output obtained in IA. or IB. (above) by appropriate factor from Table 8 (below) | IA - 17,400 x 1.15 = 20,010 BTU/HR. – OR – IB - 15,277 x 1.15 = 17,569 BTU/HR. |
| III. GPM AT OTHER TD's A. For TD's from 5 to 60°F | Multiply GPM of unit for 20° TD, from Table 6 by appropriate factor from Table 8 (below). | 1.8 x 2.30 = 4.14 GPM (Applies only to units with Std. 200° EWT, 60° EAT.) For all others calculate using formula – $GPM = \frac{BTU}{500 \times TD}$ |
| IV. CAPACITY AT OTHER RATES OF WATER FLOW | Multiply output from Table 6 by factor from Table 10 (below). | |
| V. PRESSURE LOSS AT OTHER TD's A. For TD's from 5 to 60°F | Multiply P.D. of unit for 20° TD, from Table 6 by appropriate factor from Table 8 (below). | .014 x 5.00 = .07 Ft. H ₂ O |

TABLE 7 — HOT WATER CONVERSION FACTORS BASED ON 200° (93°C) ENTERING WATER, 60° (16°C) ENTERING AIR AND 20° (11°C) TEMPERATURE DROP

| ENTERING AIR TEMPERATURE °F (°C) | ENTERING WATER TEMPERATURE — °F (°C) | | | | | | | | | | |
|-------------------------------------|--------------------------------------|--------------|--------------|--------------|--------------|--------------|---------------|---------------|---------------|---------------|---------------|
| | 100° (38) | 120° (49) | 140° (60) | 160° (71) | 180° (82) | 200° (93) | 220° (104) | 240° (116) | 260° (127) | 280° (138) | 300° (149) |
| 30 (-1) | 0.518 | 0.666 | 0.814 | 0.963 | 1.120 | 1.268 | 1.408 | 1.555 | 1.702 | 1.850 | 1.997 |
| 40 (4) | 0.439 | 0.585 | 0.731 | 0.878 | 1.025 | 1.172 | 1.317 | 1.464 | 1.609 | 1.755 | 1.908 |
| 50 (10) | 0.361 | 0.506 | 0.651 | 0.796 | 0.941 | 1.085 | 1.231 | 1.375 | 1.518 | 1.663 | 1.824 |
| 60 (16) | 0.286 | 0.429 | 0.571 | 0.715 | 0.857 | 1.000 | 1.143 | 1.286 | 1.429 | 1.571 | 1.717 |
| 70 (21) | 0.212 | 0.353 | 0.494 | 0.636 | 0.777 | 0.918 | 1.060 | 1.201 | 1.342 | 1.483 | 1.630 |
| 80 (27) | 0.140 | 0.279 | 0.419 | 0.558 | 0.698 | 0.837 | 0.977 | 1.117 | 1.257 | 1.397 | 1.545 |
| 90 (32) | 0.069 | 0.207 | 0.345 | 0.483 | 0.621 | 0.759 | 0.897 | 1.035 | 1.173 | 1.311 | 1.462 |
| 100 (38) | 0.000 | 0.137 | 0.273 | 0.409 | 0.546 | 0.682 | 0.818 | 0.955 | 1.094 | 1.230 | 1.371 |

TABLE 8 — HOT WATER OUTPUT, FLOW RATE AND PRESSURE LOSS FACTORS BASED ON STANDARD CONDITIONS OF 200°F (93°C) ENTERING WATER, 60°F (16°C) ENTERING AIR & 20°F (11°C) WATER DROP

| USE FACTORS FROM THIS TABLE TO OBTAIN APPROXIMATE RESULTS | TEMPERATURE DROP °F (°C) | | | | | | | | | |
|--|--------------------------|-----------|-----------|------------|------------|------------|------------|------------|------------|--|
| | 5 (3) | 10 (6) | 15 (8) | 20 (11) | 25 (14) | 30 (17) | 40 (22) | 50 (28) | 60 (33) | |
| To obtain output for other Water Temperature Drops, multiply basic output rating by applicable Factor. | 1.25 | 1.15 | 1.08 | 1.00 | .94 | .90 | .83 | .76 | .72 | |
| To obtain flow for other Water Temperature Drops, multiply basic rate rating by applicable Factor.* | 5.00 | 2.30 | 1.44 | 1.00 | .74 | .59 | .40 | .30 | .24 | |
| To obtain Pressure Loss Feet (Meters) of Water for other temperature Drops, multiply Basic loss at 20°F (11°C) drop by Factor. | 10.00 | 5.00 | 2.00 | 1.00 | .60 | .40 | .20 | .13 | .07 | |

***TABLE 9 — MINIMUM WATER FLOW**

| | | | | | | | | | | | | |
|-------------------|-----------------|-----------------|-----------------|-----------------|-----------------|-----------------|-----------------|-----------------|-----------------|-----------------|-----------------|-----------------|
| MODEL No. | 108A | 118A | 125A | 136A | 18 | 24 | 36 | 48 | 60 | 72 | 84 | 96 |
| MINIMUM GPM (L/s) | 0.125 (.008) | 0.125 (.008) | 0.125 (.008) | 0.125 (.008) | 0.750 (.047) | 1.240 (.078) | 1.240 (.078) | 1.490 (.094) | 1.490 (.094) | 1.620 (.102) | 1.860 (.117) | 3.350 (.211) |
| MODEL No. | 108 | 120 | 132 | 144 | 156 | 180 | 204 | 240 | 280 | 300 | 360 | |
| MINIMUM GPM (L/s) | 3.35 (.211) | 3.60 (.227) | 4.09 (.258) | 4.09 (.258) | 4.09 (.258) | 4.34 (.274) | 4.34 (.274) | 4.59 (.290) | 4.59 (.290) | 6.08 (.384) | 6.08 (.384) | |

***TABLE 10 — HEATING CAPACITY FACTORS FOR VARIOUS RATES OF WATER FLOW**

| | | | | | | | |
|-------------------------|-----|-----|-----|------|------|------|------|
| % of Rated Water Flow | 25% | 50% | 75% | 100% | 125% | 150% | 175% |
| Heating Capacity Factor | .80 | .89 | .96 | 1.00 | 1.04 | 1.07 | 1.10 |

TECHNICAL DATA

The performance data listed in Table 6 includes sound ratings. The ratings provide a guide in determining the acceptable degree of loudness in particular occupancy situations.

Certain general rules apply to specific selection of unit heaters with regard to degree of quietness (or loudness);

- The greater the fan diameter, the higher the sound level.
- The higher the motor RPM, the higher the sound level. Note that on most units the lower the speed mode results in lowering the sound rating one increment.
- Selecting a larger number of smaller units generally results in lower overall noise levels than fewer large units.

All horizontal steam and hot water unit heater motors, whether fan guard or shelf-mounted, are isolated from the mechanical mount by resilient isolators. This mounting along with balanced fan blades and excellent overall construction integrity, assures you the utmost in quiet operation.

The following table outlines sound ratings for various applications. The lower the number, the quieter the unit and the lower the sound requirement.

| CATEGORY OF AREA | SOUND RATING |
|---|--------------|
| Apartment, assembly hall, classrooms, churches, courtrooms, executive offices, hospitals, libraries, museums, theatres. | I |
| Dining rooms, general offices, recreation areas, small retail stores. | II |
| Restaurants, banks, cafeterias, department stores, public buildings, service stations. | III |
| Gymnasiums, health clubs, laundromats, supermarkets. | IV |
| Garages, small machine shops, light manufacturing. | V |
| Factories, foundries, steel mills. | III - VII* |

*Depending on specific use in these facilities, size of operation, etc.

CORRECTIONS WHEN USING GLYCOL SOLUTION IN SYSTEM

| | Propylene Glycol | Propylene Glycol |
|--|--|---|
| 1. Heat transfer @ 180°F (82°C) with no increase in flow rate | 20% solution .97* 50% solution .90* | 7. Freezing Point 55% by volume - 50% -28°F (-33°C) 40% -13°F (-25°C) 30% + 4°F (-16°C) 20% +17°F (- 8°C) |
| 2. G.P.M. Req'd. @ 180°F (82°C), 20°F (11°C) Δ t (no correction to pump curve) | 1.10%* | *Compared to water. |
| 3. Pump Head Req'd. @ 180°F (82°C) w/increase in G.P.M. | 1.23%* | |
| 4. Specify gravity (water = 1.0) | 1.045-1.055* | |
| 5. Pounds/Gallons @ 60°F (16°C) (water = 8.3453 Pound/Gallon) | 8.77 | |
| 6. pH @ 50% by volume | 9.5 | |

| Approximate factors at varying altitudes | |
|--|--------|
| Altitude | Factor |
| Sea level - 1000 ft. (305m) | 1.00 |
| 1000 ft. - 3000 ft. (915m) | .958 |
| 3000 ft. - 5000 ft. (1524m) | .929 |
| 5000 ft. - 7000 ft. (2134m) | .900 |
| 7000 ft. - 10000 ft. (3048m) | .871 |

MOTOR DATA

NOTE 1: All motors are constant speed and operate at top speed as indicated in motor data. Models 18 through 108, including 108A, 118A, 125A and 136A can be run at reduced speed with addition of optional variable speed switch. This switch is factory-calibrated for low and high speed ratings, with intermediate speeds infinitely controllable. Models 120 through 360 operate at constant speed as indicated in motor data. All 1/4 H.P. motors are P.S.C.

NOTE 2: Motors under 1/3 H.P. are totally enclosed, frame mounted, 115/1/60 with thermal overload protection and permanently lubricated sleeve bearings with optional speed controller available. 1/3 H.P. (115/1/60) motors are open frame constant speed with thermal over-load protection and ball bearings. 1/3 H.P. (230V) and 1/2 H.P. (230V) motors are open frame constant speed with thermal overload protection and ball bearings.

NOTE 3: 1/3 and 1/2 H.P. motors are available as 230V single and 3 phase in open frame and explosion-proof housings, all available as options. 1/3 and 1/2 H.P. motors operate at single speed only.

NOTE 4: Stated AMP draw is Full Load Amp (FLA). AMP draw varies by motor manufacturer ± 0.2 AMPS. Verify FLA per unit motor data plate.

▲ CAUTION Select appropriate AMP, MCA, and MOP for the multiple voltage motors. For example, the AMP, MCA, and MOP for Models 360 with a 460 volt Totally Enclosed motor is 1.3, 1.6 and 2.9 respectively.

NOTICE: Also refer to Maintenance section for additional motor data.

Table 11 - TOTALLY ENCLOSED MOTOR TYPE

| Unit Model No. | AMP | MCA | MOP | HP | RPM |
|---|-------------|-------------|-------------|-------|------|
| 115/1/60 | | | | | |
| 18, 24, 108A, 118A | 0.8 | 1 | 1.8 | 16W* | 1550 |
| 136A | 1.4 | 1.8 | 3.2 | 1/20* | 1000 |
| 36, 125A | 1.2 | 1.5 | 2.7 | 25W* | 1550 |
| 48, 60, 72 | 1.4 | 1.8 | 3.2 | 1/20* | 1000 |
| 84, 96, 108 | 2.2 | 2.8 | 5.0 | 1/12* | 1000 |
| 120, 132, 144, 156, 180, 204, 240 | 4.5 | 5.6 | 10.1 | 1/3 | 1140 |
| 280, 300, 360 | 5.4 | 6.8 | 12.2 | 1/2 | 1100 |
| 230/1/60 | | | | | |
| 18, 24, 108A, 118A | 0.4 | 0.5 | 0.9 | 16W | 1550 |
| 136A | 1.4 | 1.8 | 3.2 | 1/20† | 1000 |
| 36, 125A | 0.6 | 0.8 | 1.4 | 25W | 1550 |
| 48, 60, 72 | 1.4 | 1.8 | 3.2 | 1/20† | 1000 |
| 84, 96, 108 | 2.2 | 2.8 | 5.0 | 1/12† | 1000 |
| 120, 132, 144, 156, 180, 204, 240 | 4.5 | 5.6 | 10.1 | 1/3† | 1140 |
| 280, 300, 360 | 5.4 | 6.8 | 12.2 | 1/2† | 1100 |
| 208-230/460/3/60 | | | | | |
| 48, 60, 72, 84, 96, 108, 120, 132, 144, 156, 180, 204, 240, 280, 300, 360 | 2.6-2.6/1.3 | 3.3-3.3/1.6 | 5.9-5.9/2.9 | 1/2** | 1140 |

*Optional variable speed switch is available.

**These motors are without thermal overload protection.

†230/1/60 unit has 115/1/60 motor supplied with field installed stepdown transformer.

Table 12 - EXPLOSION PROOF WITH THERMAL OVERLOAD MOTOR TYPE

| Unit Model No. | AMP | MCA | MOP | HP | RPM | AMP | MCA | MOP | HP | RPM |
|-----------------------------------|---------|----------|-----------|--------|------|---------------------|---------|---------|-----|------|
| 115-230/1/60 | | | | | | 230/460/3/60 | | | | |
| 48, 60, 72, 84, 96, 108, 120, 132 | 3.7 | 4.6 | 8.3 | 1/6† | 1140 | — | — | — | — | — |
| 144, 156, 180, 204 | 5.4 | 6.8 | 12.2 | 1/4† | 1140 | 2.2/1.1 | 2.8/1.4 | 5.0/2.5 | 1/3 | 1140 |
| 240, 280, 300 | 7.4/3.7 | 9.3/4.7 | 16.7/8.3 | 1/3*** | 1140 | 2.2/1.1 | 2.8/1.4 | 5.0/2.5 | 1/3 | 1140 |
| 360 | 9.6/4.8 | 12.0/6.0 | 21.6/10.8 | 1/2*** | 1140 | 2.2/1.1 | 2.8/1.4 | 5.0/2.5 | 1/3 | 1140 |

***These motors are 115/230 volts.

†230/1/60 unit has 115/1/60 motor supplied with field installed stepdown transformer.

LOCATION

It is assumed that the design engineer has selected, sized, and located in the area to be heated. However, the information given here may be of additional help to the installer. These sketches indicate suggested basic locations for different types of unit heaters.

Horizontal unit heaters should be located to give a circulatory motion, preferably in the outer perimeter of the building. The units should be spaced to properly blanket the areas with warm air.

The unit should be suspended from connections provided in the unit by means of rods. The rods should then be attached to solid supports of the building.

Figure 5

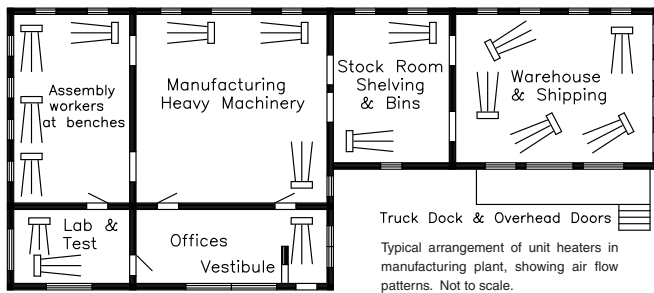

Figure 6
MOUNTING HEIGHT AND
APPROX. HEAT THROW

Based on 2 PSI (13.8 kPa) steam pressure and 60°F (16°C) entering air temperature

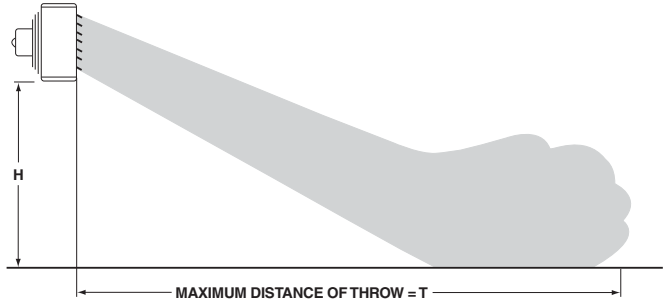
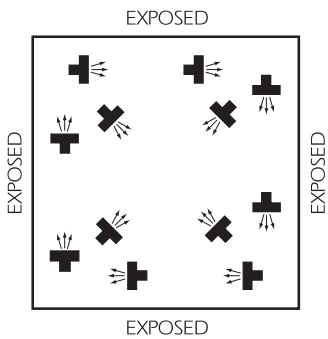

Table 13

| Model No. | Maximum Mounting HT. ft (m) | Approx. Max. Throw ft (m) |
|-----------|-----------------------------|---------------------------|
| 108A | 8 (2.4) | 20 (6.1) |
| 118A | 8 (2.4) | 25 (7.6) |
| 125A | 9 (2.7) | 29 (8.8) |
| 136A | 9 (2.7) | 29 (8.8) |
| 18 | 8 (2.4) | 20 (6.1) |
| 24 | 8 (2.4) | 24 (7.3) |
| 36 | 9 (2.7) | 28 (8.5) |
| 48 | 9 (2.7) | 30 (9.1) |
| 60 | 10 (3.0) | 30 (9.1) |
| 72 | 10 (3.0) | 29 (8.8) |
| 84 | 10 (3.0) | 30 (9.1) |
| 96 | 11 (3.4) | 38 (11.6) |
| 108 | 11 (3.4) | 40 (12.2) |
| 120 | 12 (3.7) | 40 (12.2) |
| 132 | 13 (4.0) | 54 (16.5) |
| 144 | 13 (4.0) | 55 (16.8) |
| 156 | 13 (4.0) | 55 (16.8) |
| 180 | 13 (4.0) | 53 (16.2) |
| 204 | 13 (4.0) | 55 (16.8) |
| 240 | 14 (4.3) | 57 (17.4) |
| 280 | 14 (4.3) | 57 (17.4) |
| 300 | 15 (4.6) | 58 (17.7) |
| 360 | 15 (4.6) | 60 (18.3) |



A large square area with exposed walls and roof; units are blanketing all exposed surfaces.

A narrow area with two exposed walls either with or without roof exposure.

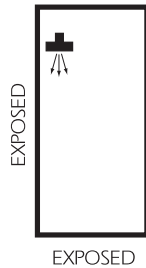

A small area with exposed walls requiring one unit.

INSTALLATION

UNIT MOUNTING

Install unit heaters to meet Occupational Safety and Health Act (OSHA) and ETL requirements. Unit heaters mounted lower than 8 feet (2.4m) from the floor must be equipped with an OSHA fan guard.

NOTICE: Units equipped with the motor mounted to the fan guard require two point suspension. Units equipped with a shelf mounted motor are required to be suspended at four points. Refer to Figures 3 and 4 for two point suspension and refer to Figure 6A for four point suspension.

▲ CAUTION Unit heaters must be hung level from side to side and from front to back. Failure to do so will result in poor performance and/or premature failure of the unit.

▲ WARNING Make certain that the lifting methods used to lift the heater and the method of suspension used in the field installation of the heater are capable of uniformly supporting the weight of the heater at all times. Failure to heed this warning may result in property damage or personal injury!

▲ WARNING Insure that all hardware used in the suspension of each unit heater is more than adequate for the job. Failure to do so may result in extensive property damage, severe personal injury, or death!

▲ WARNING Make sure that the structure to which the unit heater is to be mounted is capable of safely supporting its weight. Under no circumstances must the water lines or the electrical conduit be used to support the heater; or should any other objects (i.e. ladder, person) lean against the heater water lines or the electrical conduit for support. Failure to heed these warnings may result in property damage, personal injury, or death.

Nutserts are provided at the top of all units for suspension purposes. Support rods should support the total unit weight to assure that no strain is placed on supply and return piping. Provisions for removal of the unit from the suspension rods may be desirable for servicing purposes.

Units must hang level vertically and horizontally.

Provide sufficient clearance around units for maintenance purposes.

Isolators are not required but may be desirable for some applications. Refer to "Dimensional Data" in Tables 1 and 2.

PIPING

To provide proper coil operation, follow all piping recommendations listed in this manual.

See Figures 7 through 11 for proper pipe connections.

Follow standard practices and codes when installing the piping. Provide swing joints for expansion purposes, unions and shut-off valves for servicing purposes and as illustrated in Figures 7 through 11, valves and traps for control purposes. Use 45 degree angle run-offs from all supply and return mains.

Dirt pockets should be the same pipe size as the return tapping of the unit heater. Also, pipe size in the branch-off should be the same size as the tapping in the traps. Beyond the trap, the return lateral pipe should be increased one size up to the return main.

It is assumed that the design engineer has selected the type of system to be used. The sketches shown are for different types of steam systems or hot water systems. For sizing of piping, traps, filter, etc., consult ASHRAE guides of the manufacturer's literature on these products.

It is important that the system be kept clean. Care should be exercised that excessive joint materials or foreign substances be kept out of the system.

On steam systems it is recommended that the unit be installed level for proper condensate drainage. Swing joints should be used in piping, and pipes should be pitched down from units so that condensate can drain freely.

Figure 6A
Four Point
Suspension -
Shelf Mounted
Motors Only

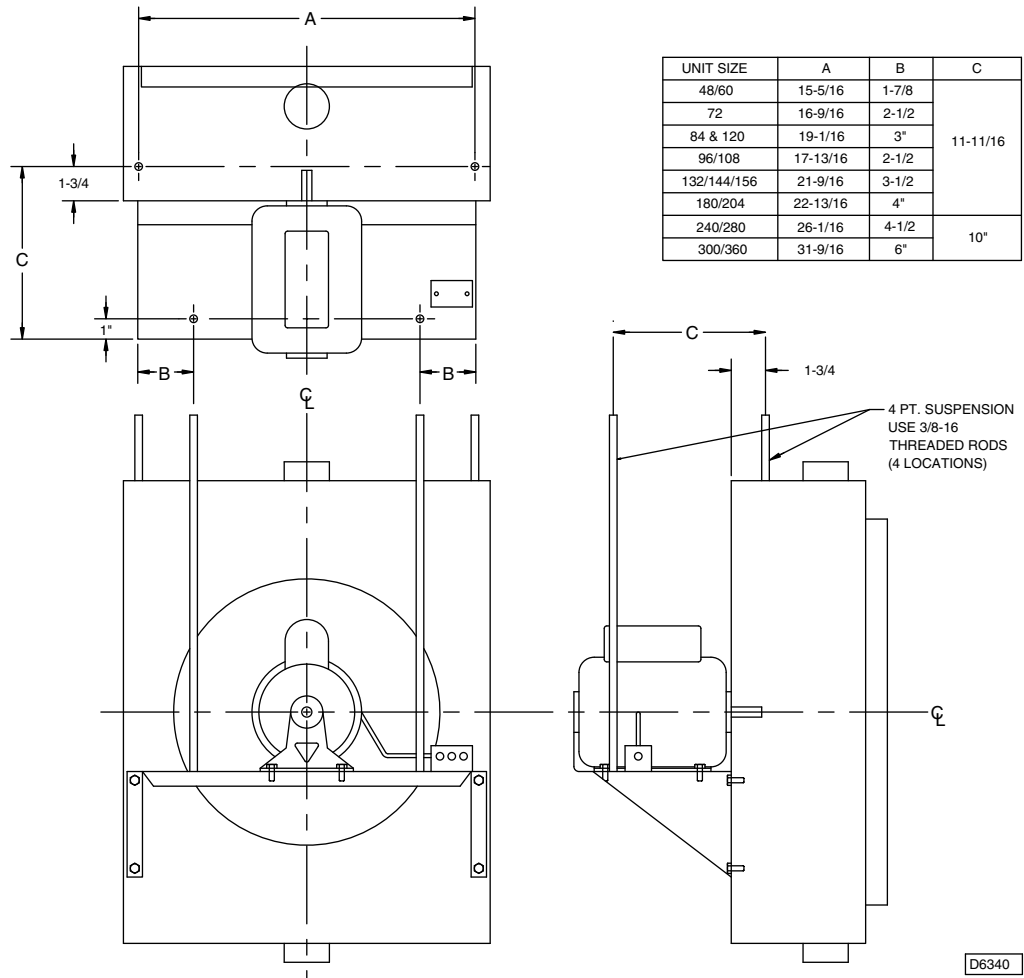

Figure 7
Forced
Hot Water

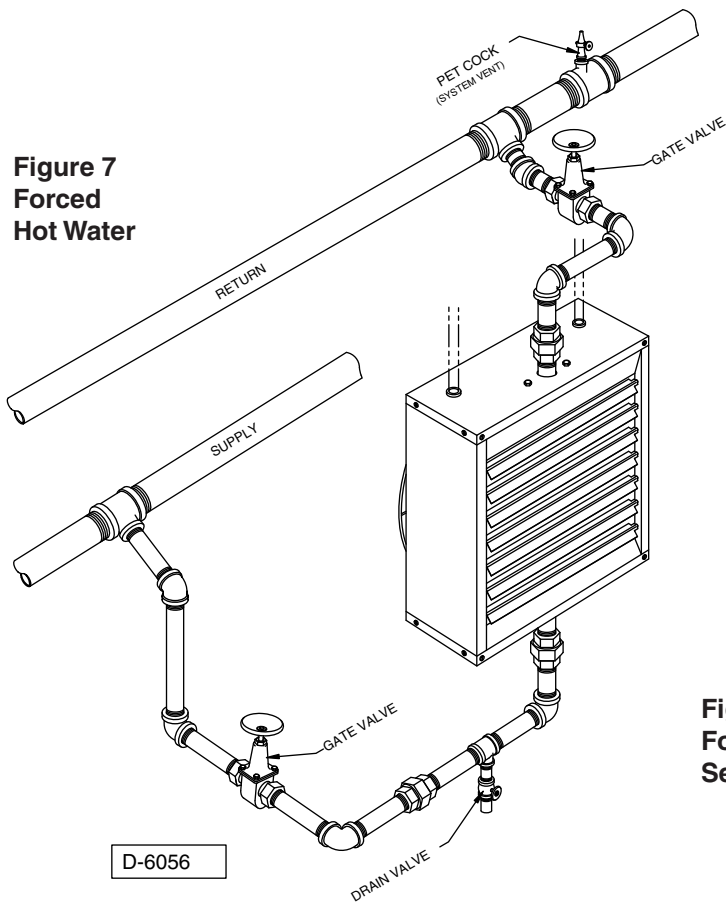

Figure 8
Forced Hot Water
Serpentine Unit Only

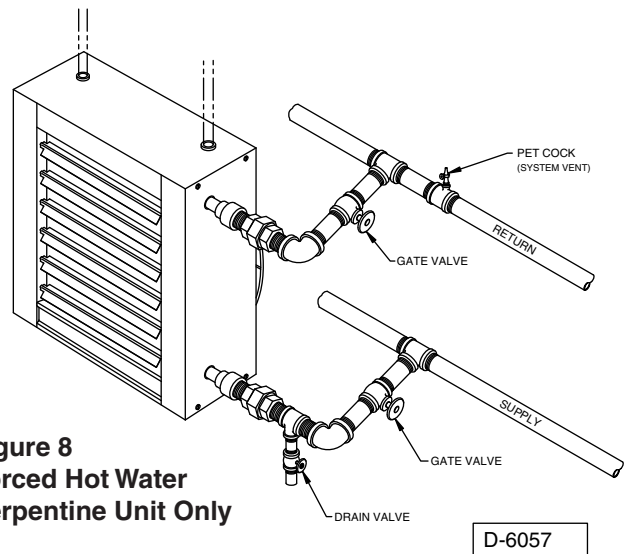

Figure 9
High Pressure
Steam

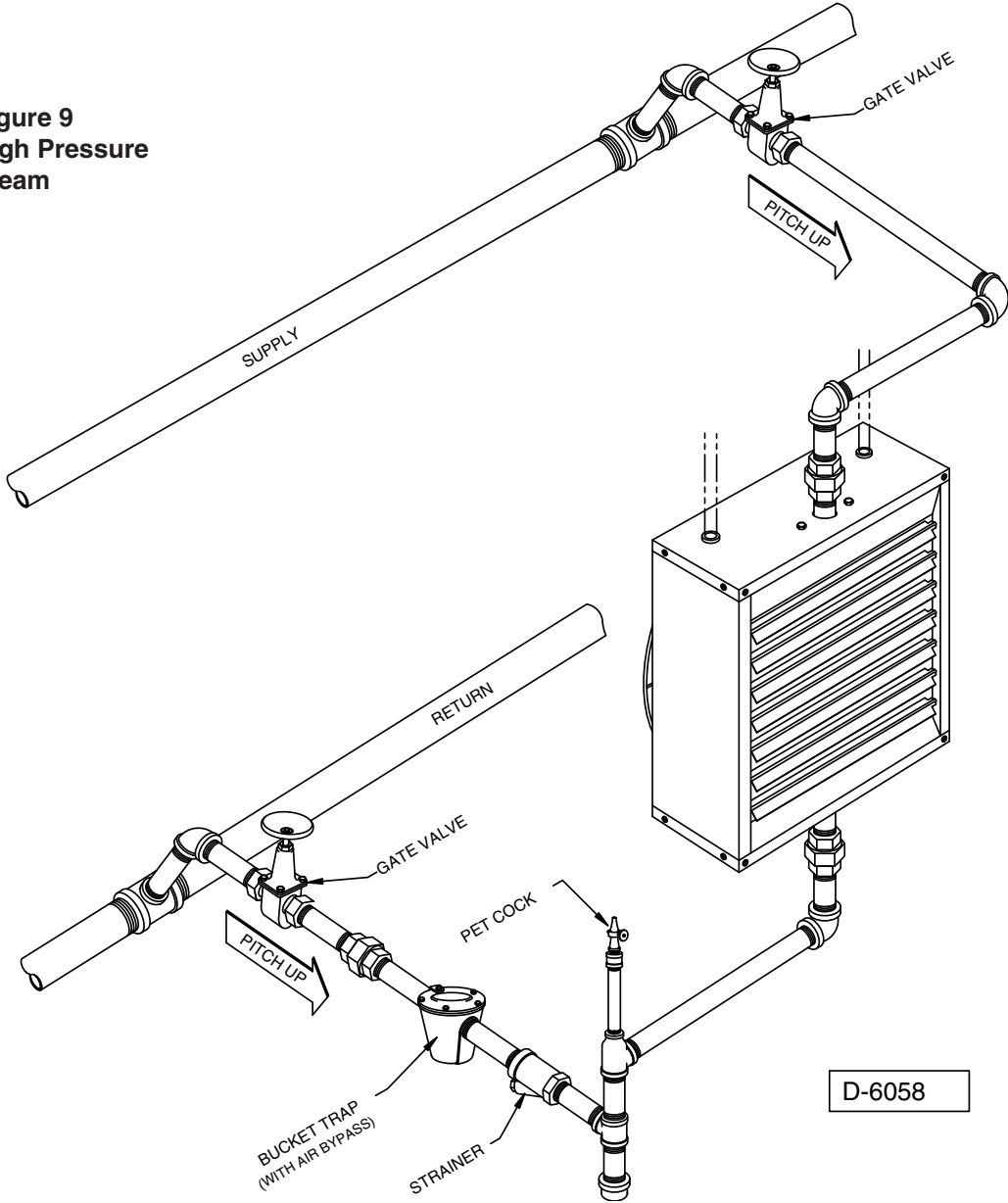

Figure 10
Low Pressure
Steam Gravity

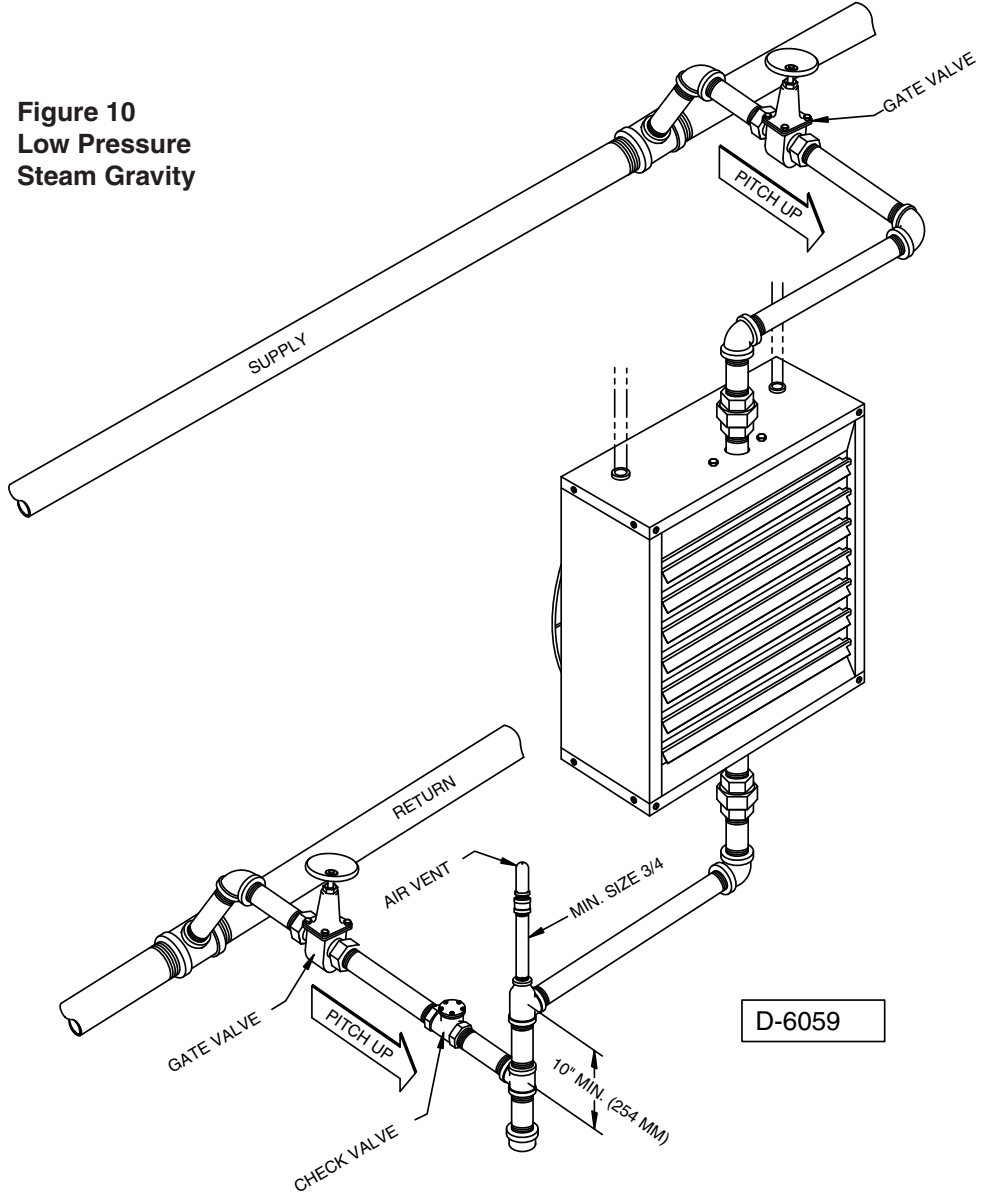
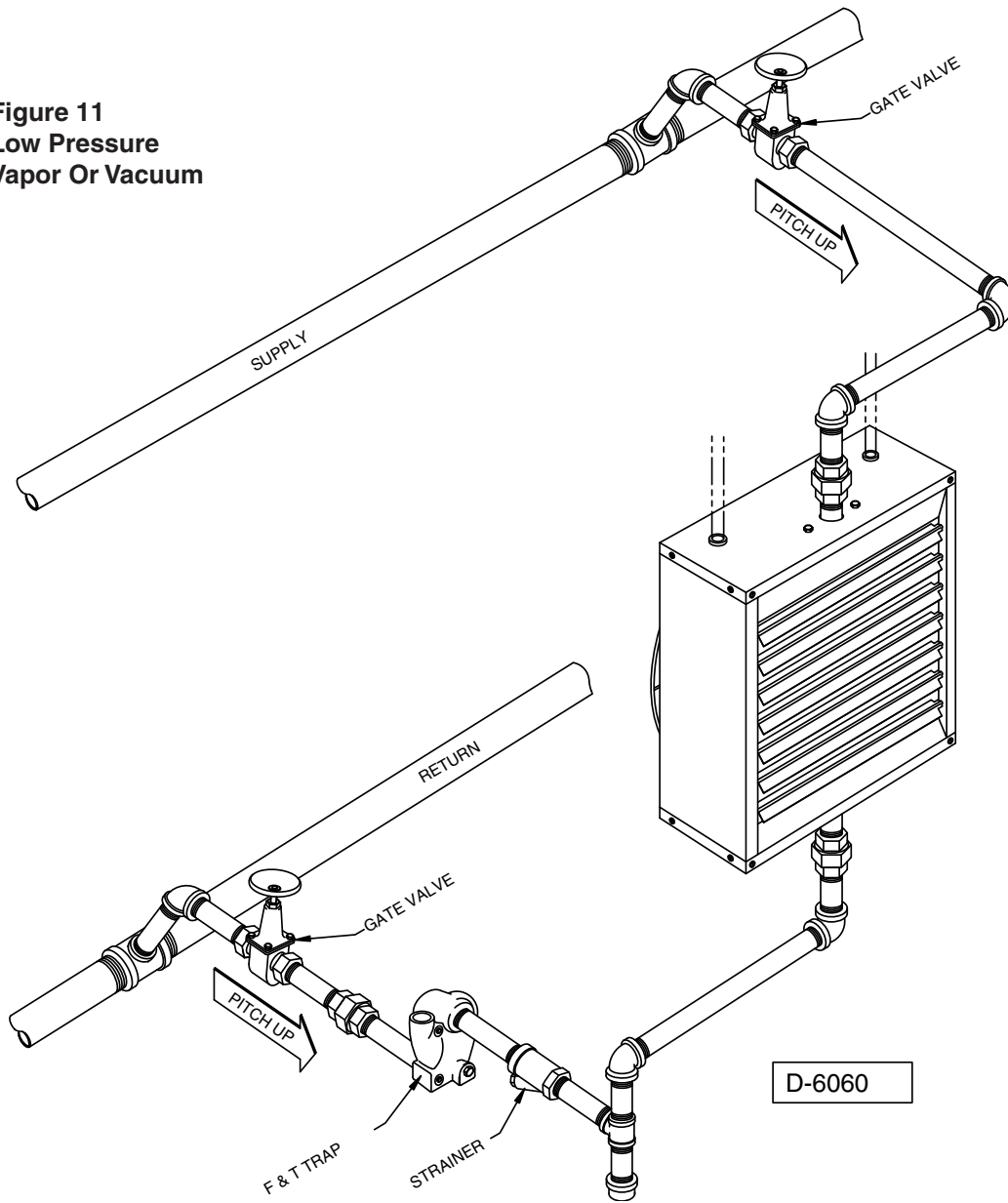



Figure 11
Low Pressure
Vapor Or Vacuum



ELECTRICAL CONNECTIONS

| | |
|---|--|
|  | <p>▲ WARNING</p> <p>HAZARDOUS VOLTAGE! DISCONNECT ALL ELECTRIC POWER INCLUDING REMOTE DISCONNECTS BEFORE SERVICING. Failure to disconnect power before servicing can cause severe personal injury or death.</p> |
|---|--|

Standard units are shipped for use on 115 volt, 60 hertz single phase electric power. The motor nameplate and electrical rating on the transformer should be checked before energizing the unit heater electrical system. All external wiring must conform to ANSI/NFPA No. 70-2006, National Electrical Code (or the latest edition) and applicable current local codes; in Canada, to the Canadian Electrical Code, Part 1 CSA Standard C22.1.

▲ CAUTION Do not use any tools (i.e. screwdriver, pliers, etc.) across the terminals to check for power. Use a voltmeter.

It is recommended that the electrical power supply to each unit heater be provided by a separate, fused and permanently live electrical circuit. A disconnect switch of suitable electrical rating for each unit heater should be located as close to the controls as possible. Each unit heater must be electrically grounded in accordance with National Electric Code, ANSI/NFPA No. 70-2006 (or the latest edition) or CSA Standard C22.1. Sample wiring connections are depicted in Figures 12 through 22.

OPERATION

Most basic unit heater systems are controlled by a room thermostat. Locate thermostat on inner wall or column so that optimum control can be obtained for that area. Set thermostat for desired temperature.

On steam systems a low limit may be used to prevent fan from blowing cold air unless the heater has steam passing through the coil.

Small hot water systems could have the circulating pump controlled directly by the room thermostat. On large systems, zone valves could be used to control the individual unit heater where constant water circulation is used on the main system.

Horizontal louvers are standard equipment on horizontal unit heaters, vertical louvers are available as an optional accessory.

THERMOSTAT WIRING AND LOCATION

NOTICE: The thermostat must be mounted on a vertical vibration-free surface free from air currents and in accordance with the furnished instructions.

Mount the thermostat approximately 5 feet (1.5 m) above the floor in an area where it will be exposed to a free circulation of average temperature air. Always refer to the thermostat instructions as well as our unit wiring diagram and wire accordingly. Avoid mounting the thermostat in the following locations:

1. Cold areas - Outside walls or areas where drafts may affect the operation of the control.
2. Hot areas - Areas where the sun's rays, radiation, or warm air currents may affect control operation.
3. Dead areas - Areas where air cannot circulate freely, such as behind doors or in corners.

NOTICE: For all wiring connections, refer to the wiring diagram on the motor nameplate (also refer to page 18). Should any original wire supplied with the heater have to be replaced, it must be replaced with wiring material having a temperature rating of at least 105° C.

WIRING INSTALLATION

Figure 12

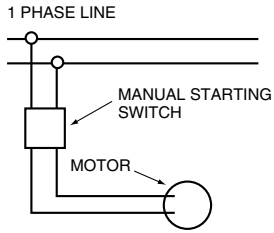

MANUAL CONTROL WITH SINGLE PHASE MOTOR

Figure 13

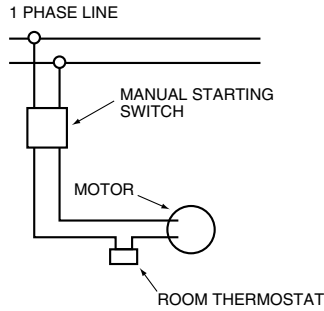

THERMOSTATIC CONTROL WITH MANUAL STARTER

Figure 14

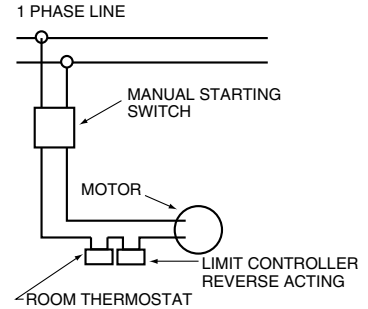

THERMOSTATIC CONTROL WITH REVERSE ACTING CONTROLLER AND MANUAL STARTER

Figure 15

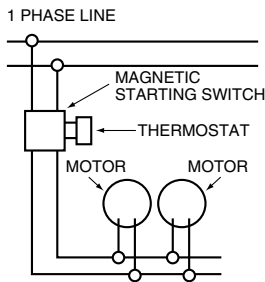

THERMOSTATIC CONTROL USING MAGNETIC STARTER OPERATING SEVERAL UNITS

Figure 16

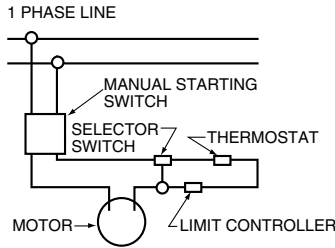

THREE POSITION SELECTOR SWITCH USED FOR EITHER MANUAL OR THERMOSTATIC CONTROL

Figure 17

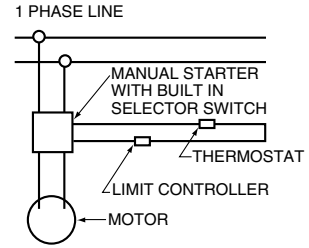

THREE POSITION SELECTOR SWITCH BUILT INTO MAGNETIC STARTER FOR MANUAL OR THERMOSTATIC CONTROL

Figure 18

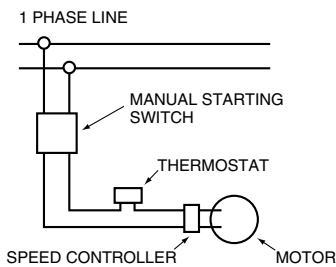

SPEED CONTROLLER WITH MANUAL STARTING SWITCH

Figure 19

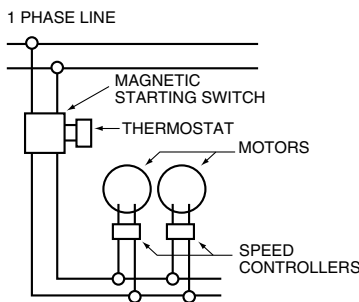

SPEED CONTROLLERS WITH MAGNETIC STARTING SWITCH FOR OPERATING SEVERAL UNITS

Figure 20

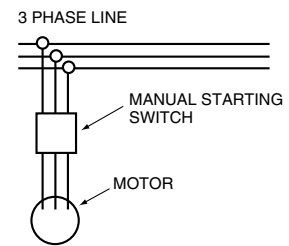

MANUAL CONTROL WITH THREE PHASE MOTOR

Figure 21

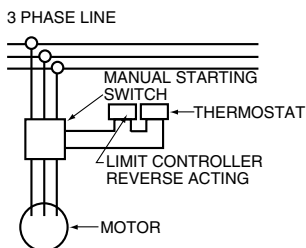

THERMOSTATIC CONTROL WITH LIMIT CONTROLLER FOR THREE PHASE MOTOR

Figure 22

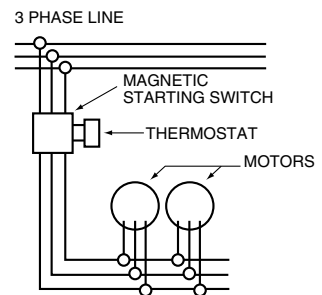

THERMOSTATIC CONTROL OF SEVERAL THREE PHASE UNITS

NOTICE

1. When using a speed controller, always locate the thermostat between the speed controller and the line, not between the motor and the controller.
2. For internal wiring and overload protection on all starters, consult the control manufacturer for details.
3. When using thermostatic control with a manual starter, be sure that the electrical rating of the thermostat is sufficient to carry the motor current.

OPTIONS

VARIABLE SPEED CONTROL

115 Volt Only (optional)

The solid state speed controller may be installed at any convenient location and is suitable for surface or flush type mounting. A Standard electrical single or double gang wall box is recommended as in Figure 23.

Figure 23
Wiring Diagram of Speed Control Installation

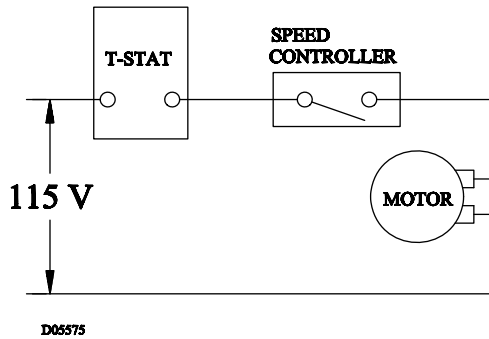

Installation procedure:

1. Attach the control's leads to the electrical leads in the control box using wire nuts. The speed control is to be wired in series with the motor. See wiring diagram in Figure 23.
2. Make certain wire nuts are tight with no copper wire being exposed.
3. Place wires and wire nuts back into box allowing room for the control to fit in box also.
4. Mount speed control to box using number 6 flathead screws provided.

Setting the control:

1. Turn the control shaft fully clockwise. If the motor is not running at the desired low speed, adjust the trim on the face of the control for low speed setting using a small screwdriver.
2. Rotate the control shaft counter clockwise. The speed will increase smoothly from minimum to maximum and then switch off.
3. Mount face plate with screw provided and attach control knob.

STRAP-ON WATER CONTROL

A SPDT strap-on type hot water control with 100° to 240°F (38 to 116°C) rated at 10 amps at 120V is also available. Control can be used for direct or reverse acting applications as high or low limit.

STEAM PRESSURE CONTROL

SPDT switch opens on a rise in pressure. Control is automatically reset, has a range of 0 to 15 PSIG (0 to 103 kPa) and has an adjustable differential. **Other actions, ranges, circuits and manual reset models are available on request.**

HORIZONTAL AND VERTICAL LOUVERS

Horizontal louvers are standard on all models. Vertical louvers are an optional accessory on all models. Vertical louvers are installed on built to order units or shipped loose for field installation.

Figure 24
Horizontal and Vertical Louver Mounting

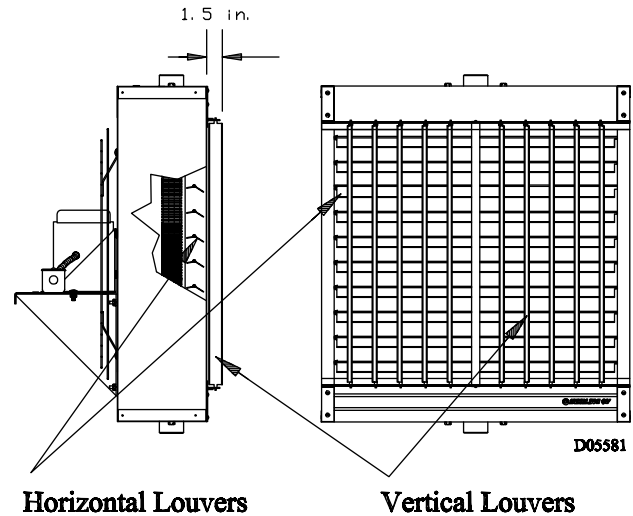

THERMOSTATS

Line voltage wall thermostats are in stock for immediate shipment. All models are SPST with bimetal thermometer, knob-type set point adjustment, 40 to 90°F (5 to 30°C) range and selector switches. Standard duty models with "off-auto" and "auto-off-fan" and a heavy duty model with "auto-off-fan" switching are available. Other models available on request. Plastic tamperproof one size fits all thermostat guards are also available.

MANUAL STARTERS

Single and three-phase models are available. Standard models are single-speed, toggle-operated, NEMA Type 1 and are surface-mounted.

WALL MOUNTED SPEED CONTROLLERS

Units with standard motors up to Model 108 (115/1/60) can be operated at reduced speeds by addition of optional speed controller. Controller is 5 amps, pre-set at factory for maximum and minimum speeds, with intermediate speeds infinitely controllable. All 1/3, 1/2 HP and 230V motors operate only at rated speed and CFM – See Charts.

NOTICE: When using electrical accessories, always refer to the accessory manufacturer's installation manual for proper use, location and wiring instructions.

MAINTENANCE

PERIODIC SERVICE

▲ WARNING Open all disconnect switches and secure in that position before servicing unit. Failure to do so may result in personal injury or death from electrical shock.

Because of the simple design of the steam and hot water unit heaters, they are nearly maintenance free. However, depending on the environment, simple maintenance practices should be adopted.

Periodically check the finned surfaces and vacuum these as often as necessary to remove any accumulation of lint and dirt. Check fan blades and remove dirt accumulation. If fan blades are not cleaned they tend to become unbalanced.

Most of the motors supplied on the unit heaters have either ball bearings or sleeve bearings and should not require lubrication for long periods of time. It is however advisable that motor maintenance and lubrication recommended by the motor manufacturer be followed.

Check motors for dirt and dust accumulation, and remove any accumulation as often as necessary. Open type motors may overheat if the dirt or dust is not removed from ventilation openings.

▲ CAUTION Allow rotating fans to stop before servicing to avoid serious injury to fingers and hands.

MOTOR LUBRICATION

Sleeve Bearings

Motors with oilers or oil holes are lubricated before shipment with a good grade of electric motor oil. Refill when necessary, with the motor at a stand-still, until oil reaches the proper level.

Use SAE 20W non detergent oil for motors operating in ambient temperatures of 32°F to 100°F (0°C to 38°C). Below 32°F (0°C), SAE 10W non detergent oil will be required.

The frequency of oiling will depend upon operating conditions and length of running time. Inspect the oilers or oil holes when cleaning the unit. If the unit has a fractional horse-power motor, lubricate at least once a year. Under high ambient conditions or constant fan operation, fractional horse-power motors should be lubricated every 90 days. On those motors without oilers or oil holes, follow the instructions given on the motor nameplate.

Ball Bearings

Ball bearing motors are pre-lubricated and normally not equipped with grease fittings. However, motors are equipped with removable grease plugs to allow installation of grease fittings if desired by owner. Motor manufacturers do not recommend or require on the job lubrication of ball bearing motors.

If on the job lubrication is required by the owner, use the following procedure: With the motor at a stand-still, remove the vent and grease plugs. Install grease fitting and add grease sparingly. Remove the old grease from the vent relief chamber. Operate the motor a few minutes before reinstalling the vent plug to allow excess grease to escape. If there is evidence of grease working out around the motor shaft, less grease should be added and the greasing periods lengthened. If grease continues to appear, take the motor to the motor manufacturer's authorized service station for repair.

NOTICE: Consult local motor manufacturer's service facility for information on type of grease and oil to be used.

NOTICE: The heater system should be checked once a year by a qualified technician. All maintenance/service information should be recorded accordingly on the inspection sheet provided in this manual.

Should maintenance be required, perform the following inspection and service routine:

CLEANING THE UNIT

The unit casing, fan, diffuser and coil should be cleaned thoroughly once a year. Coil heat transfer efficiency depends on cleanliness. The following recommended procedures may be performed when lubricating the motor and cleaning the coil.

1. Wipe all excess lubricant from the motor, fan and casing. Clean the motor thoroughly. A dirty motor will run hot and eventually cause internal damage.
2. Clean the coil:
 - a) Loosen the dirt with a brush on the fan side of the coil. Operate the motor allowing the fan to blow the loosened dirt through the unit.
 - b) Use high pressure air or steam on the side of the coil away from the fan.

NOTICE: A piece of cheesecloth or a burlap bag may be used to collect the large particles during the cleaning process.

3. Clean the casing, fan blades, fan guard and diffuser using a damp cloth. Any rust spots on the casing should be cleaned and repainted.
4. Tighten the fan guard, motor frame and fan bolts. Check the fan for clearance in the panel orifice and free rotation.

REPLACEMENT PARTS

When ordering replacement parts
 Model, Model Type (IE: Standard or Exp. Proof), Size & Item Numbers must be specified
 Consult factory for price and availability

Figure 25
 Horizontal Steam
 Unit Heaters

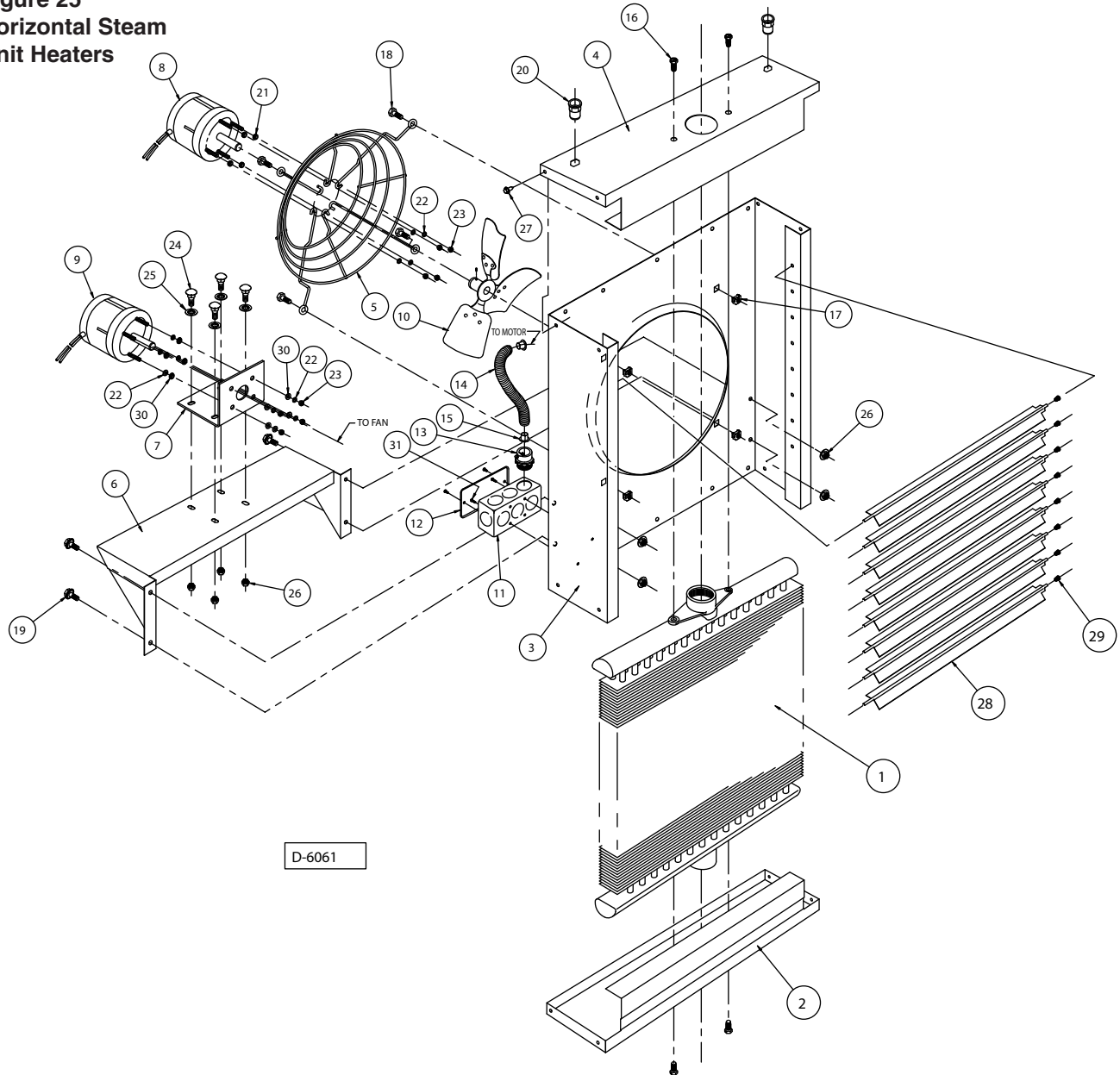

HORIZONTAL STEAM UNIT HEATER PARTS

- | | | |
|---|--|------------------------------|
| 1 - Element (1) | 10 - Fan (1) | 21 - Grommet (4) |
| 2 - Bottom Jacket Panel (1) | 11 - Junction Box (1) | 22 - Washer, Flat (4) |
| 3 - Venturi Jacket Panel (1) | 12 - Junction Box Cover (1) | 23 - Nut (4) |
| 4 - Top Jacket Panel (1) | 13 - Connector (1) | 24 - Bolt (4) |
| 5 - Motor Mount & Fan Guard* [Std. Unit Shown] | 14 - Conduit, Flex (1) | 25 - Washer, Spring Lock (8) |
| 6 - Motor Mounting Bracket [3 Phase and/or Explosion Proof]* | 15 - Anti-Short (2) | 26 - Nut (8) |
| 7 - Motor Mounting Angle [3 Phase and/or Explosion Proof]* (1) | 16 - Screw (4) | 27 - Screw (2) |
| 8 - Motor [Std. Units]* | 17 - Nut Retainer (4) | 28 - Louvers (Horiz) |
| 9 - Motor [3 Phase and/or Explosion Proof]* | 18 - Bolt (3) Models 24 & 36, (4) Models 48/204 | 29 - Cone Spring |
| | 19 - Flange Screw | 30 - Grommet, Stem (4) |
| | 20 - Threaded Inserts | 31 - Screw (18) |

() = Qty Req'd per unit *Select One

Table 14 - Troubleshooting Guide

| SYMPTOMS | POSSIBLE CAUSE(S) | CORRECTIVE ACTION |
|---------------------------------------|---|--|
| A. Leaking coil. | <ol style="list-style-type: none"> 1. Frozen coil. 2. Defective coil. 3. Corrosion. 4. Leak in joint. | <ol style="list-style-type: none"> 1. Replace. 2. Replace. 3. Replace 4. Braze joint if joint is exposed where leak has occurred. |
| B. Poor output on steam. | <ol style="list-style-type: none"> 1. Check for air in coil. 2. Lint on coil fins. | <ol style="list-style-type: none"> 1. Repair or replace thermostatic air vent. 2. Clean coil and fins. |
| C. Poor output on steam or hot water. | <ol style="list-style-type: none"> 1. No circulation of water through coil. 2. Short cycling of motor. 3. Backward rotating motor. | <ol style="list-style-type: none"> 1. Check circulation pump. Check for blocked tubes. 2. Check voltage and correct. Check for linted coil and clean. Check for defective overload and repair or replace motor. 3. On single phase motor replace motor. On three phase motor, reverse two leads to change rotation. |
| D. Noisy or vibrating unit. | <ol style="list-style-type: none"> 1. Damaged fan blade. 2. Dirty fan blade. | <ol style="list-style-type: none"> 1. Change fan blade. 2. Clean fan blade. |

HOW TO ORDER REPLACEMENT PARTS

Please send the following information to your local representative; If further assistance is needed, contact the manufacturer's customer service department.

- Model number
- Serial Number (if any)
- Part description and Number as shown in the Replacement Parts Catalog.

LIMITED WARRANTY

HORIZONTAL STEAM & HOT WATER UNIT HEATERS

The Manufacturer warrants to the original owner at the original installation site that the Horizontal Steam and Hot Water Unit Heaters (the "Product") will be free from defects in material and workmanship for a period not to exceed one (1) year from startup or eighteen (18) months from date of shipment from the factory, whichever occurs first. If upon examination by the Manufacturer the Product is shown to have a defect in material or workmanship during the warranty period, the Manufacturer will repair or replace, at its option, that part of the Product which is shown to be defective.

This limited warranty does not apply:

- (a) if the Product has been subjected to misuse or neglect, has been accidentally or intentionally damaged, has not been installed, maintained or operated in accordance with the furnished written instructions, or has been altered or modified in any way.
- (b) to any expenses, including labor or material, incurred during removal or reinstallation of the defective Product or parts thereof.
- (c) to any workmanship of the installer of the Product.

This limited warranty is conditional upon:

- (a) shipment, to the Manufacturer, of that part of the Product thought to be defective. Goods can only be returned with prior written approval from the Manufacturer. All returns must be freight prepaid.
- (b) determination, in the reasonable opinion of the Manufacturer, that there exists a defect in material or workmanship.

Repair or replacement of any part under this Limited Warranty shall not extend the duration of the warranty with respect to such repaired or replaced part beyond the stated warranty period.

THIS LIMITED WARRANTY IS IN LIEU OF ALL OTHER WARRANTIES, EITHER EXPRESS OR IMPLIED, AND ALL SUCH OTHER WARRANTIES, INCLUDING WITHOUT LIMITATION IMPLIED WARRANTIES OF MERCHANTABILITY OR FITNESS FOR A PARTICULAR PURPOSE, ARE HEREBY DISCLAIMED AND EXCLUDED FROM THIS LIMITED WARRANTY. IN NO EVENT SHALL THE MANUFACTURER BE LIABLE IN ANY WAY FOR ANY CONSEQUENTIAL, SPECIAL, OR INCIDENTAL DAMAGES OF ANY NATURE WHATSOEVER, OR FOR ANY AMOUNTS IN EXCESS OF THE SELLING PRICE OF THE PRODUCT OR ANY PARTS THEREOF FOUND TO BE DEFECTIVE. THIS LIMITED WARRANTY GIVES THE ORIGINAL OWNER OF THE PRODUCT SPECIFIC LEGAL RIGHTS. YOU MAY ALSO HAVE OTHER RIGHTS WHICH MAY VARY BY EACH JURISDICTION.

In the interest of product improvement, we reserve the right to make changes without notice.

EQUIPMENT START-UP

Customer _____ Job Name & Number _____

PRE-INSPECTION INFORMATION With power and water/steam off.

Type of Equipment: _____ Unit Heater

Serial Number _____ Model Number _____

Name Plate Voltage: _____ Name Plate Amperage: _____

Steam Hot Water Rating: _____ BTU @ _____ °F
_____ kw @ _____ °C

- Are all panels in place?
- Has the unit suffered any external damage? Damage _____
- Does the piping and electric wiring appear to be installed in a professional manner?
- Has the piping and electric been inspected by the local authority having jurisdiction?
- Is the supply properly sized for the equipment?
- Were the installation instructions followed when the equipment was installed?
- Have all field installed controls been installed?
- Do you understand all the controls on this equipment? **If not, contact your wholesaler or rep. (DO NOT START this equipment unless you fully understand the controls.)**