

Aero Tec™ Installation Guide

Aero Tec™ Models 700 & 750 (115 vac)

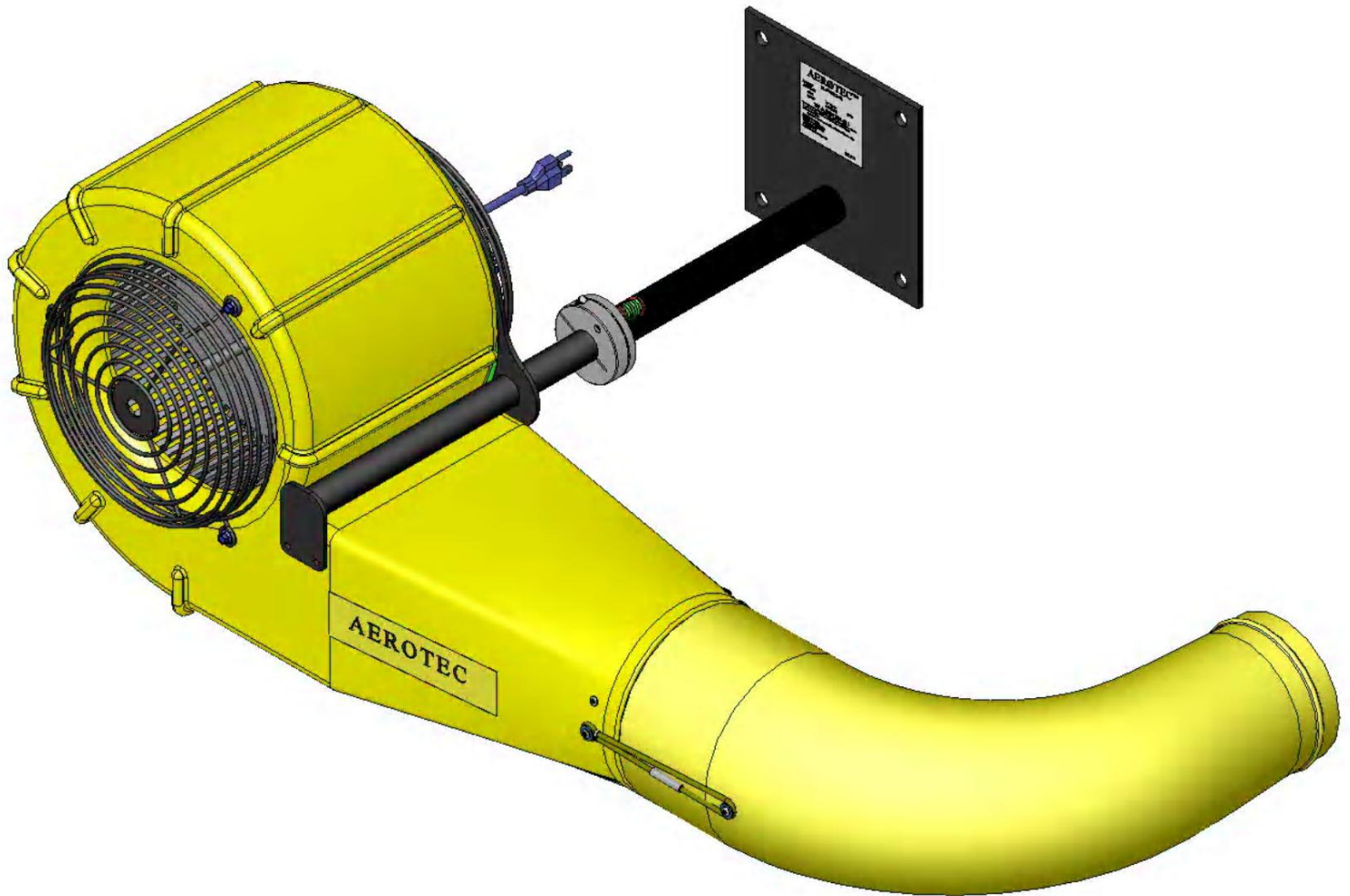

A Product of



340 Gateway Park Drive
North Syracuse, NY 13212
Phone: 315-463-7348
Toll Free: 866-235-7468
Fax: 315-463-8559
Email: sales@dlmanufacturing.com
www.dlmanufacturing.com

Table of Contents

Page 1	General Info / Table of Contents /Approved Hardware & Fasteners
Page 2	AeroTec™ Installation and Assembly
Page 3	AeroTec™ Right Side Mounting Chart
Page 4	AeroTec™ Left Side Mounting Chart
Page 5	AeroTec™ Parts List
Page 6	DL Manufacturing Terms/Conditions/Warranty

YEARLY MAINTENANCE

1. Check power cord for any damage.
2. Check mounting bolts for tightness.
3. Verify all finger guards are properly installed and not damaged.
4. Clean unit.

>WARNING!!!

- Do not install or service AEROTEC™ with the power on.
- Do not use in hazardous or corrosive environments.
- Verify that AEROTEC™ is not distributing exhaust fumes from fork- lifts or auxiliary equipment.

Approved Installer-Supplied Hardware & Fasteners

Mounting Options	Fastener Type / Hardware	Quantity	Notes
Poured Concrete Wall	1/2" x 2-3/4" Wedge Anchor	4	Fastenal Part # 52038
Concrete Block	1/2" x 2-3/4" hollow set drop in anchor and 1/2" washer.	4	Fastenal Part # 50399
Wood backed by solid material	1/2" x 3" Anchor and 1/2" washer. (Type of anchor used will depend on type of solid backing. See above methods)	4	
6" Bollard	6" U-Bolt / 1/2" Nylock / 1/2" Flat Washer	2 / 4 / 4	Fastenal Part #'s 42058 / 1137018 / 1133012
Steel	Weld	8" Weld Bead	1/4" Bead, Min 2" per side

AEROTEC™ INSTALLATION & ASSEMBLY

- STEP 1:** Measure the size of the door opening and determine which side of the opening (left or right) the AEROTEC™ will be mounted.
- STEP 2:** Using the charts and diagrams on Pages 3 and 4, determine the proper mounting location and orientation of the wall mount bracket.

NOTE: *The mounting dimensions shown are recommended for Optimal performance. Some dimensions may vary.*

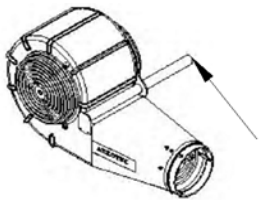

STEP 3: Verify that the shaft collar on the wall bracket is in the proper orientation and mount to the wall using the appropriate hardware listed on Page 1.

STEP 4: Slide the AEROTEC onto the wall bracket (verify that the tube penetrates the wall mount by 3" or more and there is no risk of falling) Install the breakaway elbow with the shock cords. The end of the elbow should be as close to the closed door as possible (2"-3" is optimum).

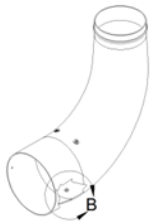

90 Degree Elbow (Breakaway) AT5033

STEP 5: Rotate the AEROTEC™ so the nozzle is directed into the truck body and tighten the set screws. Verify that the outlet of the nozzle is not obstructed by dock seals, shelters or other equipment. **SEE DETAIL A.**

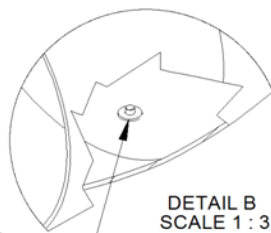

DETAIL B SCALE 1 : 3

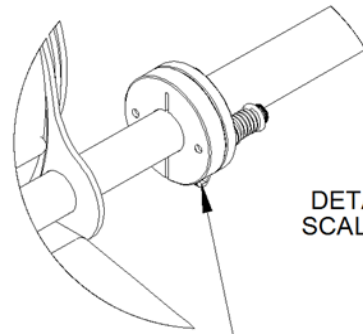

DETAIL A SCALE 1 : 5

Set Screw

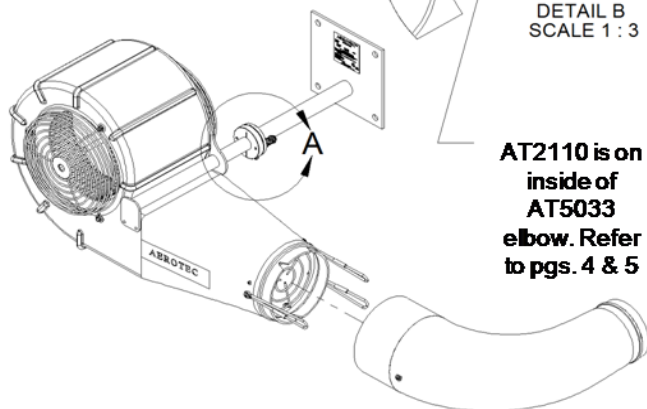

STEP 6: Plug into 115 VAC power outlet. **NOTE:** When AEROTEC™ Model 750 is connected to DL Manufacturing switching equipment, verify the internal circuit breaker is rated for 12 amps.

AEROTEC™ Assembly

Wall Mount Shaft Collar Positioning

Factory Shipped Left Hand Wall Mount
NO ADJUSTMENT REQUIRED

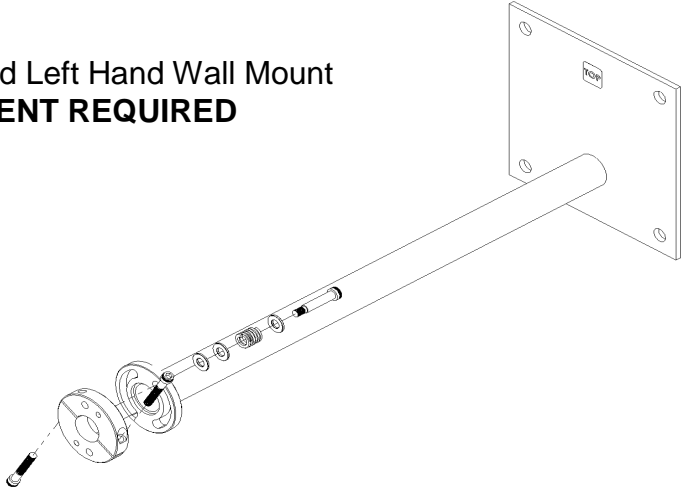

Wall Mount Conversion to Right Hand Mount

- 1) Remove both shoulder Bolts and Springs using 3/16" allen wrench
- 2) Rotate shaft collar counter clockwise to left hand side of web
- 3) Reinstall both shoulder Bolts and springs

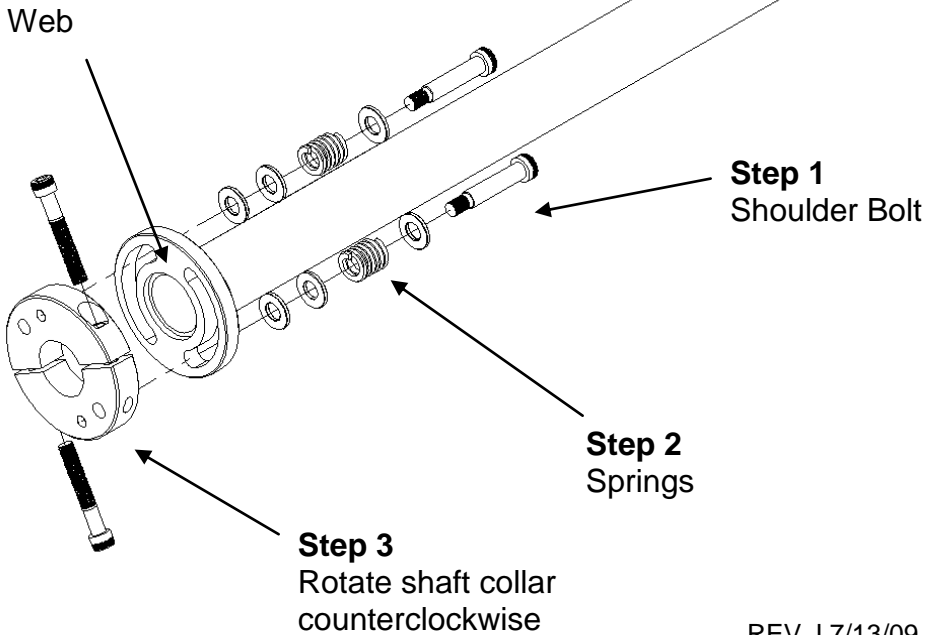
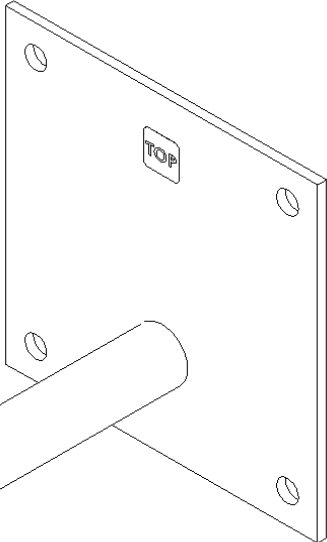

AEROTEC™ LEFT SIDE MOUNTING CHART

LEFT SIDE MOUNTING				
Door Width "A" Dimension	Door Height "B" Dimension	Height From Floor "C" Dimension	Distance From Jamb "D" Dimension	Bracket Position
8'	8'	106"	10"	1ST
8'	9'	118"	10"	1ST
8'	10'	118"	10"	1ST
8' - 6"	9'	112"	10"	1ST
9'	8'	102"	10"	1ST
9'	9'	114"	10"	1ST
9'	10'	114"	10"	1ST
10'	8'	96"	6"	3RD
10'	9'	108"	6"	3RD
10'	10'	108"	6"	3RD

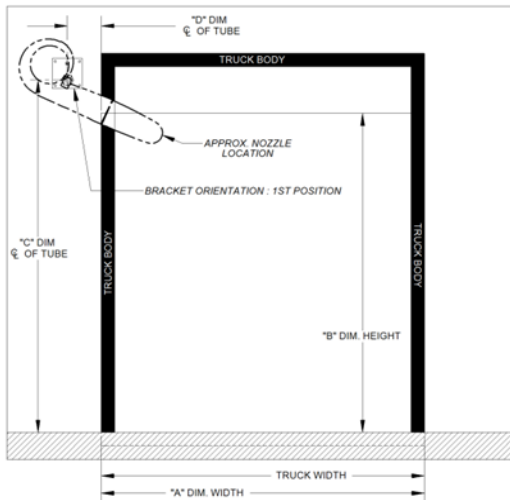

8' x 8' Left Side Mount

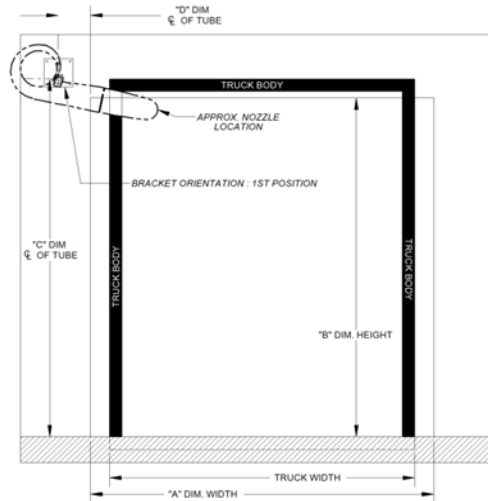

9' x 9' Left Side Mount

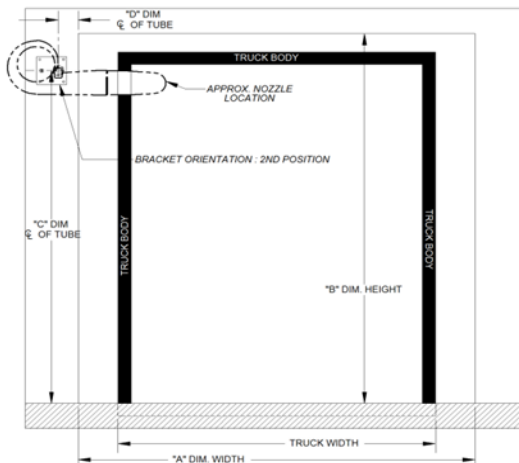

10' x 10' Left Side Mount

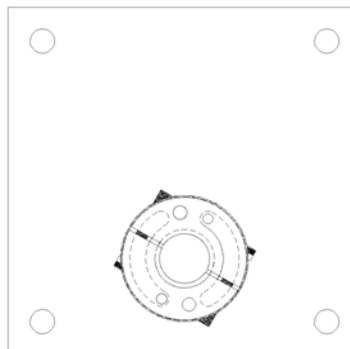

1st Bracket Position
Left Side Mount

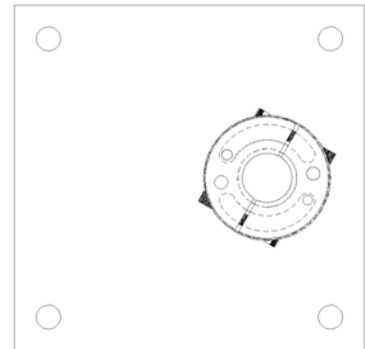

3rd Bracket Position
Left Side Mount

AEROTEC™ RIGHT SIDE MOUNTING CHART

RIGHT SIDE MOUNTING				
Door Width "A" Dimension	Door Height "B" Dimension	Height From Floor "C" Dimension	Distance From Jamb "D" Dimension	Bracket Position
8'	8'	106"	10"	2ND
8'	9'	118"	10"	2ND
8'	10'	118"	10"	2ND
8' - 6"	9'	112"	10"	2ND
9'	8'	102"	10"	2ND
9'	9'	114"	10"	2ND
9'	10'	114"	10"	2ND
10'	8'	96"	6"	4TH
10'	9'	108"	6"	4TH
10'	10'	108"	6"	4TH

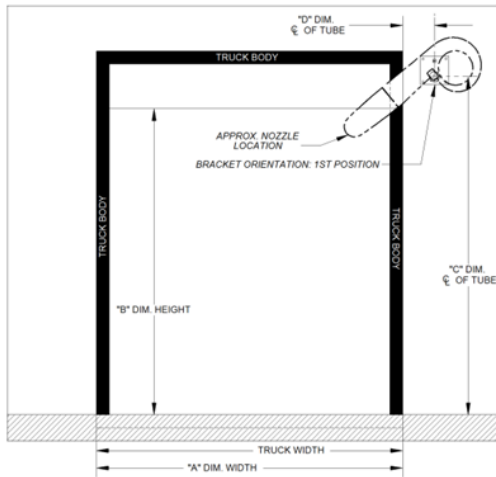

8' x 8' Right Side Mount

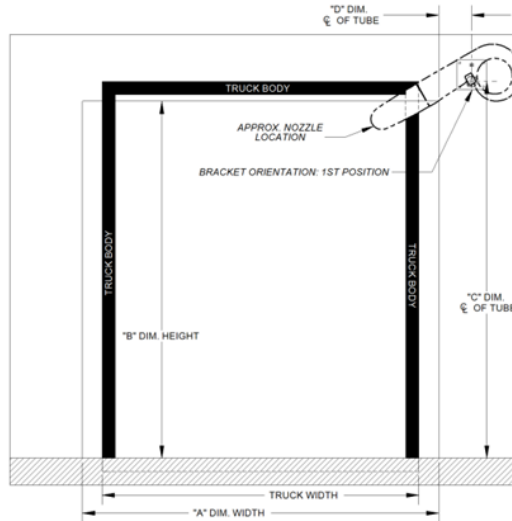

9' x 9' Right Side Mount

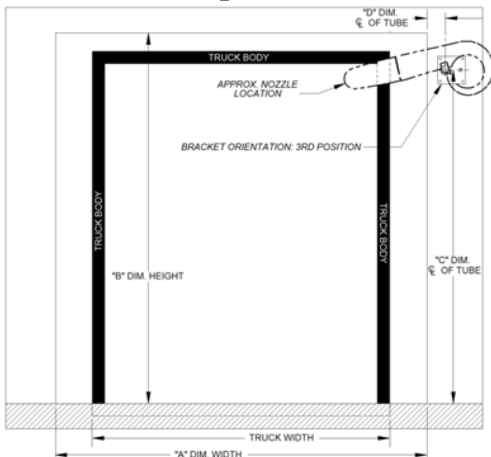

10' x 10' Right Side Mount

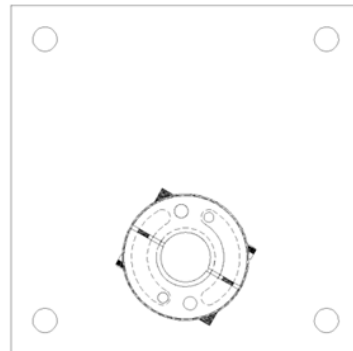

**2nd Bracket Position
Right Side Mount**

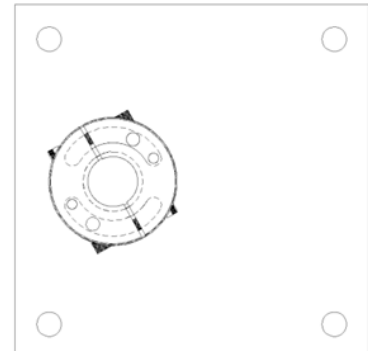

**4th Bracket Position
Right Side Mount**

AEROTECH™ MODEL 700/750 EXPLODED VIEW

PARTS LIST

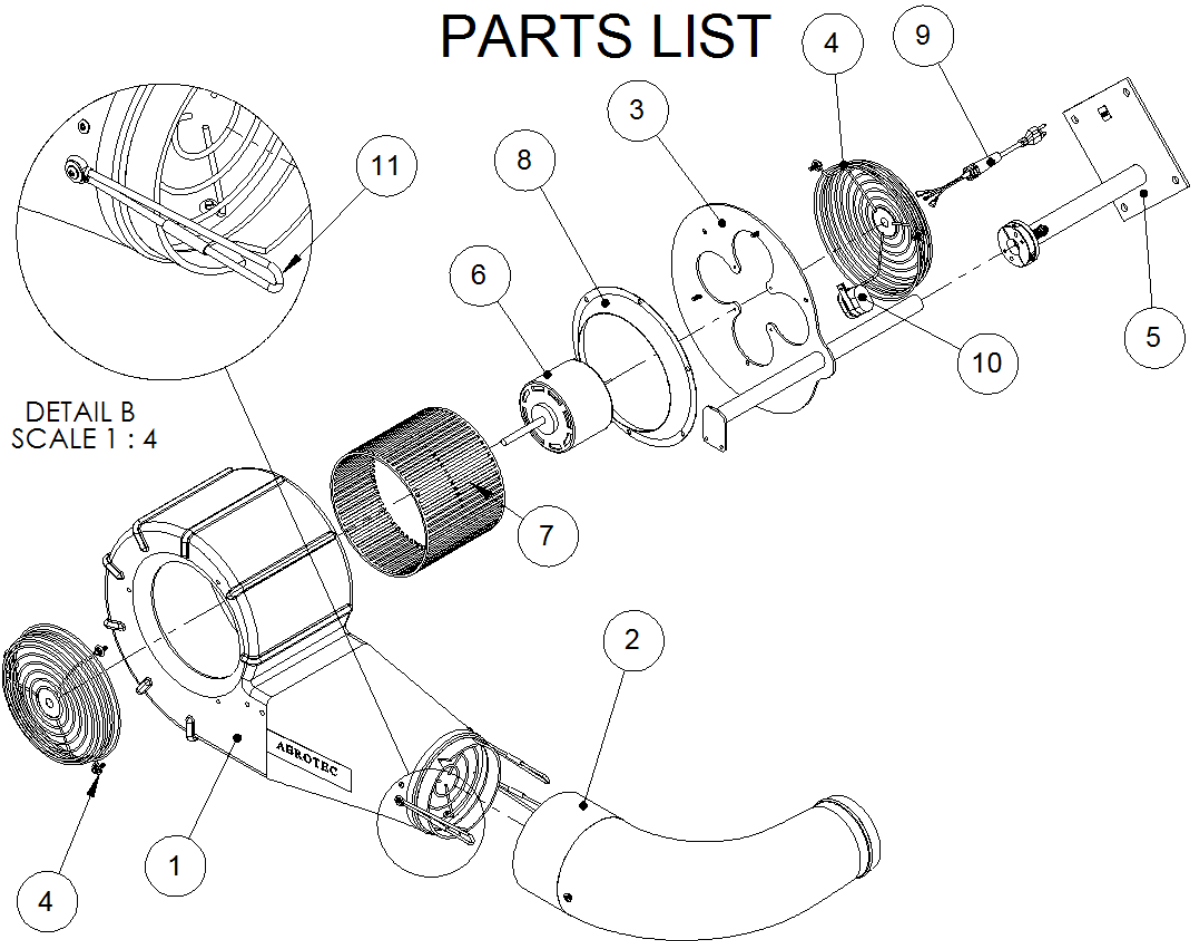

DETAIL B
SCALE 1 : 4

ITEM NO.	MODEL 700 PART NUMBER	MODEL 750 PART NUMBER	DESCRIPTION	QTY.
1	AT5010	AT5020	AEROTECH BLOWER HOUSING	1
2	AT5033	AT5033	REPLACEMENT ELBOW	1
3	AT5011	AT5019	HOUSING BRACKET ASM.	1
4	AT5012	AT5012	FINGER GUARD ASM	2
5	SEE NOTE	SEE NOTE	WALL MOUNT ASM	1
6	AT8010	AT8013	MOTOR	1
7	AT2013	AT2032	BLOWER CAGE	1
8	AT4017	AT4017	AIR INLET RING	1
9	AT8001	AT8001	AEROTECH CORD SET 110VAC	1
10	AT3006	AT3016	CAPACITOR	1
11	AT5022	AT5022	SHOCK CORD ASM	3

NOTE:

AEROTECH'S COME WITH 3 DIFFERENT WALL MOUNTS DETERMINED BY INSTALL LOCATION

AT5013 12in WALL MOUNT ASSEMBLY

AT5040 16in WALL MOUNT ASSEMBLY

AT5016 24in WALL MOUNT ASSEMBLY

DL Manufacturing

Terms / Conditions/ Warranty

Shipping Times

~ Orders for stock items received by 3:00pm EST will be processed for shipment the next day. Orders requesting 2nd Day Air or Overnight Air received by 1:00pm will be processed for same day shipment.

Shipments / Freight

~ All DL Manufacturing orders will ship directly from our facility in North Syracuse, NY.

~ All parts will be shipped via UPS Ground unless you authorize a different service. UPS shipments are prepaid and the charges are added to your invoices.

~ For orders shipping by common carrier, the freight will be FOB, North Syracuse, NY. When "best way" is the preferred shipping method on your order, DL Manufacturing will choose the carrier, unless otherwise stated, for the orders shipping from this facility. No adjustments will be made after the order has shipped.

Returns

~ DL Manufacturing will issue a Returned Material Authorization (RMA) number for any product, parts and accessories. Products should not be returned without an RMA number.

~ Replacement parts will be invoiced at the time of shipping. Invoices will be credited upon receipt and inspection of Returned Material Authorization (RMA).

~ Freight for returns is paid for by the shipper unless otherwise specified by DL Manufacturing.

~ A restocking fee of 25% of net price or a minimum \$20.00 is charged for returns.

~ All replacement parts are warranted for a period of 90 days from shipment.

Cancellation Fees

~ Cancellation charges may be incurred on orders cancelled with DL Manufacturing. Please contact DL Manufacturing to discuss each situation.

Warranty Policy

~ All Products (excluding bulbs) manufactured by DL Manufacturing are warranted to be free from defects for a period of 12 months from the date of shipment, excluding doors, which have a warranty period of 12 months from date of installation or 18 months from shipment, whenever occurs first.

This warranty does not cover unreasonable/improper use or use beyond rated conditions, improper storage, negligence or accident; damage because of incorporated use of equipment with Goods, after Customer has or reasonably should have, knowledge of any defect; or improperly installed by any other Person that is unauthorized by DL Manufacturing.

This warranty is subject to customer covenants to inform all subsequent buyers of the Goods of the limitation on and exclusive of warranties provided for herein. Customer hereby indemnifies and agrees to hold DL Manufacturing harmless from and against all losses, costs and expenses, including reasonable attorney's fees incurred by DL Manufacturing as a result of any third party claim relating to the purchase, sale or use of, or otherwise relating to, the Goods covered by this Agreement.

In no event shall DL Manufacturing be required to repair, replace or reimburse Customer for more than the part or material that is found to be defective and DL Manufacturing's liability shall in such event be no greater than the invoiced price of the item and shall not include labor, shipping or other costs incurred in connection with the reshipment of defective Goods to DL Manufacturing or the reinstallation of such Goods after any repair or replacement. The remedy set forth in this paragraph is expressly agreed to be the sole and exclusive remedy for any breach of warranty. This warranty is exclusive and in lieu of all other warranties expressed or implied, including but not limited to any warranty of merchantability or of fitness for a particular purpose.

Limitation of Liability - In no event as a result of breach of contract, warranty or negligence shall DL Manufacturing be liable for special, or consequential damages including but not limited to loss of profits or revenues, loss of any equipment, cost of capital, cost of substitute equipment, facilities or services, downtime costs or claims of purchasers of the Customer for such damages. Additionally, DL Manufacturing will not be liable for any delay in the performance of contracts and orders, or in the shipment and delivery of goods, or for any damage suffered by the Customer by reason of delay, when such delay is, directly or indirectly, caused by force majeure, including war, Government interference, strikes, embargoes, shortage of labor, fuel, fires, floods, or any other cause or cause whether or not similar in nature to any of those herein before specified beyond DL Manufacturing's control.