



## UNIDOOR PLUS

### SHOWER ENCLOSURE GLASS PANEL INSTALLATION INSTRUCTIONS

#### IMPORTANT

DreamLine™ reserves the right to alter, modify or redesign products at any time without prior notice. For the latest up-to-date technical drawings, manuals or any other details please refer to the [support.BathAuthority.com](http://support.BathAuthority.com) web page.

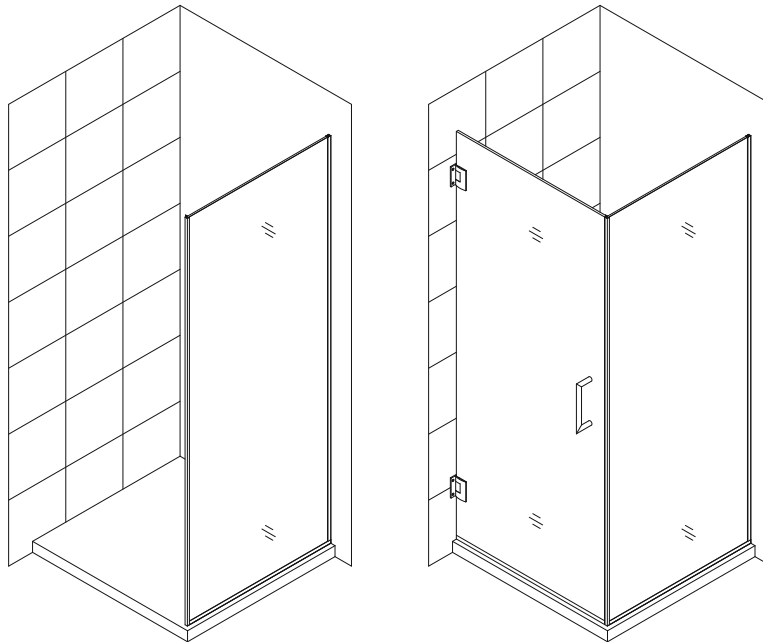

Style L

#### **ATTENTION:**

**This model features the half etched glass option. Please see specific installation instructions on page 12 when applicable.**

Please read these instructions carefully before installing. If you have any questions regarding installation, please call our technical support specialists Monday through Friday 9:00 AM – 5:00 PM EST at Phone: [1-866-731-2244](tel:1-866-731-2244), Fax: [1-866-227-1533](tel:1-866-227-1533) or e-mail our technical support group at [support@BathAuthority.com](mailto:support@BathAuthority.com).

For more information on [DreamLine™ Shower Doors](http://www.BathAuthority.com) and [Enclosure](http://www.BathAuthority.com) please visit [www.BathAuthority.com](http://www.BathAuthority.com)

## Preparation

1. After opening all boxes and packages, read this introduction carefully. Check that all of the needed parts are included in the package by marking all the components on the "Detailed Diagram of Glass Panel Components". Examine boxes and packages for shipping damage. If the unit has been damaged, has a finishing defect, or has missing parts, please contact our customer support department within 5 business days of the delivery date. Please note that **DreamLine™ will not replace any damaged products or missing parts free of charge after 5 business days or if the product has been installed.** Feel free to contact DreamLine™ if you have any questions.
2. **Please note that you should consult your local building codes with questions on installation compliance standards. Building and plumbing codes may vary by location, and DreamLine is not responsible for code compliance standards for your project and will not accept any returns.**
3. If this unit is going to be installed in a new construction, please, install all of the required plumbing and drainage before installing the shower. **Use a competent and licensed (if required by local code) plumber for all plumbing installation.**
4. Prior to the installation, please ensure that the installation surface is level and solid and will be able to support the total weight of the unit. Also make sure that the walls are plumb. Depending on the type of unit you are installing, some adjustments in leveling may be possible. However, irregular installation, surface level or out of square conditions can result in serious problems for your installation. Please note that some adjustments and drilling may be necessary. Please protect all primary surfaces of the product during installation. **Never set your glass down directly onto a tile floor.** Always use a piece of wood or cardboard to protect the bottom edge and corners of the glass.
5. **Note: The installation of this unit requires that you drill down into the threshold.**

## Tools Required

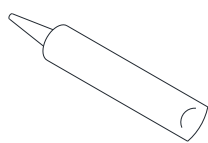

Caulk

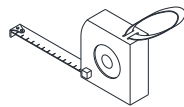

Tape Measure

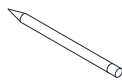

Pencil

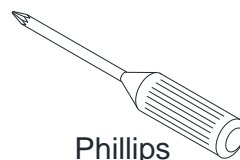

Phillips Screwdriver

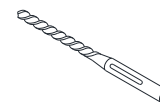

Drill bit (Ø=5/16")



Drill bit (Ø=1/8")



Level



Caulk Gun



Electric Drill



Hammer

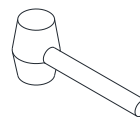

Mallet



Wood

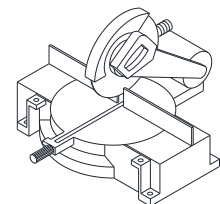

Miter saw

## Detailed Diagram of Glass Panel Components

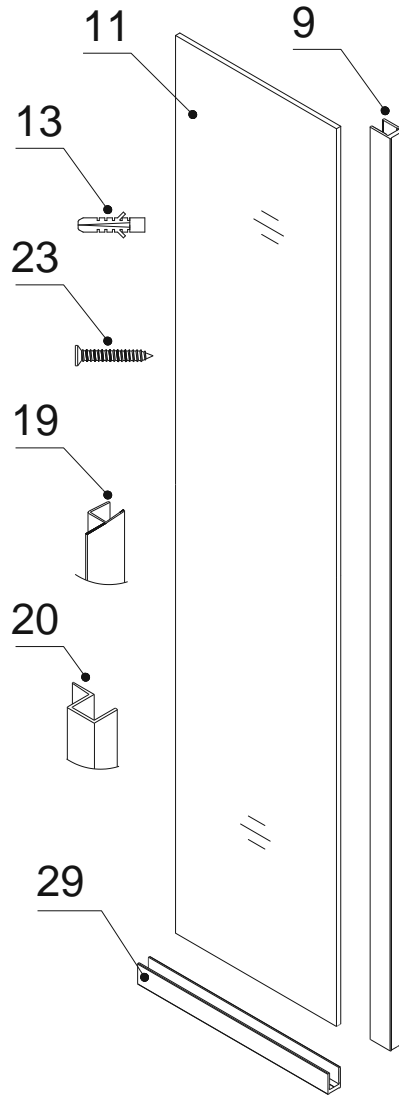

### Packing List

09	U-channel 1 (76", wall profile)	1pc	20	Anti-Water strip (Enclosure)	1pc
11	Stationary glass	1pc	23	Countersunk screw ST4.2x40	14pcs
13	Ø5/16" Wall anchor	14pcs	29	U-channel 2 (40", bottom profile)	1pc
19	Anti-Water strip (door)	1pc*			

**NOTE:** Unpack your unit carefully and inspect it. Lay it out and identify all parts using the detailed diagram and packing list in your manual as a reference. Before discarding the carton, check for small hardware bags that tend to fall to the bottom of the box. If any parts are damaged or missing, please contact DreamLine™ for replacement. The shipping boxes may contain extra parts not used in your model configuration.

\* **ATTENTION:** Anti-Water strip (door) (19) used for in-line panel installation.

## **Style "L": 30"-34" Return Stationary Panel Shower Enclosure Installation**

**NOTE:** The Unidoor shower door needs to be installed prior to proceeding with the following Return Stationary Glass installation instructions. Please see the Single Shower Door installation manual included in the door packaging for complete shower door installation instructions. Before you begin the installation, please recheck your shower opening size. Specific size information can be found in the Size Table below and on our website at [www.BathAuthority.com](http://www.BathAuthority.com).

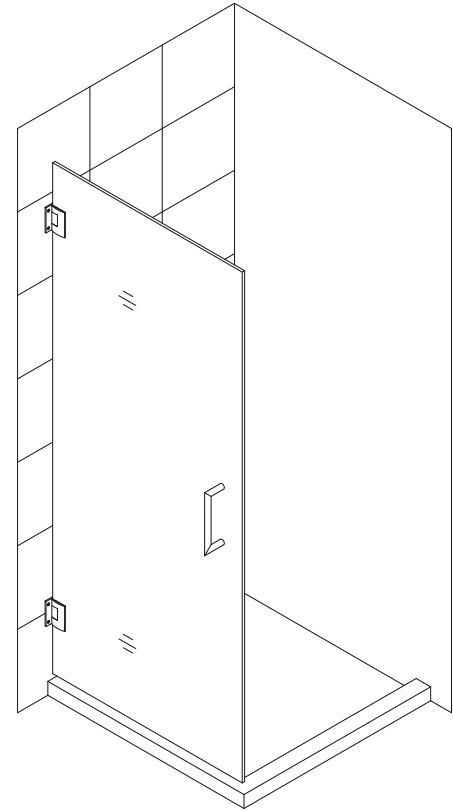

**NOTE:** Use parts from the "Detailed Diagram of Glass Panel Components" for Stationary Glass assembly and installation.

1. Please mark measurement lines on the wall for the Glass door **A** and Return panel **B**.

See Fig. 1 for details.

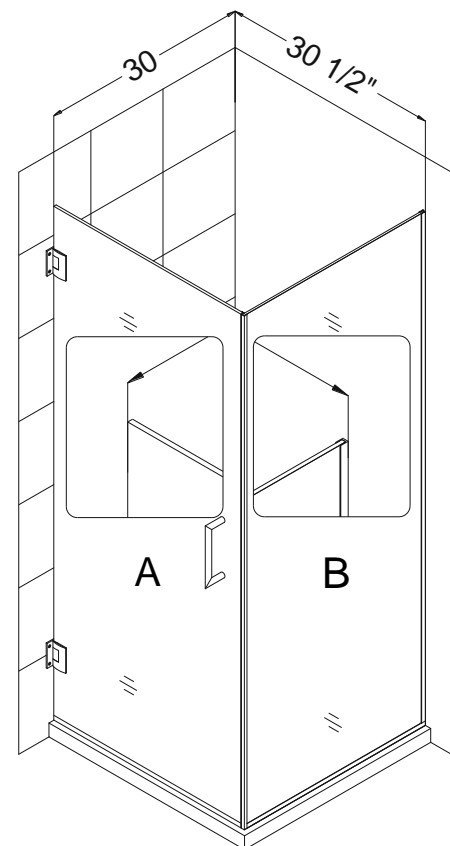

**Fig. 1**

2. Measure the width of your **Stationary glass (11)** panel.

**NOTE:** You will be doing straight cuts for this return stationary panel installation.

**\*It may be necessary to remove any burrs from the cut end of the U-channels with a metal file before placing the U-channel on the glass.**

Use a miter saw to rough cut the **U-channel 2 (40", bottom profile) (29)** to actual width of the glass (+) 1".

See Fig. 2 & 3 for details.

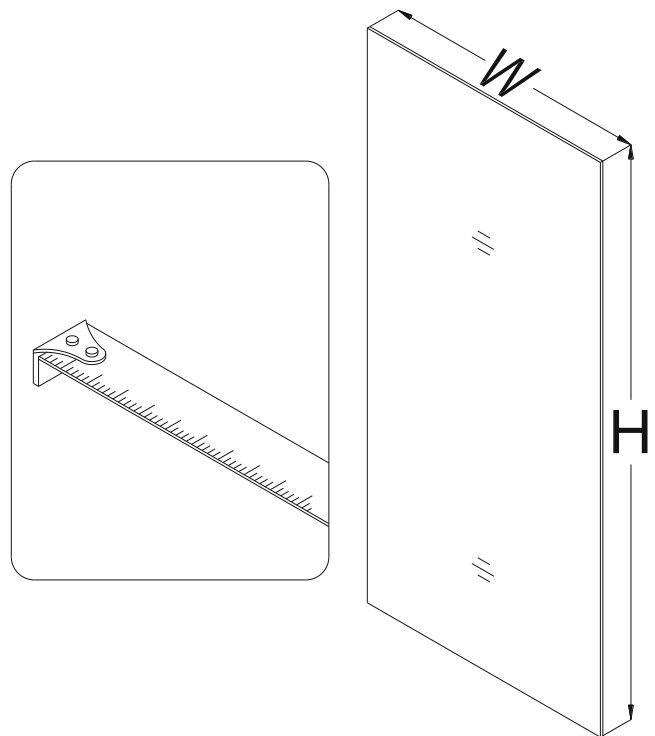

Fig. 2

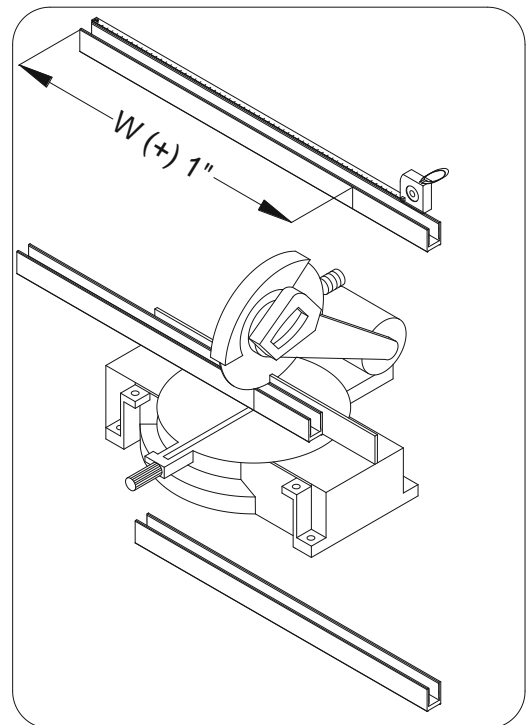

Fig. 3

- Slip the **U-channel 2 (40", bottom profile) (29)** and **U-channel 1 (76", wall profile) (09)** onto the **Stationary glass (11)** in the shown locations.

With the door open place the **Stationary glass** on threshold adjacent to door and in line with wall mark. Adjust the **Stationary glass** and **U-channel 1 (wall profile)** against the wall to compensate for any out of plumb conditions ensuring that the **Stationary glass** is level vertically and **U-channel 1** is flush with the wall.

Mark the **U-channel 2 (bottom profile)** on the door side at the outer vertical glass edge.

Remove the **U-channel 2 (bottom profile)**. Leave the **U-channel 1 (wall profile)** on the **Stationary glass**. Set the **Stationary glass** aside.

Cut the **U-channel 2 (bottom profile)** to the mark (-)  $3/8"$  for **Anti-Water strip (Enclosure) (20)**.

Slip the **U-channel 2 (bottom profile)** back onto the **Stationary glass**.

See Fig. 4 for details.

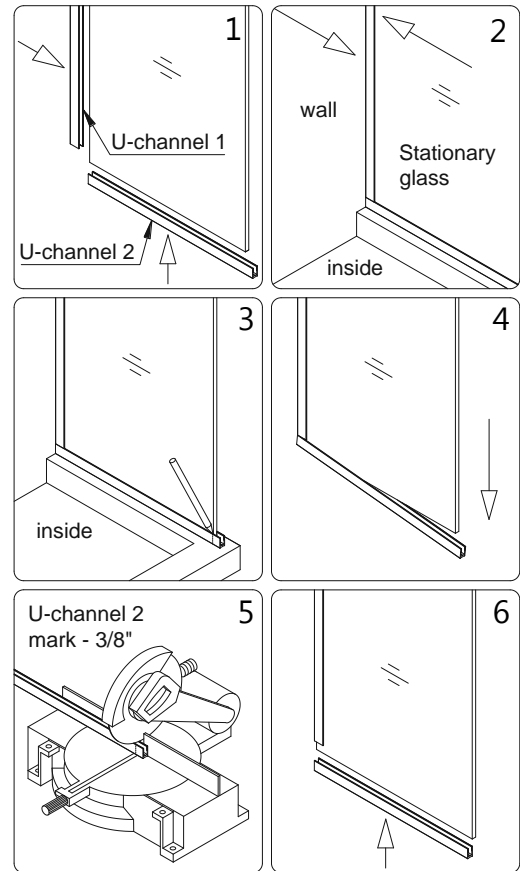

Fig. 4

- Press the **Anti-Water strip (20) (Enclosure)** onto the vertical edge of the **Stationary glass (11)**.

Carefully butt the **Stationary glass** up against the wall vertically according to the outside enclosure mark that was made in step #1. Intermittently use a level throughout these steps to ensure that this glass enclosure is leveled properly.

While securely holding the **Stationary glass**, close the **Glass Door** and align the **Stationary glass** to it.

If needed, adjust the position of the **Stationary glass** to make sure the **Anti-Water strip** makes tight contact to the **Glass Door** from top to bottom. Outline the position of the **Stationary glass** along the inside edge of both **U-channels** on the wall and threshold base.

Mark the **U-channel 1 (wall profile)** at the top horizontal glass edge.

See Fig. 5 for details.

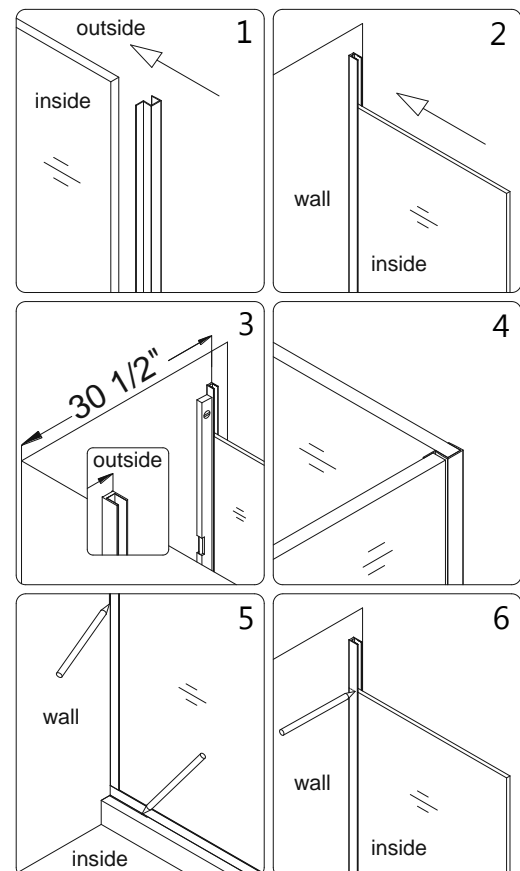

Fig. 5

5. Remove the **U-channel 1 (76", wall profile) (09)**, **U-channel 2 (40", bottom profile) (29)** and **Anti-Water strip (Enclosure) (20)** from the **Stationary glass (11)** and set the **Stationary glass** aside.

Place the **U-Channel 2 (bottom profile)** onto the threshold base in line with the inside threshold mark.

Mark the drill holes on the threshold through the predrilled holes in the **U-Channel 2** and drill the holes using **Ø1/8" drill bit**.

Apply waterproof silicone along the bottom surface and around the holes of the **U-Channel 2** and fasten it to the base with the **Countersunk screws ST4.2×40 (23)**.

**NOTE: The surface needs to be clean and free of debris before applying silicone.**

See Fig. 6 & 7 for details.

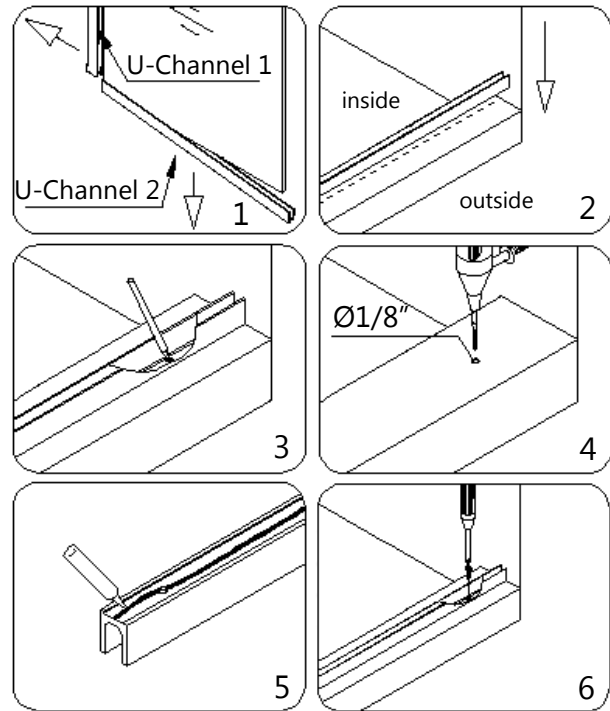

Fig. 6

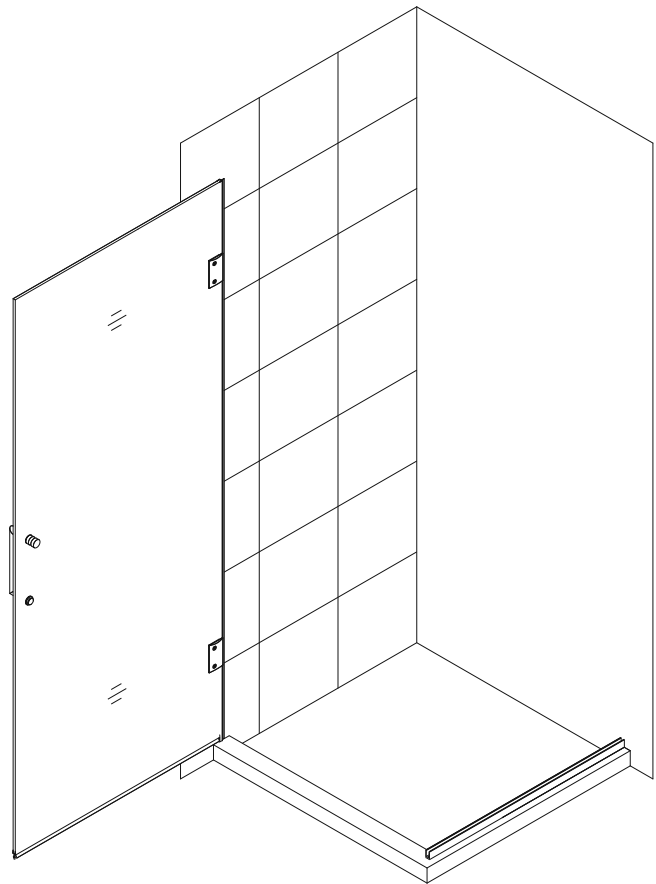

Fig. 7

6. Cut the **U-channel 1 (76", wall profile) (09)** at the top mark that was made in step #4.

Place the **U-Channel 1 (wall profile) (09)** on the **U-Channel 2 (40", bottom profile) (29)** and align vertically with the inside wall mark.

Mark the drill holes on the wall through the predrilled holes in the **U-Channel 1**.

Now drill holes in the wall using **Ø5/16 drill bit** and insert the **Ø5/16" Wall anchors (13)**.

See Fig. 8 for details.

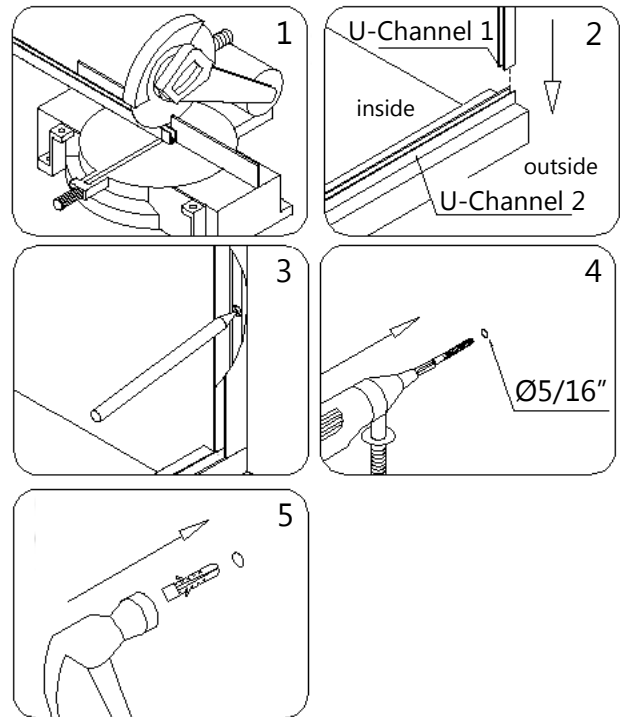

Fig. 8

7. Apply waterproof silicone along the bottom surface and around the holes of the **U-Channel 1 (76", wall profile) (09)**.

Fasten the **U-Channel 1** to the wall with the **Countersunk screw ST4.2x40 (23)**.

Apply Waterproof silicone into the groove of both **U-Channels**.

**NOTE: The surface needs to be clean and free of debris before applying silicone**

See Fig. 9 & 10 for details

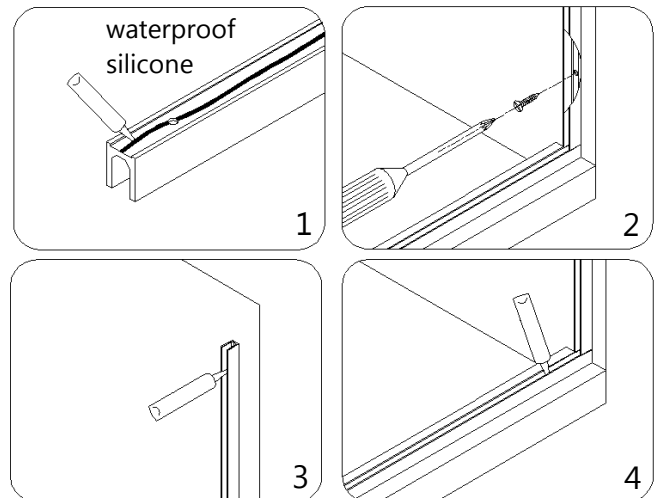

Fig. 9



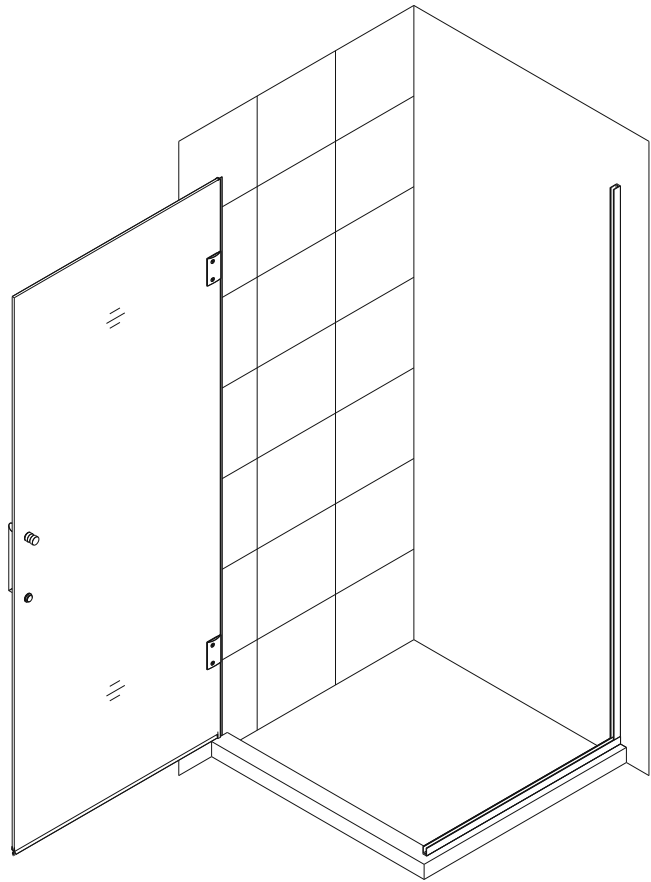

Fig. 10

8. Slide the **Stationary glass (11)** into the groove of both **U-Channels**.

**NOTE:**

If you have difficulty sliding the **Stationary glass** into the **U-Channels**, you can slightly tap on the **Stationary glass** with a rubber mallet and a piece of wood.

See fig. 11 for details.

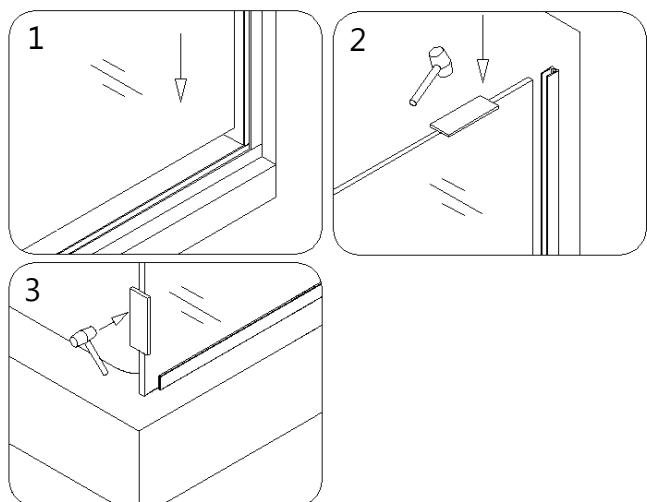

Fig. 11

9. Apply waterproof silicone along the connection of both **U-Channels** to the wall and threshold on the inside of shower.

See Fig. 12 for details.

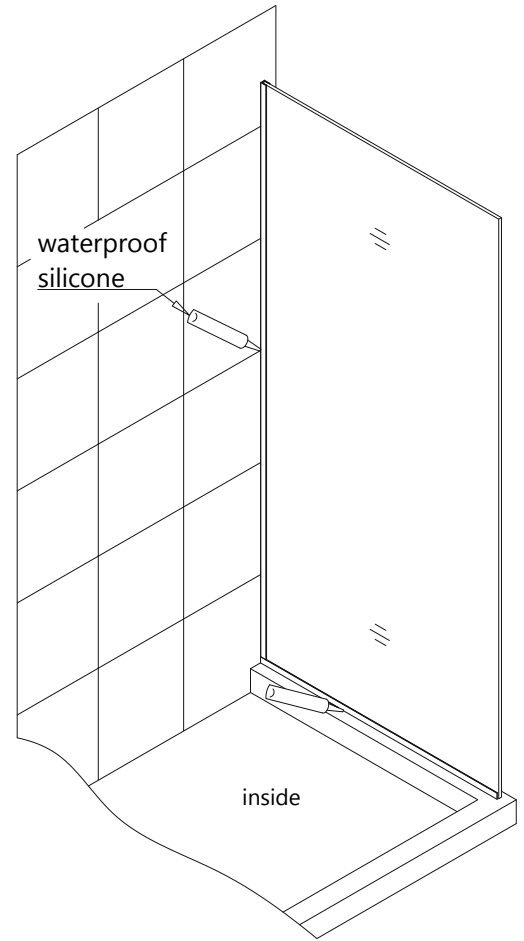

Fig. 12

10. Press the **Anti-water strip (20)** onto the vertical edge of the **Stationary glass (11)**.

See Fig. 13 for details.

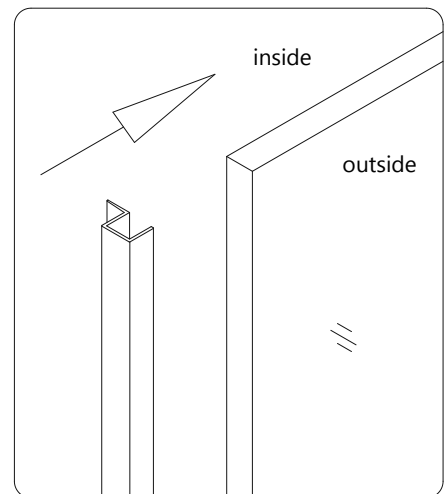

Fig. 13

## **Maintenance**

To ensure long lasting life for your acrylic back walls, wipe them off after each use with a soft cloth. To clean the acrylic back walls use non-abrasive sprays or cream based cleaners. Never use abrasive cleansers, metal brushes or scrapers that could scratch or dull the surface.

To ensure long lasting life for your glass shower products, wipe them off after each use with a soft cloth. Rinse and wipe of the glass using either soft cloth or squeegee to prevent soap buildup. Never use abrasive cleaners and cleaning products that contain scoring agent because this may scratch the surface. Never use bristle brushes or abrasive sponges.

To assure a long lasting finish wipe off the metal parts after each use with a soft cloth. Do not use abrasive cleaners or cleaning products containing ammonia, bleach or acid. If accidentally used, rinse the surface as soon as possible to prevent finish peeling or corrosion. After cleaning the shiny finishes, rinse thoroughly and wipe dry with soft cloth. Clean stainless steel surfaces at least once a week. When applying stainless steel cleaner or polish, work with (not across) the grain. Never use abrasive sponge or cloth, steel wool or wired brushes.

## Style "L":

## Half Etched Glass Installation

**NOTE:** This model features the half etched glass option. Hinged Left installation shown. To install for hinged Right, flip the door to the proper handing.

**-The textured surface of both the return stationary glass and glass door should face out.**

See Fig. 14 for details.

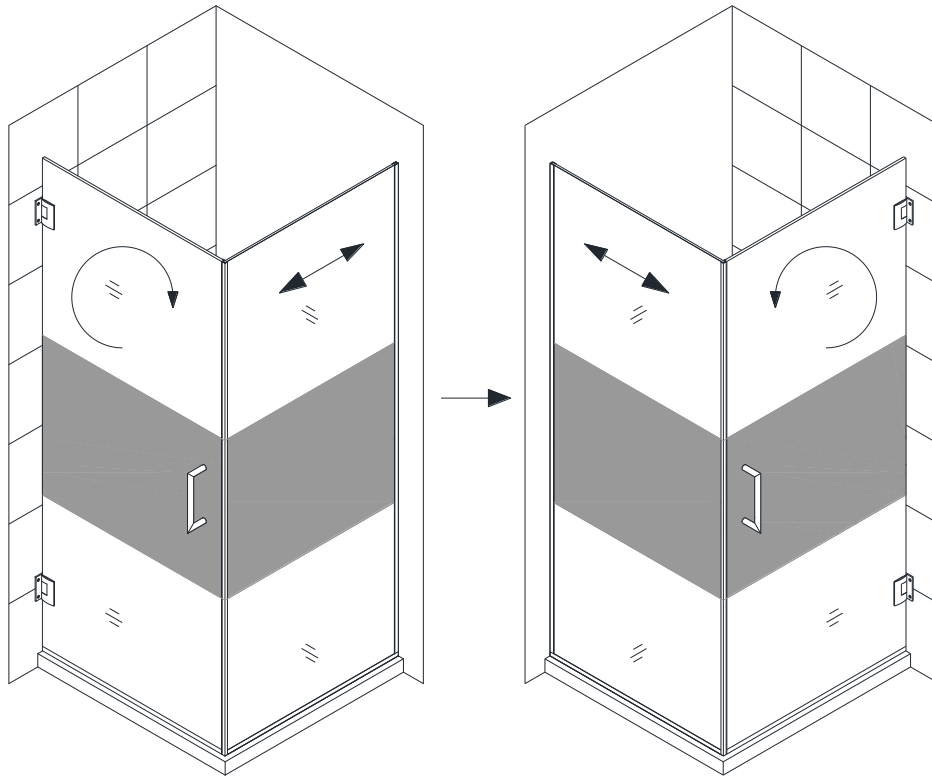

Fig. 14

## DREAMLINE™ EXCLUSIVE LIMITED WARRANTY AS OF MAY 6, 2013

This warranty extends only to the original owner/end-user for household use only and is not transferable to a subsequent owner. This warranty extends for a designated period of time, so long as it remains in use in its original place of installation. This warranty applies only to DreamLine products purchased from an authorized dealer in United States or Canada. Proof of purchase (original sales receipt) from the original consumer purchase must be provided with all warranty claims.

**IN NO EVENT SHALL THE LIABILITY OF DREAMLINE EXCEED THE PURCHASE PRICE OF THE UNIT.**

DreamLine products must be installed by a fully insured and licensed professional. Installation of DreamLine product by anyone other than fully insured licensed professionals shall **VOID THE WARRANTY**. DreamLine recommends that such licensed professionals have experience in the installation of bathroom products. Installation of certain products, including, without limitation, glass products (i.e., shower and tub doors) by an inexperienced installer may result in glass breakage and, consequently, cause personal injury or death.

### PARTS ONLY WARRANTY

This warranty is extensive in that it covers replacement of all defects. LABOR CHARGES AND/OR DAMAGE INCURRED IN INSTALLATION, REPAIR, OR REPLACEMENT, AS WELL AS ANY OTHER KIND OF LOSS OR DAMAGE ARE EXCLUDED

### COMMERCIAL USE AND OTHER EXCLUSIONS

This warranty excludes all industrial, commercial and business usage, whose purchasers are hereby extended a one (1) year limited warranty from the date of purchase for shower and tub doors, a three (3) month limited warranty from the date of purchase for vanities and sinks, with all other terms of this warranty applying except the duration of the warranty.

DREAMLINE JETTED AND STEAM SHOWER CABINS, DREAMLINE SHOWER COLUMNS AND DREAMLINE SHOWER SEATS ARE NOT INTENDED FOR COMMERCIAL USE AND THERE IS NO WARRANTY EXTENDED FOR THESE PRODUCTS FOR COMMERCIAL USE.

DreamLine hereby disclaims all warranties for products sold as dealer or store displays. DreamLine hereby disclaims all warranties for products used outside of the United States or Canada whether expressed or implied, including but not limited to the implied warranties of merchantability and fitness for a particular purpose.

### WARRANTY TERMS

DreamLine will, at its election, repair or replace the product found by DreamLine in its sole judgment, to be defective within the warranty period under normal residential use and maintenance. The replacement of a product is limited to supplying a replacement product or part (same as existing or if not available, comparable product). DreamLine warranty obligation shall be discharged upon tender of parts, replacement or repair of the product. Purchaser's refusal to accept the tender terminates all warranty obligations and **VOIDS THE WARRANTY**. Cost of freight for returning products to DreamLine for repairs or replacement under this limited warranty are the responsibility of the customer. Cost of freight associated with shipping of replacement product or parts to the customer may be charged to customer. Any product replaced or repaired during the warranty period will be covered only for the remaining period of the original warranty. In no event will DreamLine be liable for costs of repair or replacement of any installation material, including but not limited to tiles, marble, etc.

**DREAMLINE IS NOT RESPONSIBLE FOR INSTALLATION, REMOVAL OR REINSTALLATION COSTS OF ANY PRODUCT REQUIRING WARRANTY SERVICES.**

Any modification or alteration of any DreamLine products will void the warranty. DreamLine product installations and repairs must be performed by either a DreamLine authorized agent or a licensed, insured and experienced professional contractor - installation or repairs performed by any other party shall void the warranty. This warranty shall not apply to breakage or damages caused by normal wear and tear, fault, carelessness, abuse, misuse, misapplication, improper maintenance, alteration or modification of the unit, as well as chemical or natural corrosion, accident, fire, flood, act of God or any other casualty. Improper care and cleaning will void the warranty. Use of cleaners containing abrasive cleansers, ammonia, bleach, acids, waxes, alcohol, solvents or other products not recommended for chrome or similar finish, glass or acrylic will void the warranty. For additional product maintenance instructions please refer to product installation manual. DreamLine is not responsible for any issues arising in connection with errors or omissions in information provided on DreamLine's websites. The warranty does not extend to any non-DreamLine plumbing or components installed by installers, end users or by any party other than DreamLine.

**THE FOREGOING WARRANTIES ARE IN LIEU OF ALL OTHER WARRANTIES, EXPRESSED OR IMPLIED, INCLUDING BUT NOT LIMITED TO THE IMPLIED WARRANTIES OF MERCHANTABILITY AND FITNESS FOR A PARTICULAR PURPOSE. BATH AUTHORITY LLC ("DREAMLINE") AND/OR SELLER DISCLAIMS ALL LIABILITY FOR SPECIAL, INCIDENTAL OR CONSEQUENTIAL DAMAGES. DREAMLINE IS NOT LIABLE FOR PERSONAL INJURIES OR DEATH TO ANY PERSON OR FOR ANY DIRECT, SPECIAL, INCIDENTAL OR CONSEQUENTIAL DAMAGE, LOSS OF USE, LOSS OF TIME, LOSS OF PROFITS, INCONVENIENCE, INCIDENTAL EXPENSES, LABOR OR MATERIAL CHARGES, OR ANY OTHER COSTS RESULTING FROM THE USE OF ITS PRODUCTS OR PERTAINING TO THE APPLICATION OF THE PRESENT WARRANTY, OR RESULTING FROM THE REMOVAL OR REPLACEMENT OF ANY PRODUCT OR ELEMENT OR PART COVERED BY THIS WARRANTY.**

### PRODUCT WARRANTY PERIODS

DreamLine is not responsible for product code compliance or for verifying building code restrictions on installation or use and any such compliance is excluded from this warranty. DreamLine reserves the right to modify this warranty at any time - such warranty modifications will not alter the warranty applicable at the time of sale of the products in question. The warranty terms for specific products for consumer (non-industrial, non-commercial, non-business use only) are:

#### SHOWER BACKWALL, SHOWER CABINS (JETTED & STEAM)

DreamLine warrants shower backwalls and shower cabins to be free from defects in workmanship for a period of one (1) year from initial date of purchase by the owner/end-user, contractor or builder from an authorized dealer.

#### SHOWER & TUB DOORS, SHOWER ENCLOSURES

DreamLine warrants shower doors, tub doors and shower enclosures to be free from defects in workmanship and materials under normal residential use for a period of five (5) years from the initial date of purchase by the owner/end-user, contractor or builder from an authorized dealer. Warranty for plastic strips shall be limited to one (1) year. Warranty for any part in Oil Rubbed Bronze finish shall be limited to one (1) year.

#### SHOWER BASES

DreamLine warrants shower bases to be free from defects in workmanship and materials under normal residential use for as long as the original consumer purchaser owns their home in which their product is installed.

#### SHOWER COLUMNS

DreamLine warrants shower columns to be free from defects in workmanship and materials under normal residential use for a period of one (1) year from the initial date of purchase by the owner/end-user, contractor or builder from an authorized dealer.

#### SHOWER SEATS

DreamLine warrants shower seats to be free from defects in workmanship and materials under normal residential use for a period of one (1) year from the initial date of purchase by the owner/end-user, contractor or builder from an authorized dealer. Warranty shall be VOID if the shower seat is not professionally installed on a properly reinforced wall.

#### VANITIES AND VESSEL SINKS

DreamLine warrants bathroom vanities and vessel sinks to be free from defects in workmanship and materials under normal residential use for a period of one (1) year from the initial date of purchase by the owner/end-user, contractor or builder from an authorized dealer.

#### STATE LAWS AND THIS WARRANTY

Some states/provinces do not allow limitations on how long an implied warranty lasts, or the exclusion or limitation of special, incidental or consequential damages, so these limitations and exclusions may not apply to you. This warranty gives you specific legal rights. You may also have other rights, which vary from state/province to state/province.

### WARRANTY SERVICE

The following information will be required for you to file a Warranty claim:

1. Your name, address and telephone number
2. Product model number
3. Brief description of problem (please note that additional information such as photos may be required to fully process your warranty claim)
4. Proof of purchase

You may submit this information by e-mail, mail or fax to:

DreamLine  
Warranty Service Center  
75 Hawk Road  
Warminster, PA 18974  
F:1 - 866 - 857 - 3638  
T:1 - 866 - 731 - 2244  
[Warranty@bathauthority.com](mailto:Warranty@bathauthority.com)



---

TEL: [866-731-2244](tel:866-731-2244)

FAX: [866-227-1533](tel:866-227-1533)

[WWW.BATHAUTHORITY.COM](http://WWW.BATHAUTHORITY.COM)

For more information on [DreamLine™ Shower Doors](#) and [Enclosure](#) please visit [www.BathAuthority.com](http://www.BathAuthority.com)