



CP961



56" x 21.5" x 21.75" (H x W x D)

Two-door cycle defrost refrigerator-freezer in slim width; replaces CP96

Highlights:

Unique 21 1/2" width is ideal for small kitchen spaces

Adjustable shelves and large crisper drawer for optimum storage

Multiple door racks accommodate condiments and bottles

Reversible door swing lets you accommodate any arrangement

Product Features:

| | |
|-----------------------------|---|
| Thin-line design | Limited space is no problem for our thin-line models, designed specifically for those hard-to-fit spots |
| Cycle defrost | Combines an automatic defrosting refrigerator with a manual defrost freezer for a quality performance with energy savings |
| Door storage | 4 full racks offer convenient storage for condiments and bottles |
| Adjustable shelves | Rearrange your refrigerator space to accommodate all shapes and sizes or remove shelves for a simple clean-up |
| Fruit and vegetable crisper | Get the longest life and best taste out of produce by storing greens in a convenient slide drawer |
| Reversible doors | User-reversible door swing for added flexibility |
| Interior light | Automatically illuminates when you open the door |
| Removable freezer shelf | Wire shelf provided for flexible storage |
| Sealed back | Space-saving design that offers easier cleanability |



CP961 Specifications:

| Overview | |
|----------------------------------|----------------|
| Height | 56.0" |
| Width | 21.5" |
| Depth | 21.75" |
| Depth with door at 90° | 41.5" |
| Capacity | 6.4 cu.ft. |
| Defrost Type | Cycle |
| Door | White |
| Cabinet | White |
| US Electrical Safety | ETL |
| Canadian Electrical Safety | ETL-C |
| Energy Usage/Year | 263.0kWh/year |
| Amps | 0.54 |
| Voltage/Frequency | 115 V AC/60 Hz |
| Weight | 97.0 lbs. |
| Shipping Weight | 110.0 lbs. |
| Parts & Labor Warranty | 1 Year |
| Compressor Warranty | 5 Years |
| Refrigerator-Freezer | |
| Door Swing | RHD |
| Reversible | Yes |
| Crisper Qty | 1 |
| Crisper Finish | Transparent |
| Crisper Cover | Glass |
| Refrigerator - Interior Height | 35.25" |
| Refrigerator - Interior Width | 16.5" |
| Refrigerator - Interior Depth | 17.0" |
| Refrigerator - Shelf Type | Wire |
| Refrigerator - Shelf Qty | 3 |
| Refrigerator - Full Door Shelves | 4 |
| Freezer - Interior Height | 11.25" |
| Freezer - Interior Width | 14.5" |
| Freezer - Interior Depth | 17.0" |
| Adjustable Shelves | Yes |
| Interior Light | Yes |
| Thermostat Type | Dial |

| | |
|------------------------|-------|
| Freon | R600a |
| Freon Amount | 1.27 |
| High Side PSI | 110.0 |
| Low Side PSI | 70.0 |
| Level Legs | 2 |
| Compressor Step Height | 8.0" |
| Compressor Step Width | 16.5" |
| Compressor Step Depth | 7.0" |

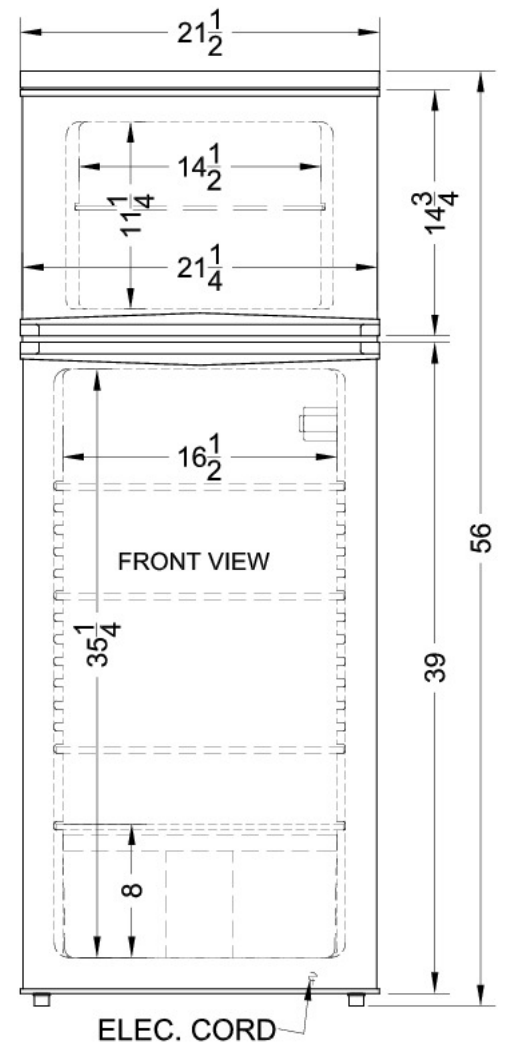
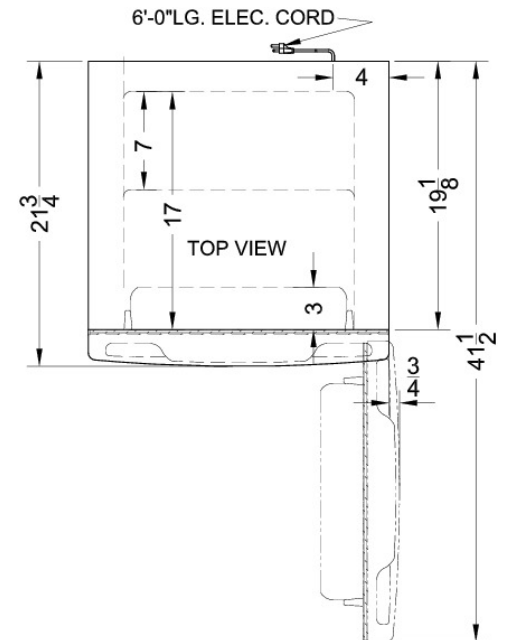

SUMMIT APPLIANCE DIVISION FELIX STORCH, INC.

770 Garrison Avenue, Bronx, NY 10474 USA TEL 718-893-3900 FAX 844-478-8799 info@summitappliance.com www.summitappliance.com