



# BEVERAGE-AIR

3779 Champion Blvd., Winston-Salem, NC 27105  
1-888-845-9800 Fax# 1-336-245-6453  
<http://www.Beverage-Air.com>

## Commercial Refrigeration Equipment General Specification

**3 Year Parts/Labor Warranty**  
**Additional 2 Year Compressor Warranty**

### MARKETMAX™ MERCHANDISER SERIES—GLASS DOOR MERCHANDISER

Single section glass door merchandiser with lighted sign panel used for merchandising and storage of frozen food, frozen novelty items and cold product.

#### CABINET CONSTRUCTION

Heavy duty construction includes white coated steel interior walls. Exterior finish is heavy-duty steel with a baked on durable coating. Choose from black or white finish. S/S exterior and black interior options are available.

Foamed-in-place CFC and HCFC-free polyurethane insulation  
Modern, one-piece grille is easily removed for cleaning and servicing.

Refrigerators have double pane, lowE argon filled glass doors. Freezer models have heated triple pane glass. Inside and outside panes are tempered for added safety. Anti-microbial door handles are standard. Door provides automatic hold-open feature.

Brightly lighted sign panel.

#### SHELVING

Five (5) heavy duty epoxy coated wire shelves per section standard. Four (4) shelf clips included per shelf (field installed). Shelves are adjustable in 1/2" increments.

#### ELECTRONIC CONTROL

Electronic thermostat with manual defrost button provides a digital display of cabinet temperatures, which includes status indicators and key pad for any necessary temperature adjustments.

#### REFRIGERATION

Self-contained bottom mount refrigeration system. Expansion valve refrigerant control on freezer provides quick temperature pull down and reduces compressor run time—meaning reduced energy consumption. Includes automatic condensate disposal. Refrigerators utilize ozone friendly R134a refrigerant. Freezers utilize ozone friendly R404A refrigerant and its defrost system is fully automatic, time-initiated and temperature terminated operation.

Freezer product temperatures from -10°F to -15°F.  
Refrigerator product temperatures from 36°F to 38°F.

#### ELECTRICAL

Interior fluorescent lighting enhances product illumination. Optional LED lighting provides hidden light source for increased product visibility. LED bulbs last up to 10 times longer compared to fluorescent bulbs and renders additional energy savings due to reduced wattage load on compressor.

Item No. \_\_\_\_\_  
Quantity \_\_\_\_\_

### HINGED GLASS DOOR MARKETMAX™ MERCHANDISER SERIES MM23 Refrigerator and Freezers Single Door

MODELS:  
MMR23-1-B  
MMR23-1-W  
MMR23-1-B-LED  
MMR23-1-W-LED  
MMF23-1-B  
MMF23-1-W  
MMF23-1-B-LED  
MMF23-1-W-LED



**MMR23-1-S**  
(SHOWN IN S/S EXTERIOR)  
White and Black Exterior  
finishes available



**MMF23-1-S**  
(SHOWN IN S/S EXTERIOR)  
White and Black Exterior  
finishes available

#### SPECIAL FEATURES

- MMR23 and MMF23 have earned the ENERGY STAR®
- Anti-microbial door handle
- Electronic control with digital display
- Brightly lighted sign panel
- Optional LED lighting
- **Available options:** S/S Exterior, Black Interior, Wine Racks, Spring Feed Dividers, Casters, Audible Alarm With PM Feature, Smart Defrost



115/60/1  
NEMA-5-15P

#### ELECTRICAL CONNECTION

Units pre-wired at factory and include 8' long cord and plug set.

Available From:



\*Note: Not all markings may apply to all model variations.

Model Specified \_\_\_\_\_

Store# \_\_\_\_\_

Location \_\_\_\_\_

Quantity \_\_\_\_\_



**BEVERAGE-AIR**

**MarketMax™ Glass Door Merchandisers**

Model: MMR23, MMF23

| MODEL                                     | MMR23   | MMF23   |
|---|---------|---------|
| <b>EXTERNAL DIMENSIONAL DATA</b>          |         |         |
| Length Overall (inches) - includes handle | 27 1/4" | 27 1/4" |
| Length Overall (mm) - includes handle     | 692     | 692     |
| Depth Overall (inches) - includes handle  | 33 3/4" | 33 3/4" |
| Depth Overall (mm) - includes handle      | 857     | 857     |
| Height Overall— (inches)                  | 78"     | 78"     |
| Height Overall— (mm)                      | 1981    | 1981    |
| Number of doors                           | 1       | 1       |
| Depth with Door Open 90 °                 | 60"     | 60"     |
| <b>INTERNAL DIMENSIONAL DATA</b>          |         |         |
| NET Capacity (cubic ft.)                  | 23      | 23      |
| NET Capacity (Liters)                     | 651     | 651     |
| Internal Length Overall (inches)          | 24"     | 24"     |
| Internal Length Overall (mm)              | 610     | 610     |
| Internal Depth Overall (inches)           | 28 1/2" | 28 1/2" |
| Internal Depth Overall (mm)               | 724     | 724     |
| Internal Height Overall—(inches)          | 61 3/4" | 61 3/4" |
| Internal Height Overall—(mm)              | 1569    | 1569    |
| Number of shelves                         | 5       | 5       |
| <b>ELECTRICAL DATA</b>                    |         |         |
| Full Load Amperes 115/60/1                | 5.8 A   | 10.9 A  |
| <b>REFRIGERATION DATA</b>                 |         |         |
| Horsepower                                | 1/3     | 1/2     |
| <b>WEIGHT DATA</b>                        |         |         |
| Gross Weight (Crated lbs)                 | 300     | 325     |
| Gross Weight (Crated kg)                  | 136     | 147     |

**PLAN VIEWS**

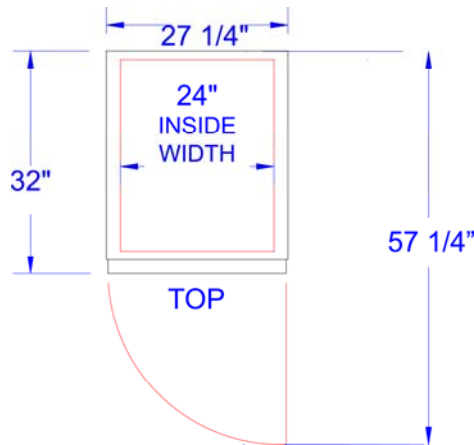
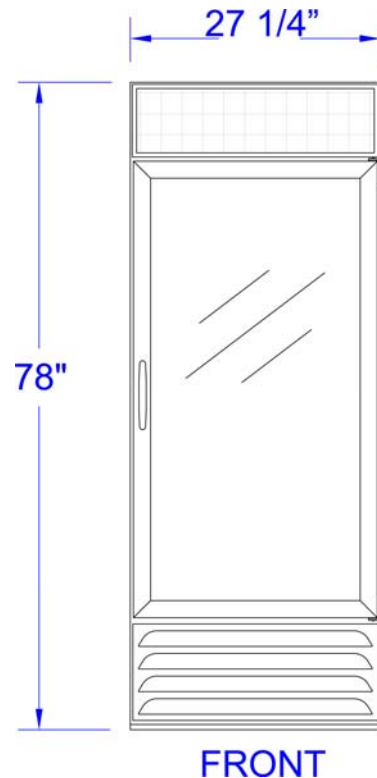
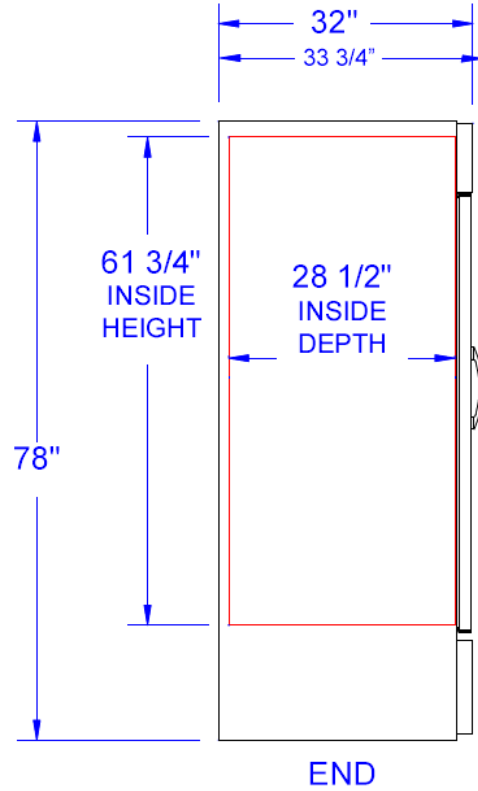

Note: Not all markings may apply to all model variations.

**BEVERAGE-AIR® CORPORATION**

3779 Champion Blvd. • Winston-Salem, NC 27105 USA • (336) 245-6400 • Fax (336) 245-6453 • (888) 845-9800 • www.beverage-air.com

Specifications are subject to change without prior notice. 06/13