

REFRIGERATOR MANUFACTURER
Turbo air
 more durable, efficient, beautiful

4184 E. Conant St.
 Long Beach, CA 90808
 Tel. 310-900-1000
 Fax. 310-900-1077
www.turboairinc.com

Project :	
Model # :	
Item # :	Qty :
Available W/H :	
Approval :	

Undercounter Refrigerator

Undercounters
 M3 Series

3 YEAR PARTS & LABOR WARRANTY

Model : MUR-28



≡ FEATURES & BENEFITS ≡

- **Stainless steel cabinet construction**
 The Turbo Air M3 model boasts a stainless steel exterior (galvanized steel back and bottom). Interior is stainless steel floor with AL sides and back. It guarantees the utmost in cleanliness and long product life. It can add a touch of style to the most refined setting.
- **Field reversible hinge**
- **Efficient refrigeration system**
 M3's solid door refrigerators are designed with oversized and balanced (CFC Free R-134A) refrigeration systems. These include efficient evaporators and condensers for faster cooling and greater efficiency.
- **High-density polyurethane insulation**
 The entire cabinet structure and solid doors are foamed-in-place using high density, CFC free polyurethane insulation.
- **Adjustable, heavy duty, PE (polyethylene) coated wire shelves**
- **Ergonomically designed doors**
 Customers' fatigue fades away with easy grip handles and doors that open effortlessly. These features along with self-closing doors make this the ultimate choice in customer convenience. ABS sheet door liners resist water condensation with thermal efficiency.
- **Magnetic door gaskets**
 Magnetic door gaskets are of one piece construction, removable without tools for ease of cleaning and replacement.
- **Refrigerator holds 33°F ~ 38°F for the best in food preservation**



ENERGY STAR®
 Qualified

Model	Swing Door	CU./FT.	#of Shelves	HP	AMPS	Crated Weight (lbs.)	L x D* x H† (inches)
MUR-28	1	7	1	1/5	3.3	163	27 1/2 x 30 x 30 5/8

Model : MUR-28

ELECTRICAL DATA	
Voltage	115/60/1
Plug Type	Ⓜ NEMA 5-15P
Full Load Amperes	3.3
Compressor HP	1/5
Cord Length (ft.)	9
Refrigerant	R-134A
DIMENSIONAL DATA	
Net Capacity (cu. ft.)	7
Ext. Length Overall (in.)	27 1/2 (699mm)
Ext. Depth Overall (in.)*	30 (762mm)
Ext. Height Overall (in.)†	30 5/8 (777mm)
# of Doors	1
# of Shelves	1
Net Weight (lbs.)	146
Gross Weight (lbs.)	163

Design and specifications subject to change without notice.
Actual shipping weight may differ due to extra packing materials for product protection.
* Depth does not include 1" for rear spacers.
† Height does not include 5" for caster height.

■ **WARRANTY : 3 Year Parts and Labor Warranty**
Additional 2 Year Warranty on Compressor

- **Self-contained system**
- **Standard 4" dia. swivel casters with locks on the front set**

■ **OPTIONAL ACCESSORIES :**

- 2.5" dia. casters available - 1/2" diameter & 13 TPI
- 5" diameter casters
- 6" height ABS plastic legs
- Additional stainless steel shelves
- Additional PE coated wire shelves
- Back splash guard
- Door locks available (extra lead time will apply)
- External digital thermometer available (extra lead time will apply)

PLAN VIEW

(unit : inch)

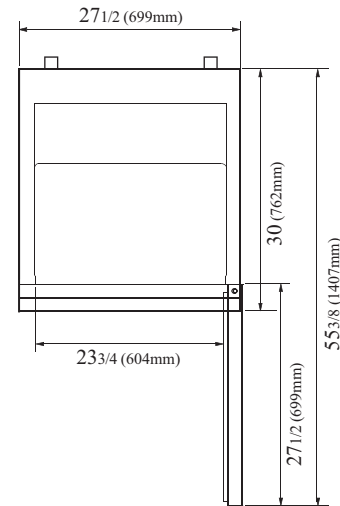

PLAN VIEW

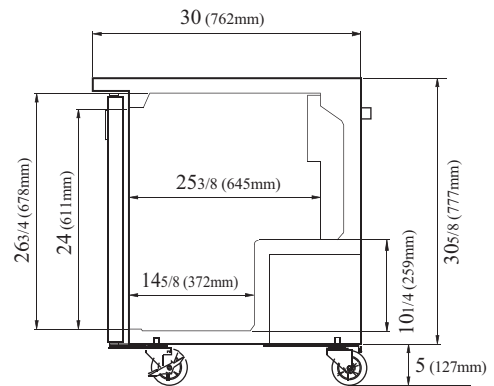

SIDE VIEW

Ver.201509



ENERGY STAR®
Qualified

- Turbo Air : 800-627-0032
- GK : 800-500-3519
- Warranty : 800-381-7770
- AC : 888-900-1002