

REFRIGERATOR MANUFACTURER
Turbo air
 more durable, efficient, beautiful

4184 E. Conant St.
 Long Beach, CA 90808
 Tel. 310-900-1000
 Fax. 310-900-1077
www.turboairinc.com

Project :	
Model # :	
Item # :	Qty :
Available W/H :	
Approval :	

Back Bars

Underbar Equipment
 Back Bars

Model : TBB-2SG/SB



TBB-2SG



TBB-2SB

≡ FEATURES & BENEFITS ≡

- Efficient refrigeration system**
 Turbo Air's refrigerators are designed with oversized and balanced R-134A (CFC Free) refrigeration systems. These include efficient evaporators and condensers for faster cooling and greater efficiency.
- Forced air cooling system**
 Fast cooling and balanced temperature throughout the cabinet.
- Stainless steel countertop and interior**
 The exterior of cabinet is constructed with heavy gauge reinforced stainless steel countertop and wear-resistant black vinyl coated galvanized steel. Interior is stainless steel except galvanized steel top. Turbo Air Back Bar model guarantees utmost in cleanliness and long product life. It also can add a touch of style to the most refined setting.
- LED lighting interior display system**
 Brighter and longer lasting LED lights provide attractive, enhanced illumination compared to fluorescents. It saves energy by producing less heat.
- Triple pane thermal glass (SG Models)**
 Triple pane thermal glass provides extra ability to maintain cool temperatures.
- High-density polyurethane insulation**
 The entire cabinet structure is foamed-in-place using high density, CFC free polyurethane insulation.
- Adjustable, heavy duty, PE (polyethylene) coated wire shelves**
- Ergonomically designed doors**
 Customers' fatigue fades away with easy grip handles and doors that open effortlessly. These features along with self-closing doors make this the ultimate choice in customer convenience.
- Side mount compressor unit**
 By positioning the compressor on the side of the unit, refrigerators can now be serviced without being moved. Our innovative, front breathing feature also allows this model to provide high efficiency in narrow spaces.
- Refrigerator holds 33°F ~ 38°F for the best in beverage preservation**

‡ ENERGY STAR rated models



Model	Swing Door	CU./FT.	1/2 Barrels	#of Shelves	HP	AMPS	Crated Weight (lbs.)	L x D* x H† (inches)
TBB-2SG	2	19	2	6	1/3	7	344	58 3/4 x 27 1/4 x 37 1/8
TBB-2SB‡	2	19	2	6	1/4	7	332	58 3/4 x 27 1/4 x 37 1/8

Model : TBB-2SG/2SB

ELECTRICAL DATA	
Voltage	115/60/1
Plug Type	Ⓢ NEMA 5-15P
Full Load Amperes	7
Compressor HP	1/3(SG) / 1/4(SB)
Refrigerant	R-134A
Cord Length (ft.)	9
Lamp (W)	30
DIMENSIONAL DATA	
1/2 Barrels	2
Cubic Feet	19
Ext. Length Overall in.	58 3/4 (1492mm)
Ext. Depth Overall in.*	27 1/4 (692mm)
Ext. Height Overall in.†	37 1/8 (945mm)
Net Weight lbs	276(SG) / 286(SB)
Gross Weight lbs..	344(SG) / 332(SB)
# of Swing Door	2
# of Shelves	6
Shelf size (LxD) in.	(R)20 x 19 3/8, (L)24 3/8 x 19 3/8

Design and specifications subject to change without notice.
Actual shipping weight may differ due to extra packing materials for product protection.
*Depth does not include 1" for door handle (SG Models).
Depth does not include 2" for rear spacers.
† Height does not include 5" for caster height.

■ **WARRANTY : 3 Year Parts and Labor Warranty
Additional 2 Year Warranty on Compressor**

- **Self-contained system**
- **4" swivel casters standard**
- **2" casters available (optional)**
- **6" adjustable legs available (optional)**
- **Door locks standard (SB model only)**

■ **OPTIONAL ACCESSORIES :**

- 2.5" Diameter casters
- 5" Diameter casters
- 6" ABS plastic legs
- Additional PE coated wire shelves

PLAN VIEW

(unit : inch)

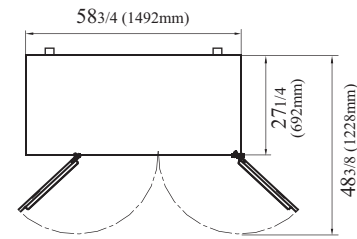
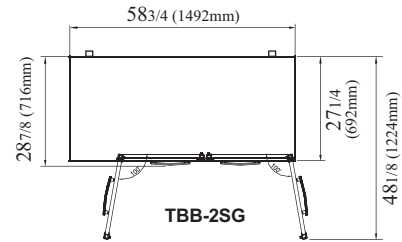

PLAN VIEW

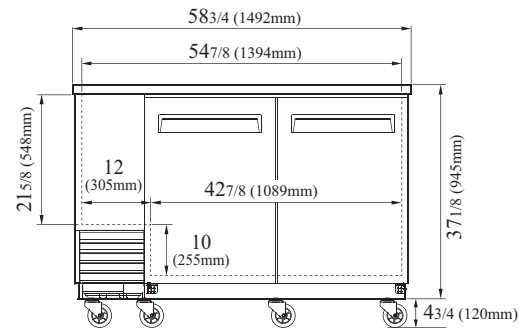

FRONT VIEW

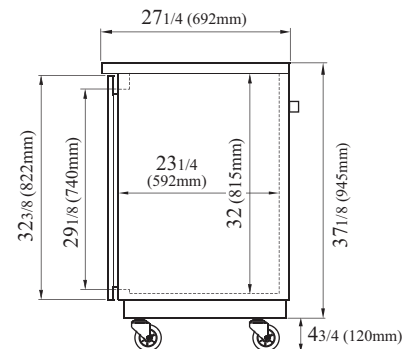

SIDE VIEW

Ver.201504



- Turbo Air : 800-627-0032
- GK : 800-500-3519
- Warranty : 800-381-7770
- AC : 888-900-1002