

**REFRIGERATOR MANUFACTURER**  
**Turbo air**  
 more durable, efficient, beautiful

4184 E. Conant St.  
 Long Beach, CA 90808  
 Tel. 310-900-1000  
 Fax. 310-900-1077  
[www.turboairinc.com](http://www.turboairinc.com)

Project :	
Model # :	
Item # :	Qty :
Available W/H :	
Approval :	

## Swing Door Freezers

Glass Door Merchandisers  
 Freezers

**Model : TGF-49F(B)**

### FEATURES & BENEFITS

- **Digital temperature control system**  
 Provides precise and constant temperature. This level of precision allows food products to remain fresh over an extended period of time.
- **High-tech monitor**  
 The unit will beep if the door has been opened for more than 30 seconds. The monitor digitally displays the present temperature and current status of the freezer. You can easily change the temperature by adjusting the thermostat.
- **LED lighting interior display system**  
 Brighter and longer lasting LED lights provide attractive, enhanced illumination compared to fluorescents. It saves energy by producing less heat, while maximizing the visibility in the display area.
- **LED advertising panel**  
 LED lighting offers 5 times longer lasting life than fluorescents and conserves energy as well.
- **Self-cleaning condenser system**  
 The accumulation of dust in the condenser causes the failure or breakdown of freezers. Especially for freezers, they run normally until they reach a certain level of accumulation. At some point, when they are over the limit, their performance drops quickly resulting in damage to, or disposal of the stored products in freezers. The self-cleaning condenser system keeps the condenser clean and prevents system failure by automatically brushing daily.
- **Efficient refrigeration system**  
 Turbo Air's freezers are designed with oversized and balanced (CFC Free R-404A) refrigeration systems. These include efficient evaporators and condensers for faster freezing and greater efficiency.
- **Triple pane heated glass doors**  
 Equipped with unique triple-pane heated glass doors which enhance energy efficiency by preventing heat transfers and minimizing condensation. Lightweight door construction reduces door maintenance, bushing wear, and facilitates smooth door opening.
- **Automatic evaporator fan motor delays**  
 When the door is opened the evaporator fan will stop, preventing the circulation of hot and moist air from escaping into the refrigerator. This increases energy efficiency and lengthens the life of the compressor.
- **Adjustable, heavy duty, PE (polyethylene) coated wire shelves**
- **High-density polyurethane insulation**  
 The entire cabinet structure is foamed-in-place using high density, CFC free polyurethane insulation.
- **Ergonomically designed doors**  
 Customers' fatigue fades away with easy grip handles and doors that open effortlessly. These features along with self-closing doors make this the ultimate choice in customer convenience.



**TGF-49FB**



**TGF-49F**

**Freezer holds -15°F ~ 5°F for the best in frozen food preservation**



Model	Swing Door	CU./FT.	#of Shelves	HP	AMPS	Crated Weight (lbs.)	L x D x H (inches)
<b>TGF-49F(B)</b>	<b>2</b>	<b>49</b>	<b>8</b>	<b>1 1/4</b>	<b>12.7</b>	<b>587</b>	<b>54 3/8 x 29 3/4 x 78 1/4</b>

## Model : TGF-49F(B)

ELECTRICAL DATA	
Voltage †	115/208~230/60/1
Plug Type †	☺ NEMA L14-20
Full Load Amperes	12.7
Compressor HP	1 1/4
Cord Length (ft.)	7
Refrigerant	R-404A
DIMENSIONAL DATA	
# of Doors	2
Net Capacity (cu. ft.)	49
Ext. Length Overall (in.)	54 3/8 (1382mm)
Ext. Depth Overall (in.)*	29 3/4 (756mm)
Ext. Height Overall (in.)	78 1/4 (1987mm)
Int. Length Overall (in.)	50 1/2 (1283mm)
Int. Depth Overall (in.)	24 1/8 (614mm)
Int. Height Overall (in.)	60 3/8 (1535mm)
Gross Weight (lbs.)	587
Net Weight (lbs.)	554
# of Shelves	8
Shelf Size (L x D) (in.)	21 3/4 x 22 1/2

Design and specifications subject to change without notice.  
Actual shipping weight may differ due to extra packing materials for product protection.  
\* Depth does not include 1-3/8" for glass door handles.  
† TGF-49F requires dual voltage 115/208~230V (NEMA L14-20)

■ **WARRANTY : 2 Year Parts and Labor Warranty  
Additional 3 Year Warranty on Compressor**

- **Magnetic door gaskets**
- **White and black color come standard**

■ **OPTIONAL ACCESSORIES :**

- Additional PE coated wire shelves
- 4" dia. swivel casters available
- Price tag channel shelf available

### PLAN VIEW

(unit : inch)

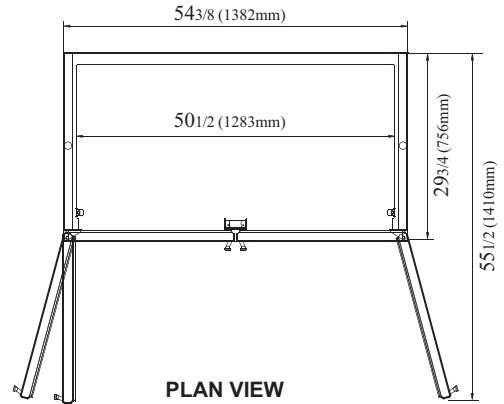

PLAN VIEW

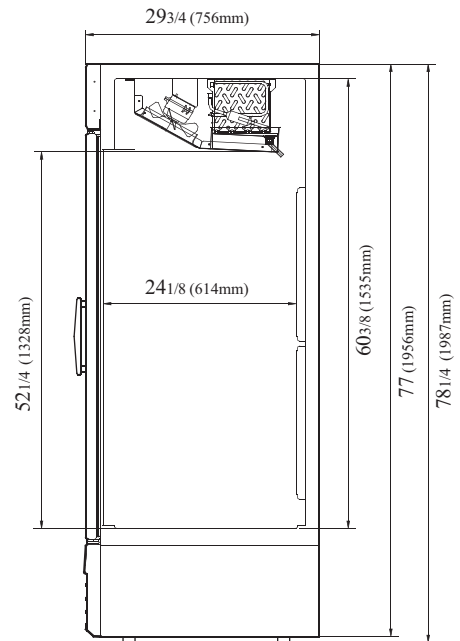

SIDE VIEW

Ver.201510



- Turbo Air : 800-627-0032
- GK : 800-500-3519
- Warranty : 800-381-7770
- AC : 888-900-1002