

**REFRIGERATOR MANUFACTURER**  
**Turbo air**  
 more durable, efficient, beautiful

4184 E. Conant St.  
 Long Beach, CA 90808  
 Tel. 310-900-1000  
 Fax. 310-900-1077  
[www.turboairinc.com](http://www.turboairinc.com)

Project :  
 Model # :  
 Item # : Qty :  
 Available W/H :  
 Approval :

## Swing Door Merchandisers

Glass Door Merchandisers  
 Refrigerators

### FEATURES & BENEFITS

**Model : TGM-72RS**  
**TGM-72RSB**

#### Energy conserving fan control

Utilizing algorithmic air circulation for optimal temperature levels, our innovative fan control system conserves energy by at least 15% and increases compressor life by up to 30%.

#### Hot gas condensate system

Through Turbo Air's creative innovation, the condensate system surfaces have been specially treated to resist corrosion. This not only increases efficiency without the risk of refrigerant leakage from corrosion, but also prevents the overflow of condensate water.

#### LED lighting interior display system

Brighter and longer lasting LED lights provide attractive, enhanced illumination compared to fluorescents. It saves energy by producing less heat, while maximizing the visibility in the display area.

#### LED advertising panel

LED lighting offers 5 times longer lasting life than fluorescents and conserves energy as well.

#### Double pane glass doors with Low-E glass

Energy saving double pane glass doors are equipped with Low-emissivity glass, which reduce outer heat gain and decrease energy consumption. It enhances energy efficiency and minimizes condensation. Lightweight door construction also reduce door maintenance and bushing wear, which in turn facilitates smoother door openings.

#### Efficient refrigeration system

Turbo Air's glass door refrigerators are designed with oversized and balanced (CFC Free R-134A) refrigeration systems. These include efficient evaporators and condensers for faster cooling and greater efficiency.

#### Tasteful and modern appearance

The design of our products is one of our top priorities. Whether you have a restaurant, bar, convenience store or gas station, Turbo Air refrigerators will compliment the appearance of your operation.

#### Magnetic door gaskets

Magnetic door gaskets are of one piece construction, removable without tools for ease of cleaning and replacement.

#### High-density polyurethane insulation

The entire cabinet structure is foamed-in-place using high density, CFC free polyurethane insulation.

#### Adjustable, heavy duty, PE (polyethylene) coated wire shelves

#### Ergonomically designed doors

Customers' fatigue fades away with easy grip handles and doors that open effortlessly. These features along with self-closing doors make this the ultimate choice in customer convenience.

#### Bottom mount compressor units

Turbo Air's bottom mount compressor allows easier access for service and extra storage space above. In addition, the lower area provides a cooler and less greasy operating environment which results in reduced compressor running time.



**Refrigerator holds 33°F ~ 38°F for the best in beverage preservation**



ENERGY STAR®  
 Qualified

Model	Swing Door	CU./FT.	#of Shelves	HP	AMPS	Crated Weight (lbs.)	L x D x H (inches)
<b>TGM-72RS(B)</b>	<b>3</b>	<b>72</b>	<b>12</b>	<b>3/4</b>	<b>12</b>	<b>733</b>	<b>78 x 32 x 79 1/4</b>

## Model : TGM-72RS(B)

ELECTRICAL DATA	
Voltage	115/60/1
Plug Type	Ⓜ NEMA 5-15P
Full Load Amperes	12
Compressor HP	3/4
Cord Length (ft.)	7
Refrigerant	R-134A
DIMENSIONAL DATA	
# of Doors	3
Net Capacity (cu. ft.)	72
Ext. Length Overall (in.)	78 (1981mm)
Ext. Depth Overall (in.)*	32 (813mm)
Ext. Height Overall (in.)	79 1/4 (2013mm)
Int. Length Overall (in.)	74 3/8 (1895mm)
Int. Depth Overall (in.)	23 1/4 (590mm)
Int. Height Overall (in.)	61 5/8 (1539mm)
Net Weight (lbs.)	705
Gross Weight (lbs.)	733
# of Shelves	12
Shelf Size (L x D) (in.)	23 1/2 x 23
Bottle Capacity (Full/Load Line)	840 / 672

Design and specifications subject to change without notice.  
Actual shipping weight may differ due to extra packing materials for product protection.  
\* Depth does not include 1-3/8" for door handle.

■ **WARRANTY : 2 Year Parts and Labor Warranty  
Additional 3 Year Warranty on Compressor**

■ **White and black color come standard**

■ **OPTIONAL ACCESSORIES :**

- 4" dia. casters available
- Price tag channel shelf available

### PLAN VIEW

(unit : inch)

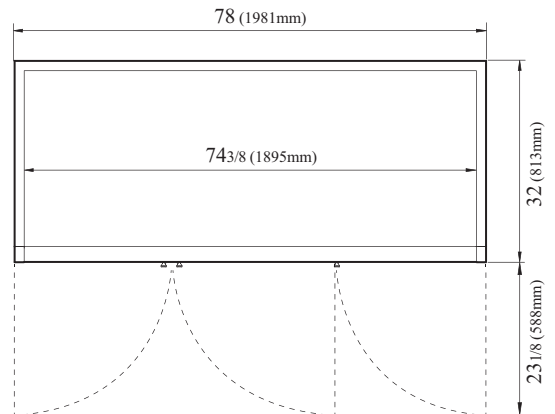

PLAN VIEW

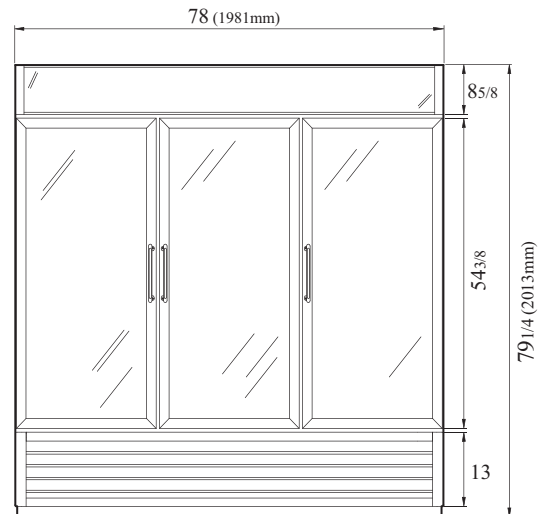

FRONT VIEW

Ver.201510



■ Turbo Air : 800-627-0032 ■ GK : 800-500-3519  
■ Warranty : 800-381-7770 ■ AC : 888-900-1002