

**REFRIGERATOR MANUFACTURER**  
**Turbo air**  
 more durable, efficient, beautiful

4184 E. Conant St.  
 Long Beach, CA 90808  
 Tel. 310-900-1000  
 Fax. 310-900-1077  
[www.turboairinc.com](http://www.turboairinc.com)

Project :	
Model # :	
Item # :	Qty :
Available W/H :	
Approval :	

## Pizza Prep Table

Food Prep Tables - Pizza Prep  
 Super Deluxe Series

**3 YEAR PARTS & LABOR WARRANTY**

**Model : TPR-44SD**



### FEATURES & BENEFITS

- **Cold air curtain system**  
 Our innovative forced air system allows cold air to flow all around the food pan area, covering not only underneath the pan, but also to the front, top and the rear. This unique air flow creates a cold air-shield around the pan, which maintains the food temperature under 41°F (NSF requirement) even when the lids are opened.
- **Stainless steel cabinet construction**  
 The Turbo Air Super Deluxe model boasts a stainless steel interior and exterior (galvanized steel back & bottom). It guarantees the utmost in cleanliness and long product life. The Super Deluxe can add a touch of style to the most refined setting.
- **Sturdy, clean stainless steel shelving**  
 Shelves are the most important part of cleanliness as they come in direct contact with food. After a while, PVC coated wire shelves may peel, rust and lead to unsanitary conditions. Only the Turbo Air Super Deluxe series uniquely provides stainless steel shelving.
- **Extra deep cutting board**  
 Our cutting board is 19-1/4" deep and 1/2" thick to provide ample working space, and is made of easy to use and sanitize LDPE (Low Density Polyethylene). The new side rail cutting board bracket makes it easy to secure and remove the cutting board.
- **Front breathing, side mount compressor unit**  
 By positioning the compressor on the side of the unit, refrigerators can now be serviced without being moved. Our innovative, front breathing feature also allows this model to provide high efficiency in narrow spaces.
- **Insulated pan cover**
- **High-density polyurethane insulation**  
 The entire cabinet structure and solid doors are foamed-in-place using high density, CFC free polyurethane insulation.
- **Efficient refrigeration system**  
 Turbo Air's solid door refrigerators are designed with oversized and balanced (CFC Free R-134A) refrigeration systems. These include efficient evaporators and condensers for faster cooling and greater efficiency.
- **Excellent cooling system**  
 Powerful, forced-air refrigeration system maintains the storage cabinet at a constant temperature. The evaporator fan and a newly designed stainless steel louver allow uniform distribution of cold air to the food pans and throughout the unit to keep food temperature within the NSF standard 7 requirements.
- **Magnetic door gaskets**  
 Magnetic door gaskets are of one piece construction, removable without tools for ease of cleaning and replacement.
- **Refrigerator holds 33°F ~ 41°F for the best in food preservation**



Model	Swing Door	CU./FT.	#of Shelves	#of Pans	HP	AMPS	Crated Weight (lbs.)	L x D* x H† (inches)
TPR-44SD	1	14	2	6	1/4	6.3	302	44 x 32 1/4 x 36

# Pizza Prep Table

Food Prep Tables - Pizza Prep  
Super Deluxe Series

## Model : TPR-44SD

ELECTRICAL DATA	
Voltage	115/60/1
Plug Type	Ⓜ NEMA 5-15P
Full Load Amperes	6.3
Compressor HP	1/4
Cord Length (ft.)	6
Refrigerant	R-134A
DIMENSIONAL DATA	
Ext. Length Overall (in.)	44 (1118mm)
Ext. Depth Overall (in.) *	32 1/4 (819mm)
Ext. Height Overall (in.) †	36 (914mm)
# of Doors	1
# of Shelves	2
# of Pans	6
Net Capacity (cu. ft.)	14
Net Weight (lbs.)	222
Gross Weight (lbs.)	302

Design and specifications subject to change without notice.

Actual shipping weight may differ due to extra packing materials for product protection.

\* Depth does not include 3" for cutting boards and 1" for rear spacers.

† Height does not include 5" for caster height.

### ■ WARRANTY : 3 Year Parts and Labor Warranty Additional 2 Year Warranty on Compressor

- Self-contained system
- Standard 4" dia. swivel casters with locks on the front set
- Standard 1/3 size, 6" deep condiment pans included
- 19-1/4" deep, 1/2" thick cutting board included

### ■ OPTIONAL ACCESSORIES :

- 2.5" dia. casters available - 1/2" diameter & 13 TPI
- 5" diameter casters
- 6" heights ABS plastic legs
- Additional stainless steel shelves
- Stainless steel single over-shelf
- Door locks available (extra lead time will apply)
- External digital thermometer available (extra lead time will apply)

## PLAN VIEW

(unit : inch)

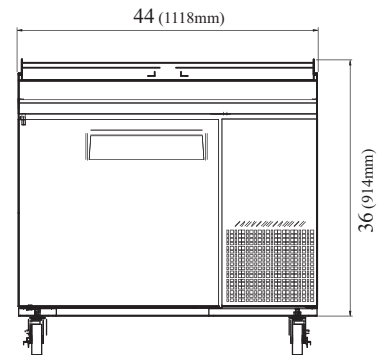

FRONT VIEW

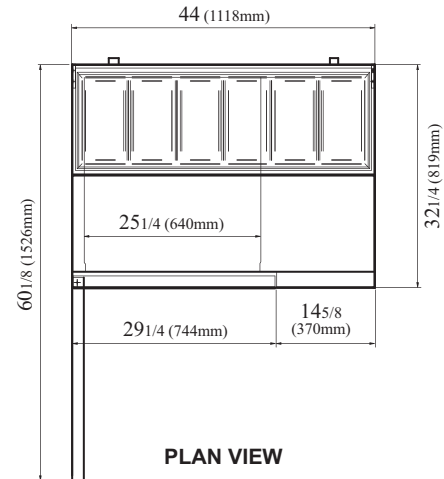

PLAN VIEW

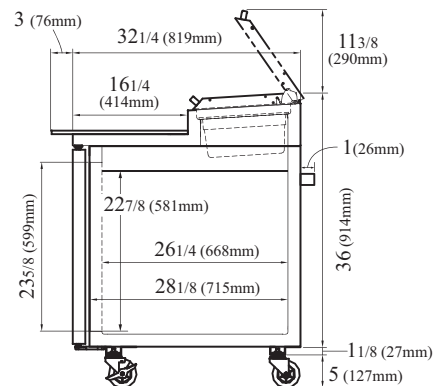

SIDE VIEW

Ver.201509



- Turbo Air : 800-627-0032
- GK : 800-500-3519
- Warranty : 800-381-7770
- AC : 888-900-1002

REFRIGERATOR MANUFACTURER  
**Turbo air**

**GERMAN KNIFE**

**RADIANCE**

**GREEN WORLD**

AIR CONDITIONER MANUFACTURER  
**Turbo air**