

OWNER'S MANUAL

IMPORTANT: READ OWNER'S MANUAL CAREFULLY
Please fill out and return your warranty card

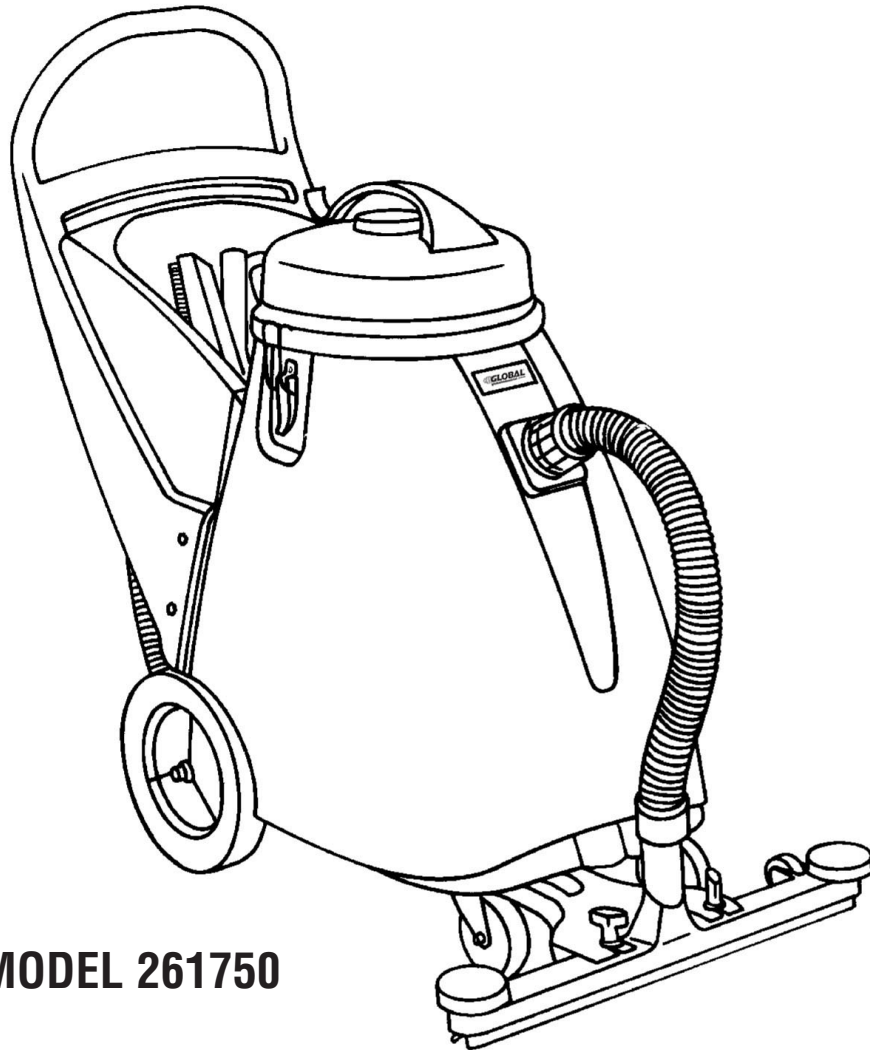

MODEL 261750

TABLE OF CONTENTS



CONGRATULATIONS on your purchase of a Global product. We appreciate your business and will do everything in our power to keep you happy with your purchase for many years to come.

Your purchase entitles you to the best protection by one of the most comprehensive warranties in the industry.

Thank you for purchasing a GLOBAL product.

TABLE OF CONTENTS

SAFETY PRECAUTIONS	3
HANDLE ASSEMBLY	4
MACHINE OPERATION	5
MACHINE MAINTENANCE & STORAGE	6
PARTS LIST	7-12
WIRING DIAGRAM	13

SAFETY PRECAUTIONS

GROUNDING INSTRUCTIONS

This machine must be grounded! Grounding provides the path of least resistance for electrical current. To reduce the risk of electrical shock should the machine malfunction, the machine has a special grounding plug.

! WARNING

Do not remove the ground pin under any circumstances!

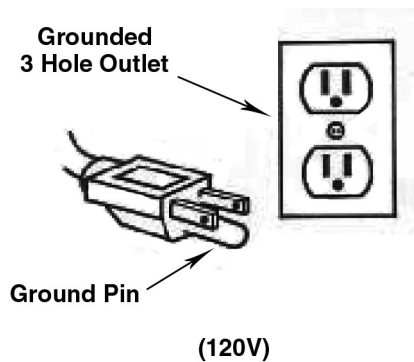

This machine is intended for commercial use. It is constructed for use in an indoor environment and is not intended for any other use.

- Use with approved accessories only
- Use with non-approved accessories voids warranty
- DO NOT modify machine
- Modification to machine voids warranty

All operators shall read, understand and exercise the following safety precautions:

1) Do not operate machine:

- Unless trained and authorized
- Unless you have read and understood operators manual
- In flammable or explosive areas.
- With damaged cord or plug.
- If not in proper operating condition.
- In outdoor areas.
- In standing water.
- Without bag/filters in place
- With the use of extension cords.

2) Before operating machine:

- Make sure all safety devices are in place and operate properly.

3) When using machine:

- Do not run machine over cord.
- Do not pull machine by cord or plug.
- Do not pull cord around sharp edges or corners.
- Turn power switch to "off" prior to unplugging machine.
- Do not unplug by pulling on the cord.
- Do not stretch cord.
- Do not handle plug with wet hands.
- Keep cord away from heated surfaces.
- Do not pick up burning or smoking debris such as cigarettes, matches or hot ashes.
- Report any damages to your supervisor.
- DO NOT attempt to fix machine by yourself. All repairs must be made by authorized technicians.

4) Before leaving or servicing machine:

- Turn off machine.
- Unplug cord from outlet.

5) When servicing machine:

- Unplug cord from outlet.
- Use manufacturer supplied or approved replacement parts.
- Any lifting or hoisting of machine should be done with OSHA approved equipment and safety precautions.

HANDLE ASSEMBLY INSTRUCTIONS

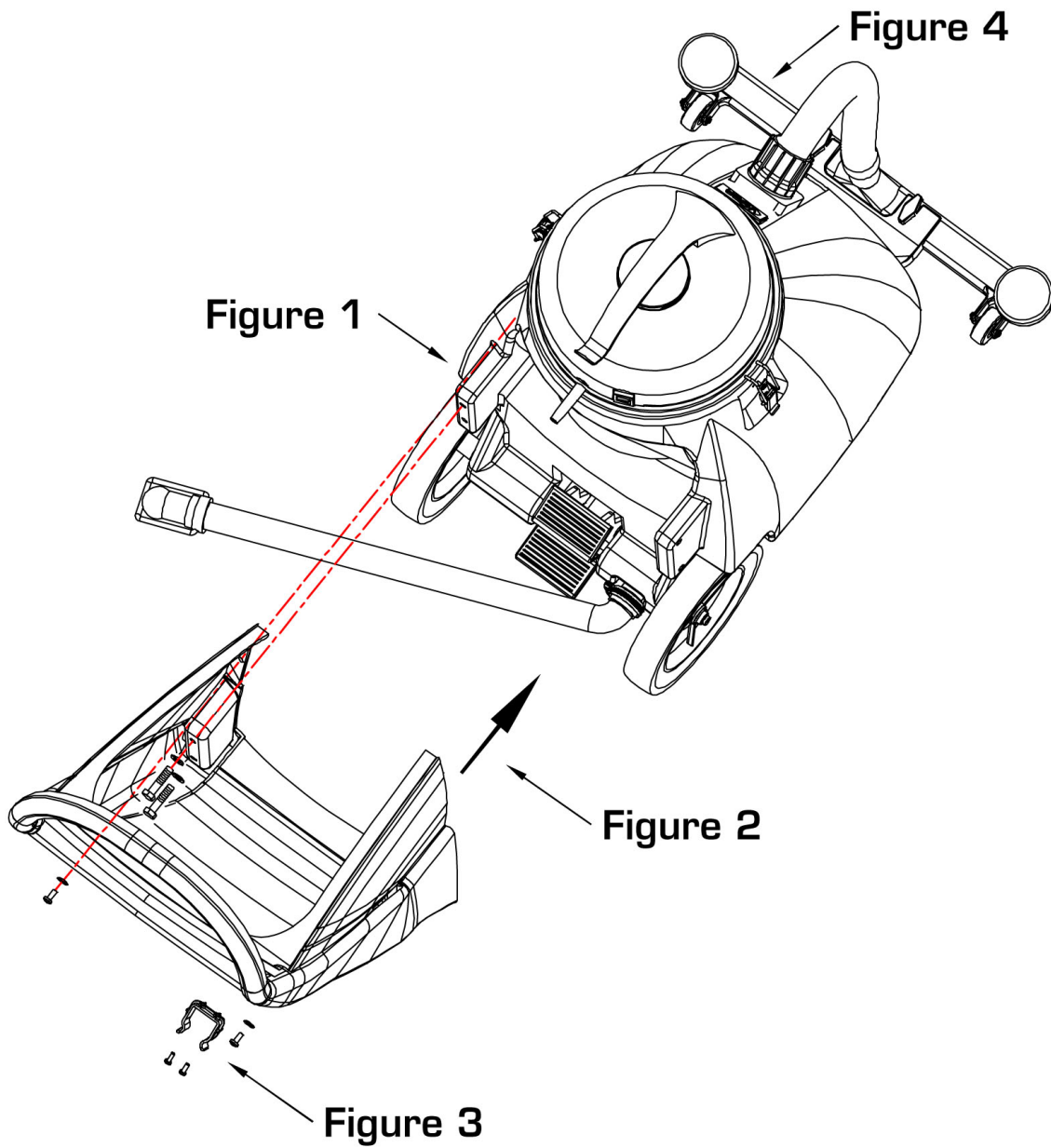

ATTACHING HANDLE

1. Remove handle from ship position and remove upper handle mounting screws from machine (Figure 1).
2. Realign handle, screws & washers as shown (Figure 2).
3. Attach rear hose dump clamp (Figure 3).
4. Attach front mount squeegee (Figure 4).

OPERATION OF WET & DRY VACUUM

READ OPERATOR'S MANUAL THOROUGHLY PRIOR TO OPERATING OR SERVICING THIS MACHINE.

WET PICKUP

1. Remove vacuum head and remove the cloth or paper filter from vacuum, install the bubble buster.
2. While vacuum head is removed, check to make sure that the float shut-off is unobstructed and fully functional.
3. Replace vacuum head and latch it in place.
4. Connect vacuum hose to inlet on the machine body.
5. Attach appropriate accessory tool for the job to be completed.
6. Plug power cord into a grounded outlet.

WARNING

Never use an extension cord in conjunction with the standard power cord.

7. If using the front-mounted squeegee assembly, be sure that squeegee is attached to front of machine.
8. If using the front-mounted squeegee assembly, lower squeegee to the floor by depressing the top half of the pedal (rear of the machine) forward with your foot.
9. Turn power switch to "on" position.
10. During wet pickup, the float shut-off will automatically prevent water from entering the recovery tank once the recovery tank is full.

WARNING

If foam develops in the recovery tank during wet vacuuming, use de-foamer chemical to help eliminate the foam. Foam will not activate the float shut-off, and therefore, may cause vacuum motor damage.

11. To raise the squeegee assembly back to transport position, depress the bottom half of the pedal (rear of the machine) downward with your foot.

WARNING

Be sure that the handle is properly assembled on machine body prior to operating machine.

WARNING

The shovelnose wet –dry vacuum includes the GV25014 "bubble buster" blue nylon foam suppression bag. This bag must be used in all wet pick-up applications. Failure to use the bag will void the warranty on the vacuum motor.

DRY PICKUP

1. Remove vacuum head and bubble buster, and be sure the cloth or paper filter is properly installed.

WARNING

Do not operate machine without bag or filter properly installed.

2. Replace vacuum head and latch it in place.
3. Connect vacuum hose to inlet on the machine body.
4. Attach appropriate accessory tool for the job to be completed.
5. Plug power cord into a grounded outlet.

WARNING

Never use an extension cord in conjunction with the standard power cord.

6. Turn power switch to "on" position.
7. Check the filter bag periodically to see if it is full. For optimal performance, replace bag when it is 3/4 full.

DRAINING THE RECOVERY TANK

1. Unplug machine from power outlet.
2. Transport machine to nearest floor drain or bucket.
3. Remove drain hose from rear of machine. Remove ball plug from drain hose, and drain the contents of the tank.
4. After the contents have drained, remove the vacuum head and rinse recovery tank with clean water.
5. Replace the ball plug on the drain hose and hang hose back on the rear of the machine.

CAUTION

To prevent odors in the recovery tank, remove the vacuum head when machine is not in operation to allow air to circulate.

MAINTENANCE OF WET & DRY VACUUM

MAINTENANCE

To keep the machine performing well for many years, please follow the following maintenance procedures.

WARNING

Always confirm that the machine is unplugged prior to performing any maintenance or repairs.

1. Drain and rinse recovery tank after each use.
2. Clean float shut-off after each use.
3. Check bag to see if it is full after each use.
Replace bag when it is 3/4 full.
4. Clean outside of machine with a mild cleaner.
5. Check power cord for any damage. If any .
6. Clean squeegee blades with a cloth.

WARNING

Do not use your fingers to wipe the blades!

7. Check vacuum hose for holes and clogs.
8. Lubricate wheels, casters and axles with a water resistant lubricant every month.
9. Check machine for loose or missing nuts and bolts, and replace as necessary.

WARNING

After each use in a wet pick-up application, remove the GV25014 "Bubble Buster" blue nylon foam suppression bag and rinse it with clean water. This will aid in preventing any build-up which can reduce air flow.

STORAGE

1. Unplug machine from power source.
2. Store in upright position in a dry area.
3. Store with squeegee assembly off the ground.
4. Store with vacuum head off unit so that tank may breathe.

MODEL 261750 - VACUUM ASSEMBLY

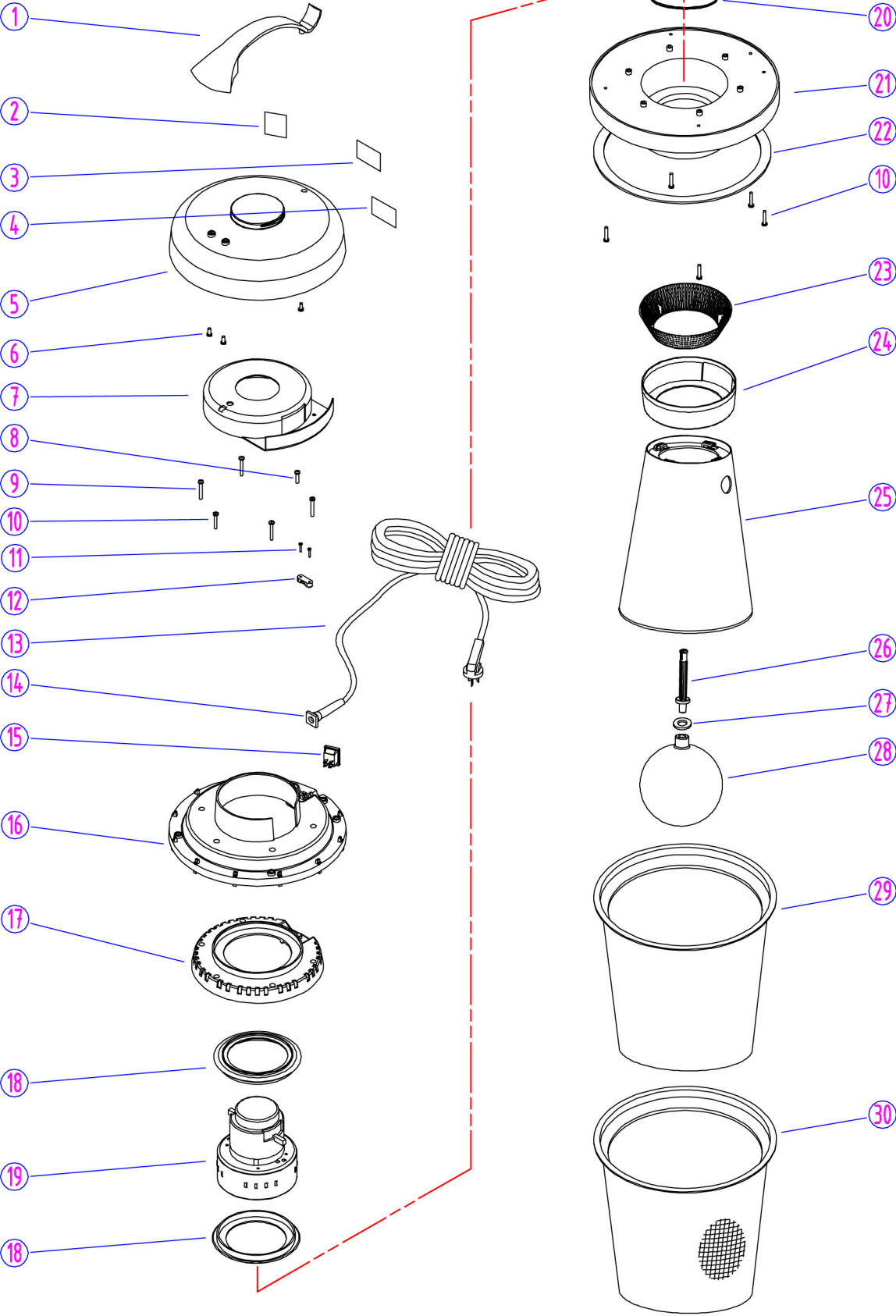

MODEL 261750 - VACUUM PARTS LIST

DIA No.	Part Number	Description	NO Req'd
1	GT10004	GRIP, HANDLE	1
2	VF40994	SCREW, SELF-TAPPING, ST, M4 X 16	3
3	VA21544A	WASHER, PLAIN, M4 X M12 X 1	1
4	VA20453	SCREW, M8 X 20	6
5	GT10003B	WASHER, LOCK, M5 X M11 X 28	6
6	GT13001	PLUG, EXPANSION	1
7	GT10019	WASHER, PLAIN, M8 X M20 X 2	8
8	GT13004	ST5 x 20, PH	1
9	GT13034	ST5 x 50, PH	4
10	GT13033	ST5 x 44, PH	6
11	VA13470	ST3 x 16, PH	2
12	VA21517	CLAMP, BLOCK	1
13	VA65001	CABLE, POWER	1
14	VA21521	GROMMET, POWER CORD	1
15	VA91346	ON/OFF SWITCH	1
16	GV15002	MOUNTING COVER, MOTOR	1
17	FC25002A	MOUNTING PLATE, MOTOR	1
18	VA41032	GASKET, MOTOR	2
19	ZD49000A	VAC MOTOR, 115V	1
20	GV25002	SEAL PLATE	1
21	GV15004A	MOUNTING BASE, MOTOR	1
22	GV15006	GASKET, MOUNTING PLATE	1
23	GV25010	FILTER SCREEN	1
24	GV25013	WATER GUARD	1
25	GV25006	TRUMPET	1
26	GV25003	POLE, BALL	1
27	VF14090	"O" RING	1
28	GV25009	BALL	1
29	GV0014	VACUUM FILTER ASSY	1
30	GV25014	BUBBLE BUSTER	1

MODEL 261750 - TANK ASSEMBLY

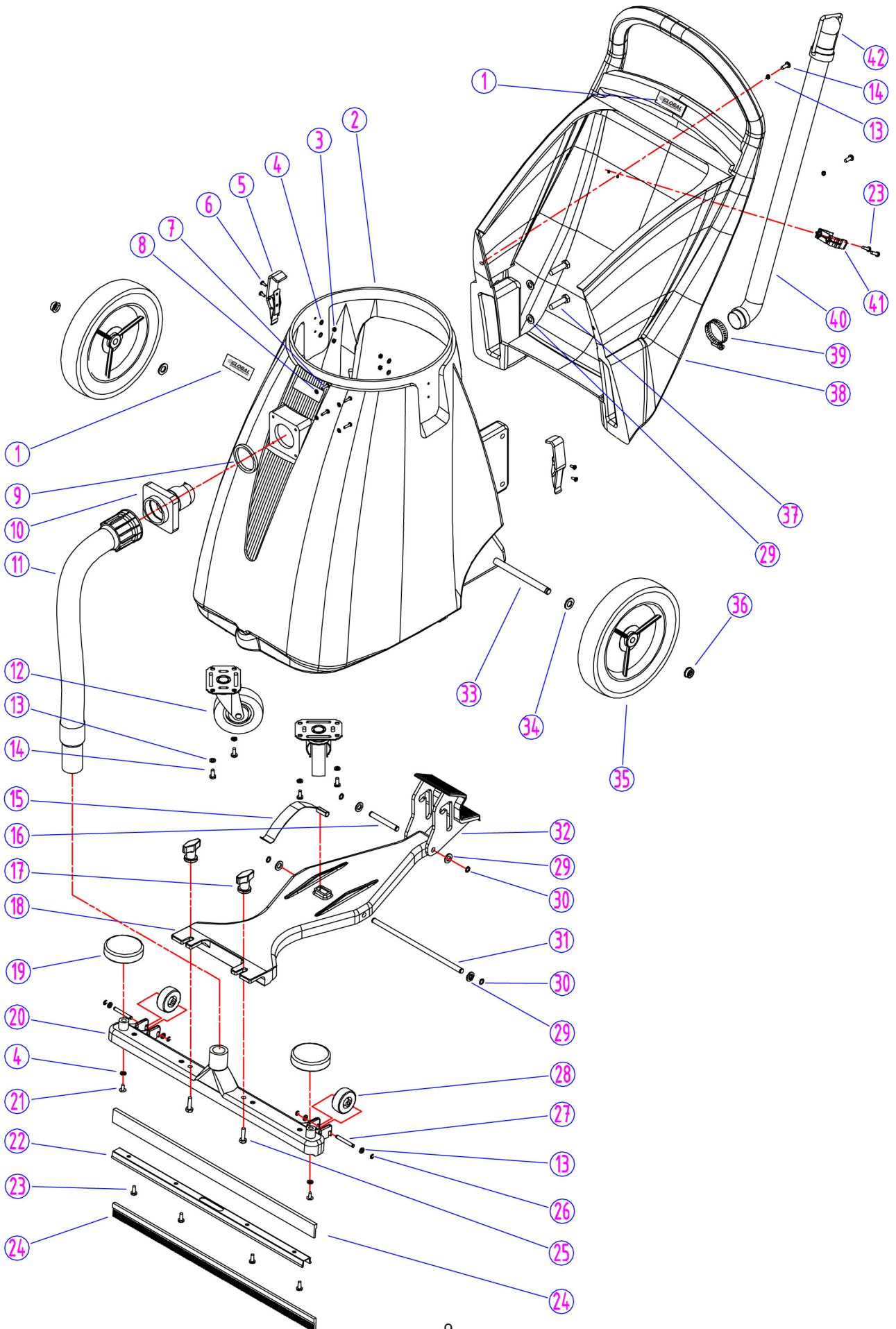

MODEL 261750 - TANK PARTS LIST

DIA No.	Part Number	Description	NO Req'd
1	VF47035A	LABEL	2
2	VA75001	TANK	1
3	GT13022	NUT, M5, NYLON INSERT	4
4	VF13474A	WASHER	6
5	VA21595	CATCH	2
6	VA14010	SCREW, M5 x 20	4
7	VA14004	SELF-TAPPING SCREW, ST4 x 20	4
8	VA13483	WASHER	4
9	VA21514	GASKET	1
10	VA21513A	INTAKE	1
11	VA85018	HOSE ASSEMBLY	1
12	VA91342	3.5" CASTER	2
13	VF13600	WASHER	10
14	VF13495	SCREW, M6 x 16	6
15	VA75005	LEAF SPRING	1
16	VA75013	AXLE	1
17	VA85003	KNOB	2
18	VA75006	MOUNTING PLATE, PICK-UP TOOL	1
19	VA75007	BUMPER	2
20	VA85002	BODY, PICK-UP TOOL 24"	1
	VA75008	BODY, PICK-UP TOOL 30"	1
21	VA13471	SELF-TAPPING SCREW, ST5 x 10	2
22	VA85001	CLAMP, BLADE, 24"	1
	VA75009	CLAMP, BLADE, 30"	1
23	VV20501	SCREW, M5 x 14, PH	6
24	VA85007	BLADE, 24"	2
	VA75010	BLADE, 30"	2
25	VA13491	SCREW, M8 x 25	2
26	VA85005	LOCK	4
27	VA85004	AXLE, WHEEL	2
28	VA91345-8	WHEEL, 2"	2
29	VF13516	WASHER	8
30	VA14001	LOCK	4
31	VA75011	AXLE, MOUNTING PLATE	1
32	VA75012	PEDAL	1
33	VA75003	AXLE, PEDAL	1
34	VV60113S	WASHER	2
35	VA75004	10" WHEEL	2
36	VV10011	CAP, AXLE, WHEEL	2
37	VA14002	SCREW, M10 x 50	6
38	VA75002	HANDLE	1
39	VV10113	CLAMP 2"	1
40	VA93208A	DRAIN HOSE	1
41	GV70034	CLAMP, DRAIN HOSE	1
42	VA20104A	PLUG DRAIN HOSE	1

MODEL 261750 - ACCESSORIES

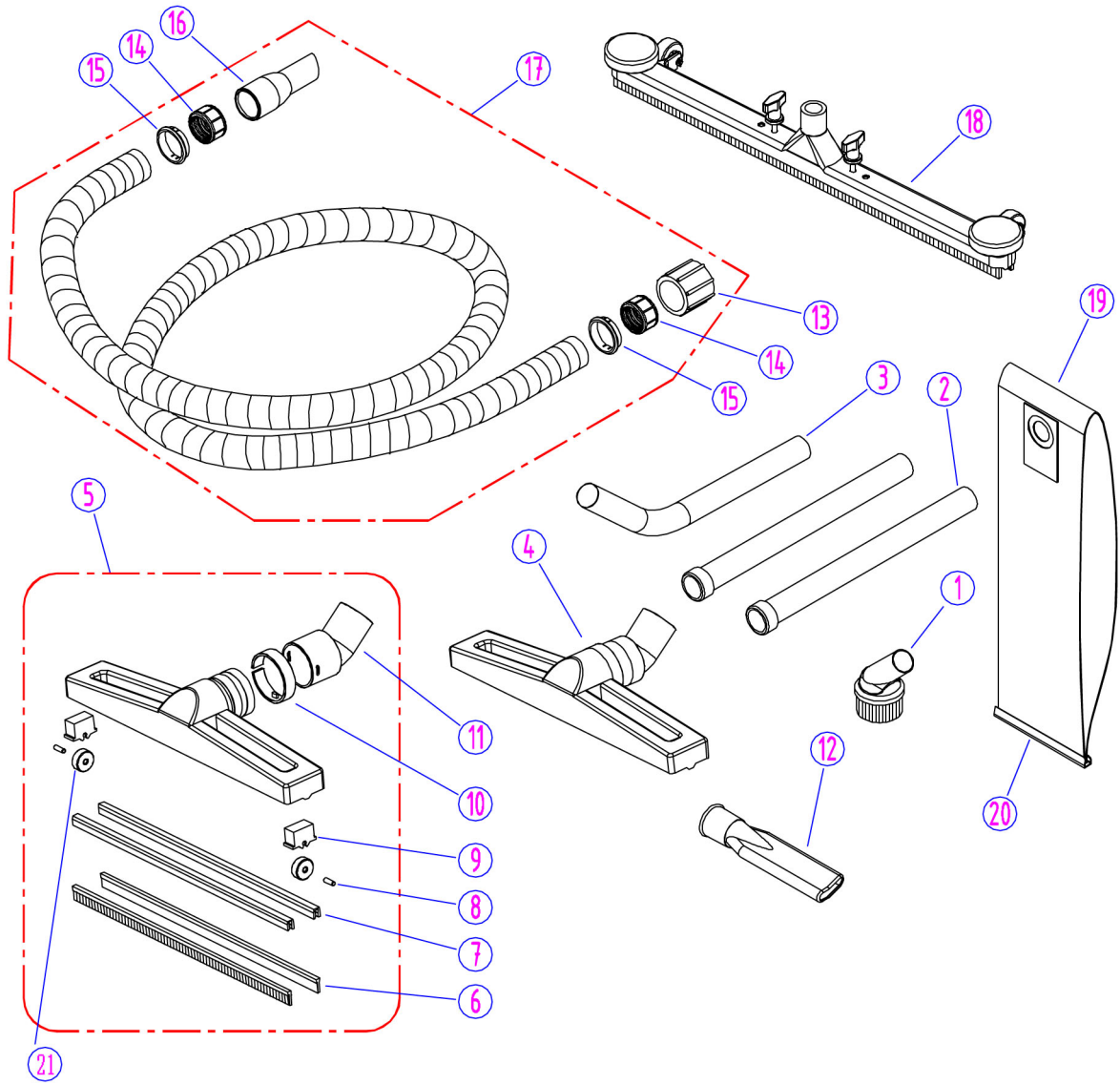

MODEL 261750 - ACCESSORIES PARTS LIST

DIA No.	Part Number	Description	NO Req'd
1	VA20803	DUSTING TOOL	1
2	VA20248	TUBE	2
3	VA20209	WAND	1
4	GV0040-D	DRY PICK-UP TOOL	1
5	GV0040-W	WET PICK-UP TOOL	1
6	VA20207-8	RUBBER BLADES, 400mm	2
7	VA20207-5A	SEAT, BLADE, 400mm	2
8	VA20413	PIN, WHEEL	2
9	VA20207-4	SEAT, WHEEL	2
10	VA20207-3	CLIP, FLOOR TOOL ADAPTER	1
11	VA20207-2	FLOOR TOOL ADAPTER (38mm)	1
12	VA20806	CREVICE TOOL	1
13	VA20201	MACHINE END	1
14	VA20202	THREADED INSERT	2
15	VA20203	CLIP RING	2
16	VA20206	ANGLED HOSE END, 38mm	1
17	VA20288	HOSE ASSY	1
18	VA00001	24" FRONT MOUNT SQUEEGEE ASSY	1
	261751	30" FRONT MOUNT SQUEEGEE (OPTIONAL) ASSY	1
	VA00005	24" DRY PICK-UP TOOL ASSY (OPTIONAL)	1
19	VA75020	CLOTH BAG, DUST (OPTIONAL)	1
20	VA75020-1	CLIP, CLOTH BAG (OPTIONAL)	1
21	VA20246	ROLLER	2

MODEL 261750 - WIRING DIAGRAM

