



342 N. Co. Rd. 400 East
Valparaiso, IN 46383
219-464-8818 • Fax 219-462-7985
www.heatwagon.com

Installation and Maintenance Manual

Please retain this manual for future reference.

950H(L)

*Construction
Heater*



NRTL
ANSI Z83.7
CONST. HTR

For your safety: Do not use this heater in a space where gasoline or other liquids having flammable vapors are stored.

CONSTRUCTION HEATER GENERAL HAZARD WARNING:

Failure to comply with the precautions and instructions provided with this heater, can result in death, serious bodily injury and property loss or damage from hazards of fire, explosion, burn, asphyxiation, carbon monoxide poisoning, and/or electrical shock.

Only persons who can understand and follow the instructions should use or service this heater.

If you need assistance or heater information such as an instruction manual, labels, etc., contact your local Heat Wagon dealer or the manufacturer.

W A R N I N G

Fire, burn, inhalation, and explosion hazard. Keep solid combustibles, such as building materials, paper or cardboard, a safe distance away from the heater as recommended by the instructions. Never use the heater in spaces which do or may contain volatile or airborne combustibles, or products such as gasoline, solvents, paint thinner, dust particles or unknown chemicals.

Not for home or recreational vehicle use!

IMPORTANT INFORMATION! READ FIRST

The heater is designed for use as a construction heater under ANSI Z83.7a-1993. The primary purpose of construction heaters is to provide temporary heating of buildings under construction, alteration, or repair and to provide emergency heat. Properly used, the heater provides safe, economical heating. Products of combustion are vented into the area being heated.

The heater **IS NOT** designed as an Unvented Gas Fired Room Heater under ANSI-Z21.11.2 and **SHOULD NOT** be used in the home.

ANSI A119.2(NFPA 501C)-1987 Recreational Vehicle Standard prohibits the installation or storage of LP-gas containers even temporarily inside any recreational vehicle. The standard also prohibits the use of Unvented Heaters in such vehicles.

NFPA-58 1989 STANDARD FOR THE STORAGE AND HANDLING OF LIQUEFIED PETROLEUM GASES AND THE NATURAL GAS AND PROPANE INSTALLATION CODE, CSA B149.1

Use of the heater must be in accordance with this Standard and in compliance with all governing state and local codes. Storage and handling of propane gas and propane cylinders must be in accordance with standard for the storage and handling of liquified petroleum gases, ANSI/NFPA 58 and CSA B149.1, natural gas and propane installation code and all local governing codes.

We cannot anticipate every use which may be made for our heaters. **CHECK WITH YOUR LOCAL FIRE SAFETY AUTHORITY IF YOU HAVE QUESTIONS ABOUT LOCAL REGULATIONS.**

Other standards govern the use of fuel gases and heat producing products in specific applications. Your local authority can advise you about these.

FOR YOUR SAFETY

DO NOT USE THIS HEATER IN A SPACE WHERE GASOLINE OR OTHER LIQUIDS HAVING FLAMMABLE VAPORS ARE STORED OR USED.

Installation and Maintenance Manual Model 950H(L) Construction Heater

Table of Contents:

	Page
Specifications	4
Installation	5
Proper Set Up	6
Hose Sizing	6
Cord Sizing	6
Operating Instructions	8
Sequence of Component Operation	9
Trouble Shooting	10
Preventive Maintenance	11
Parts Breakdown	12-14
Wiring Diagrams	15-16

WARRANTY

All new Heat Wagon and Sure Flame heaters and fans are guaranteed against defective materials and workmanship for one (1) year from invoice date.

Warranty repairs may be made only by an authorized, trained and certified Heat Wagon dealer. Warranty repairs by other entities will not be considered. Warranty claims must include model number and serial number.

LIMITATIONS

Warrant claims for service parts (wear parts) such as spark plugs, igniters, flame rods will not be allowed. Diagnostic parts such as voltage meters and pressure gauges are not warrantable.

Evidence of improper fuel usage, fuel pressures outside of manufacturer's specification, poor fuel quality, and improper electric power, misapplication or evidence of abuse may be cause for rejection of warranty claims.

Travel time, mileage and shipping charges will not be allowed. Minor adjustments of heaters are dealers' responsibility. Defective parts must be tagged and held for possible return to the factory for 60 days from date of repair. The factory will provide a return goods authorization, (RGA) for defective parts to be returned.

No warranty will be allowed for parts not purchased from Heat Wagon.



342 N. Co. Rd. 400 East • Valparaiso, IN 46383
219-464-8818 • 888-432-8924 • Fax 800-255-7985
www.heatwagon.com

DESIGN RELATED SAFETY FEATURES

- 1) **FLAME FAILURE**
The electronic safeguard control shuts off the gas supply in .8 seconds if flame is lost to prevent raw gas from leaving the heater.
- 2) **OVERHEATING**
The totally enclosed motor is protected by thermal overload. A high temperature limit switch is mounted in the control box.
- 3) **COMPLETE VISUAL/SELF DIAGNOSIS LIGHTS**
- 4) **BLOCKED AIR SUPPLY**
An airflow switch detects the differential pressure in the combustion chamber and shuts off the gas flow when airflow is insufficient.
- 5) **LOCKING GAS SELECTOR LEVER**
To avoid over firing of the heater and damage to property, make sure the lever is locked in position when using propane.
- 6) **LOW SHELL TEMPERATURE**
The Model 950HS is designed with a burner heat shield to keep the outside shell cool for added safety in the work place.
- 7) **DURABLE CONSTRUCTION**
The Model 950HS uses a heavy gauge steel housing and a stainless steel burner for long life and consistent performance.

NOTE: In order to maintain the highly efficient combustion of the heater, the combustion chamber must remain as manufactured. Any change or distortion could alter the fuel/air mixture and create excessive products of combustion.

SPECIFICATIONS

Model No. 950H & 950HL

Designed to ANSI Z83.7-1993 Standard Construction Heater

Gases:	Natural or Propane		
Capacity:	950,000 Btu/h maximum, 400,000 Btu/h minimum LP 650,000 Btu/h minimum Natural Gas		
Orifice Size:	32 DMS (x17)		
Blower:	7,000 CFM		
Electrical Rating:	120V 60Hz 15 amps, single phase		
Minimum Temperature Rating:	Minus 20 degrees F		

Gas Supply:	Inlet Pressure		Hi Fire	Lo Fire
	Max PSI	Min PSI	W.C.	W.C.
Propane	10	1	8.6"	1.4"
Natural Gas	10	3	2.8"	1.4"

Note: Min. Inlet pressure of 9"W.C. can be achieved by removing the 11SV08 Regulator (see page 13, item #4).

Inlet Connection:

Model 950HL	1/4" FNPT
Model 950H	1-1/4" FNPT

Maximum Duct Length Straight: 100 ft @ 22" diameter

SP 1" @ 5000 CFM

Weight (approximate): 360 lbs.

INSTALLATION

The Heat Wagon Model 950H(L) is a direct fired gas heater intended to be used primarily for the temporary heating of building under construction, alteration, or repair. Since all the products of combustion are released into the area being heated, it is imperative that adequate ventilation is provided. The flow of supply air and combustion gases must not be obstructed in any way.

1. The heater is designed for indoor or outdoor installation in a horizontal position. Allow the following clearances from any combustible material or fuel containers.

Front Outlet:	20 feet	Sides:	2 feet
Intake:	2 feet	Top:	4 feet

Also make sure that no flammable vapors are present in the space where the heaters is being used.

2. The heater should be inspected before each use, and at least annually by a qualified service person.
3. The hose assembly must be inspected prior to each use of the heater. If it is evident that there is excessive abrasion or wear, or the hose is cut, it must be replaced prior to the heater being put into operation. The replacement hose assembly shall be that specified by the manufacturer.
4. When connecting the heater to a natural gas or propane supply line ensure that the pressure at the heater inlet is within the specified range. Excessive pressure over (14" W.C.) will damage the controls and void the warranty.
5. Connect the hose assembly to the heater gas inlet elbow. The 950H elbow has a 1-1/4" female NPT thread, 950HL elbow has a 1/4" female NPT thread. Ensure that the hose assembly is protected from traffic, building materials, and contact with hot surfaces.
6. After installation, check hose assembly for gas leaks by applying a soap and water solution to each connection.
7. Connect the heater to an adequate 115 volt electrical supply as specified on the rating plate. For protection against shock hazard the supply cord should be plugged directly into a properly grounded three-prong receptacle.

EXTENSION CORDS:

Properly Wired and Grounded

Use #14 wire up to 100'

Use #12 wire up to 200'

Use #10 wire up to 300'

8. Replacement parts are available from any Heat Wagon distributor or by calling 1-888-432-8924 for parts information.

MODEL 950H & 950HL

PROPER SET UP:

Model 950HL is a liquid withdrawal unit. This unit will use 11 gal of LP per hour on high fire. Use at least (1) 200 gal. withdrawal tank. When using Propane turn the fuel selector valve (located on the lower manifold) to the **Propane** position. This will insure 18 hours of continuous operation. Since the 950HL is a Liquid Propane unit, it must be set up outside of the building. Use 3/8" or 1/2" LPG approved hose or copper tube.

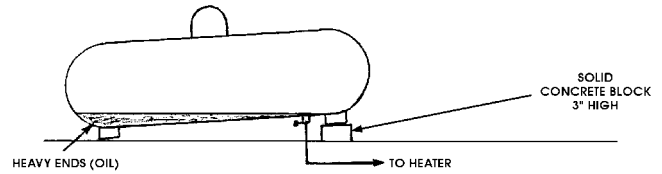

Model 950H is a Vapor Propane or Natural Gas unit. When using Propane turn the fuel selector valve (located on the lower manifold) to the **Propane** position. When using **Natural Gas** turn the selector valve to the **Natural Gas** position. This unit can be set up indoors or out.

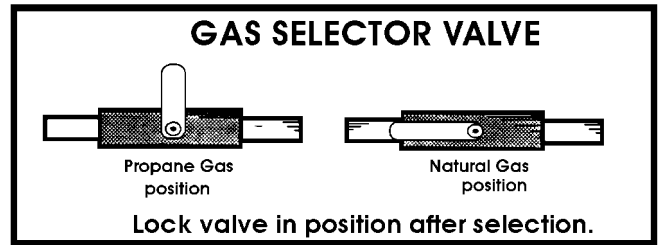

VAPOR PROPANE QUICK
REFERENCE HOSE
CHART

Hose Length in Feet	BTU 1 Million	
	1/2PSI	10PSI
10	1-1/4	3/4
25	1-1/4	3/4
35	1-1/4	3/4
50	-	3/4
75	-	3/4
100	-	3/4
125	-	3/4
150	-	3/4
175	-	3/4
200	-	3/4
225	-	3/4

NATURAL GAS QUICK
REFERENCE HOSE
CHART

Hose Length in Feet	BTU 1 Million			
	<1PSI	1PSI	2PSI	5PSI
10	1-1/2	1-1/4	3/4	3/4
25	2	1-1/4	3/4	3/4
35	2	1-1/4	3/4	3/4
50	2	1-1/4	1-1/4	3/4
75	2	1-1/4	1-1/4	3/4
100	2	1-1/4	1-1/4	3/4
125	2-1/2	1-1/2	1-1/4	3/4
150	2-1/2	1-1/2	1-1/4	3/4
175	2-1/2	1-1/2	1-1/4	3/4
200	2-1/2	1-1/2	1-1/4	3/4
225	2-1/2	1-1/2	1-1/4	3/4

VAPORIZATION RATES IN BTUH @ 0 DEG. F							
TANK SIZE	NUMBER OF TANKS MANIFOLDED	PERCENTAGE OF TANK FILLED					
		10%	20%	30%	40%	50%	60%
250	1	12,690	169,200	197,400	225,600	253,800	282,000
	2	279,180	372,240	434,280	496,320	558,360	620,400
	3	486,027	648,036	756,042	864,048	972,054	1,080,060
500	1	198,135	264,180	308,212	352,240	396,270	440,300
	2	435,897	581,196	687,066	774,928	871,794	968,660
	3	758,857	1,011,809	1,180,451	1,349,079	1,517,714	1,686,349
1000	1	354,240	472,320	551,040	629,760	708,480	787,200
	2	779,328	1,039,104	1,212,288	1,385,472	1,558,656	1,731,840
	3	1,356,739	1,808,985	2,110,483	2,411,980	2,713,478	3,014,976

NOTE: USE FOLLOWING MULTIPLIERS FOR OTHER AIR TEMPERATURES

- For -10° F multiply x 0.50
- For + 10°F multiply x 1.5
- For +20°F multiply x 2.0
- For +40°F multiply x 3.0
- For +50°F multiply x 3.5
- For +60°F multiply x 4.0

INSTALLATION USING A PROPANE SUPPLY TANK(S)

- 1) When installing the heater for use with propane gas, set the gas selector to “Propane” and lock in position.
- 2) The propane supply system must be set up for vapor withdrawal from the operating tank(s). Liquid Propane can cause the heater to overfire and will damage valve train components.
- 3) The heater must be located at least 6 ft from any LP-Gas container, and not directed toward any LP-Gas container within 20 ft.
- 4) Minimum Tank Size(vapor propane) Outdoor Temperature
500 Gal. Above +25°F
1000 Gal. +25°F to + 10° F
2 x 1000 Gal. Below +10°F
- 5) The installation must conform with local codes, or in the absence of local codes, with the Standard for Storage and Handling of Liquefied Petroleum Gasses ANSI/NFPA 58.
- 6) Turn off the propane supply valve at the tank(s) when the heater is not in use.
- 7) When the heater is to be stored indoors the propane tank(s) must be disconnected from the heater and the tank(s) stored in accordance with Chapter 5 of the above National Standard.

COMMON INSTALLATION AND OPERATIONAL PROBLEMS

- 1) **LOW VOLTAGE AT THE HEATER**
This is one of the most common problems and is usually the result of the supply cord having too small a wire gauge for its length, or low voltage at the power source. Low voltage results in the motor overheating, burnt relay contacts, or a relay that will not make contact. Check voltmeter on heater before start-up.
- 2) **SUPPLY LINE TOO SMALL**
See Reference Hose Chart page 6.
- 3) **INSUFFICIENT VAPORIZATION AT SUPPLY**
Normally caused by undersized supply tank.
- 4) **IMPROPER GAS SUPPLY PRESSURE**
Usually a result of propane supply pressure being too high because of improper or lack of regulation or too low of natural gas pressure at meter.
- 5) **DIRTY GAS SUPPLY**
Dirty gas can cause strainers to plug or form a build-up in the burner orifice.
- 6) **LACK OF PREVENTIVE MAINTENANCE**
Heaters must be cleaned as required, especially when used in a dirty environment.
- 7) **IMPROPER SUPPLY OF FRESH AIR**
It is strongly recommended that the intake air of the heater be taken from outside the enclosed area. This provides a slight pressurization and prevents any problems associated with recirculation of products of combustion.

ON-SITE SAFETY PROBLEMS

1) SHORTING OUT OF DEFECTIVE COMPONENTS

This is a very common problem which saves short term expense at the risk of a large future cost. Any heaters found in this condition should be removed immediately.

2) IMPROPER ENCLOSURES

When heaters are installed partially to the outside for fresh air intake, strict adherence must be made to the minimum clearance to combustibles given on the instruction plate. Wood framing around a heater can cause a safety hazard.

3) SUPPLYING LIQUID PROPANE TO HEATER NOT EQUIPPED WITH A BUILT IN VAPORIZER

This problem has occurred upon initial start-up. To minimize the damage, shut off the gas supply and let the heater run until all of the liquid in the lines had been consumed.

OPERATING INSTRUCTIONS

- 1) Set the **gas selector valve** for fuel being used. Check for proper gas pressure.
- 2) Open **manual shut-off valve** on heater.
- 3) Connect power supply (115 volt). Check voltmeter to confirm full voltage.
- 4) Slowly open shut-off valve at gas meter or propane tank. Check for leaks.
- 5) Push up the "ON" switch.
- 6) Set **thermostat** for desired room temperature.
- 7) To stop, turn **thermostat** down or push down the stop switch.
(Burner will turn off; after 10 seconds fan will turn off.)
- 8) Close **manual shut-off valve** on heater.

NOTE: If the heater will be shut down over night, close valve at fuel supply first and burn all gas out of line.

The appliance area should be kept clear and free from combustible materials, gasoline, and other flammable vapors and liquids.

Ensure that the flow of supply air and combustion gases is not obstructed.

The installation and operation of the heater shall comply with the code requirements specified by the authorities having jurisdiction.

General criteria for the use of construction heaters may be found in the applicable sections of American National Standard A-10.10-1987, Safety Requirements for Temporary and Portable Space Heating Devices and Equipment Used in the construction industry.

THE INSTALLATION AND MAINTENANCE OF THE HEATER MUST BE ACCOMPLISHED BY A QUALIFIED SERVICE PERSON.

MODEL 950H & 950HL
SEQUENCE OF COMPONENT OPERATION

- 1) **POWER SUPPLY**
Plug the heater into a 120 Volt grounded receptacle. Power is now at the 20 amp fuse and the 3 amp circuit breaker. Power light illuminates.
- 2) **20 AMP FUSE & 3 AMP BREAKER**
If the circuit breaker and fuse are good there will be power at the thermostat and at the motor relay (normally open). Fuse light illuminates.
- 3) **ON SWITCH**
With the fan switch ON it sends power to the OFF switch and the control relay. (Normally open terminal and it's solenoid coil.)
- 4) **CONTROL RELAY**
After receiving power from the OFF switch, the relay closes, a loop between the 3amp breaker and the (NC) OFF Switch.
- 5) **OFF SWITCH**
Power is sent from OFF Switch to (L1) terminal of DSI control and the (COM) terminal of the thermostat.
- 6) **THERMOSTAT**
When the thermostat calls for heat there will be power at (TH) terminal of the DSI control and Air Flow Switch (COM) Terminal.
- 7) **DSI CONTROL**
Sends power from (IND) terminal to coil of the motor relay.
- 8) **MOTOR RELAY**
With its coil energized it closes its contacts, sending power to the fan motor.
- 9) **FAN MOTOR**
Turns the fan blade causing the air flow switch to close.
- 10) **AIR FLOW SWITCH**
Received its power from the thermostat and sends the power to the indicator light and the DSI control (PSW) terminal.
- 11) **DSI CONTROL**
Sends power from (IND) terminal to coil of the motor relay.
- 12) **HI TEMPERATURE LIMIT SWITCH**
This switch has normally closed contacts, it sends power to the gas solenoid valves. Lo valve and Hi valve lights illuminate.
- 13) **GAS SOLENOID VALVE**
With their coils energized, the valves open, gas passes through to the burner and ignites.
- 14) **FLAME SAFEGUARD CONTROL**
This is now sensing flame through the flamerod and the spark stops. The heater is operating.
- 15) **THERMOSTAT**
When it is satisfied, the contacts open taking power away from the (TH) terminal of the DSI control, the gas valves close, and the built-in fan delay timer is activated.
- 16) **BUILT-IN FAN DELAY TIMER ON DSI CONTROL**
This will operate the fan motor for approximately 10 seconds and turns the fan off.

TROUBLE SHOOTING

DIRECTIONS: Find the specific **symptom**. refer to the **Sequence of component Operation Guide**. Check the components listed with a **voltmeter** for proper operation as described. Replace any components not operating correctly.

Fan will not start when ON switch & thermostat are ON.

- Check sequences 1 through 8 (Page 9).

Fan runs, no spark for ignition.

- Check sequences 10 and 11 (Page 9).
- Check continuity of igniter leads. Replace if shorted or broken.
- Check igniter for carbon buildup, gap spacing (1/8"), secure mounting.
- Replace igniter if porcelain is cracked or if electrodes are rubbery.

Have spark but no flame.

- Check sequences 11, 12 and 13 (Page 9).
- Check for gas pressure on the manifold gauge, if gas is present clean the port holes in burner.

Flame occurs but burner locks out after a few seconds.

- Check the flame rod, if the porcelain is cracked or the electrode is rubbery, replace it.
- If the 1st step checks out, replace the DSI control.

Flame occurs but small.

- Check proper pressure at manifold gauge. If yes:
 - A) Clean port holes in burner.
 - B) Check proper position of Gas selector valve (For Natural Gas).
- Not enough pressure at manifold gauge:
 - A) Check fuel supply.
 - B) Check liquid strainer for restriction (950HL).
 - C) Check for restriction at high pressure regulator.
 - D) Check for restriction at solenoid valves.

Fan does not shut off when thermostat turns off burner.

- Fan should run for 10 to 15 seconds after burner shuts off. Replace DSI control if fan runs over 30 seconds.

Fan runs, no fuel or spark.

- Check to see if the Air Switch light is on, if not, clean or adjust the airflow switch.

PREVENTATIVE MAINTENANCE

Heat Wagon Construction Heaters are built to withstand the rigors of operating on construction sites, for mining applications, and a multitude of other locations. To maintain the reliable performance required it is necessary to do a certain amount of regular maintenance.

1) CHECK POWER CORD

- A. Insulation not frayed or cracked.
- B. Ground peg is there on male end.
- C. Polarity is correct (Black wire on fuse, white wire on neutral block).

2) CHECK ALL WIRING FOR PROPER CONNECTIONS

3) CHECK MOTOR RELAY

- A. If it buzzes, clean contacts or replace.
- B. Check for voltage drop through contacts, if its more than 2 volts replace.

4) CHECK AIR FLOW SWITCH

- A. Blow out the inlet tube and negative pressure fitting.
- B. Adjust the switch, light on control panel stays on if the heater is bumped and shuts off if fan inlet is blocked.

5) CLEAN THE BURNER

- A. Clean out the port holes (gas outlet).
- B. Clean air mixture holes.

6) CHECK IGNITER/SENSOR

- A. Move sensor probe; if rubbery, replace.
- B. If stiff; clean and regap igniter at 1/8".

7) CHECK FOR GAS LEAKS

- A. Operate the heater, (with leak detector or soapy water) check all pipe connections for leaks.

8) TIGHTEN ALL BOLTS

- A. Motor mounts
- B. Fan blade
- C. Burner mount
- D. Pipe train mounts

MODEL 950H & 950HL

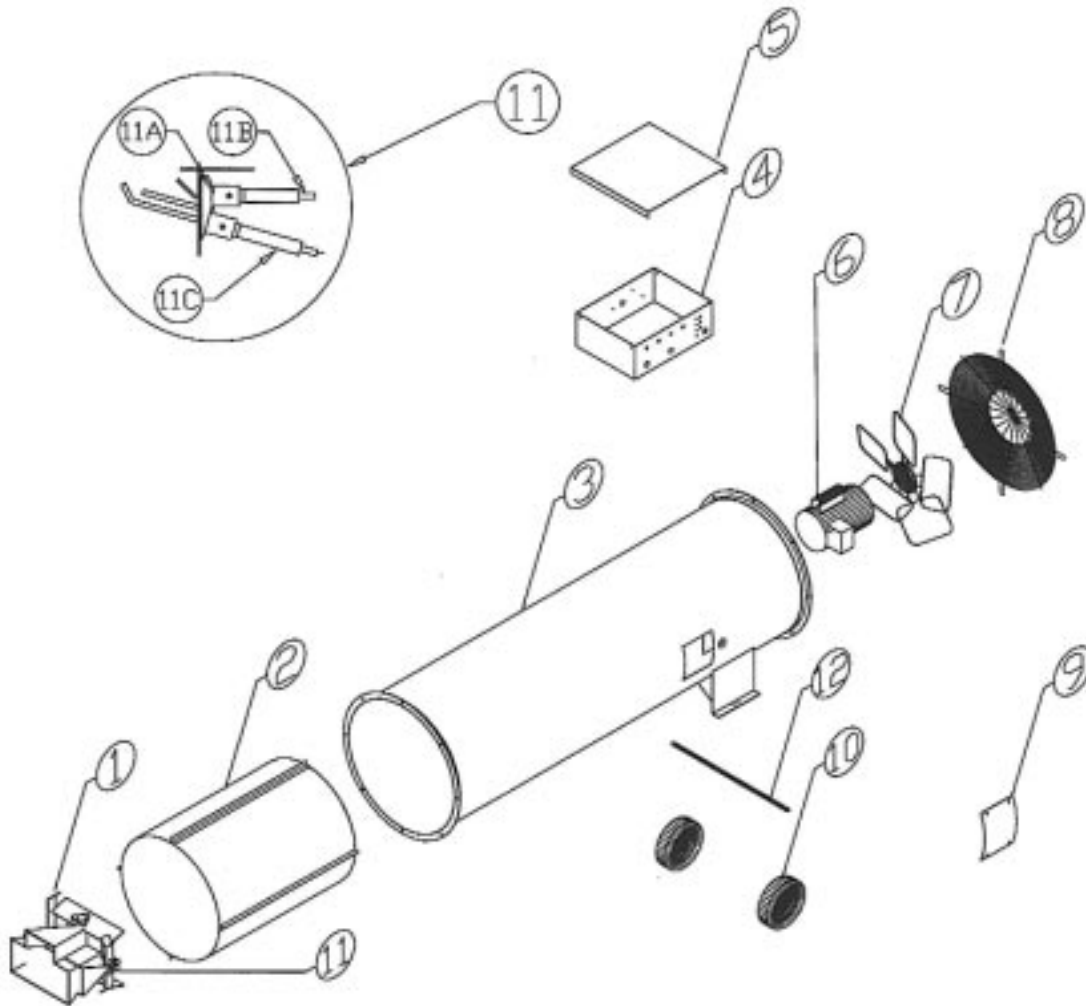

<u>Item</u>	<u>Part #</u>	<u>Description</u>
1	HWP HB1171B	Burner Complete
2	HWP HB1177C	Heat Shield
3	HWP HB950A	Heater Body Shell
4	HWP HC1083	Control Box
5	HWP HC1082	Control Box Lid
6	HWP HM1050	Motor
7	HWP HP1162	Fan Blade
8	HWP HG950A	22" Fan Guard
9	HWP HC1064	Burner Access Door
10	HWP HW1065	Wheel(950H - Non-Stackable)
11	HWP 1190310	Pilot w/Spark Rod and Flame Rod
11A	N/A	Pilot Assy. Bracket
11B	HWP 134290	Igniter
11C	HWP 136003	Flame Rod
12	HWP HW1065D	Axle(950H - Non-Stackable)

MODEL 950H & 950HS VAPOR PIPE TRAIN BREAKDOWN

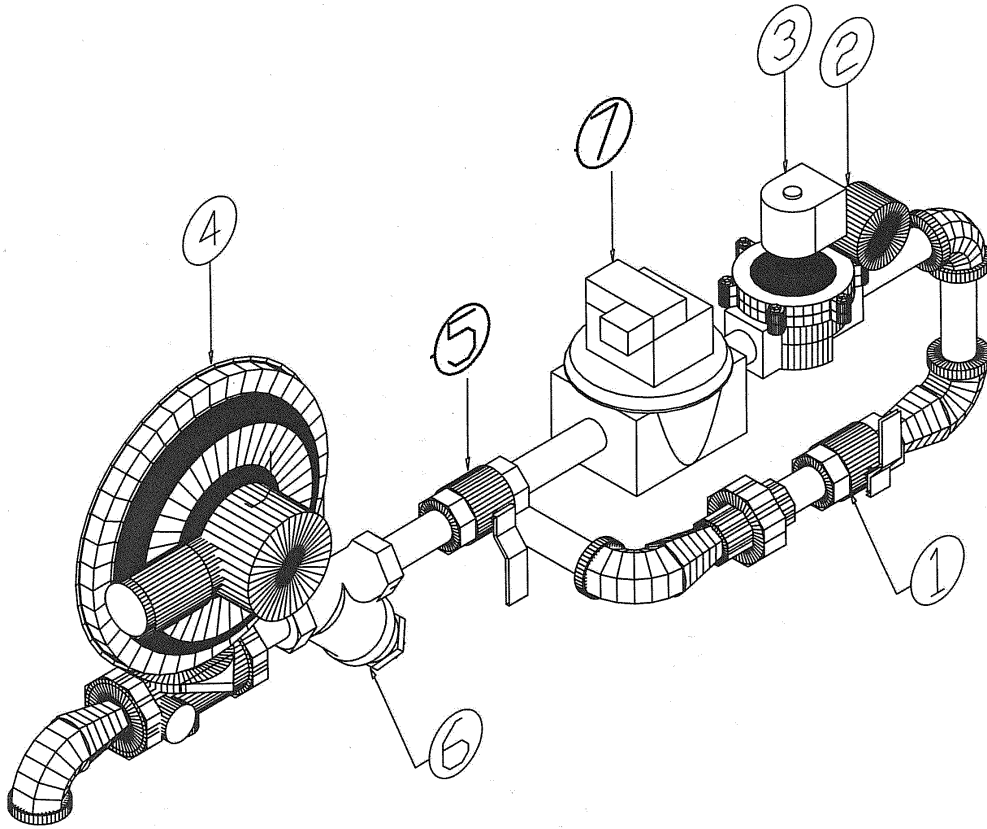

<u>Item</u>	<u>Part #</u>	<u>Description</u>
1	HWP HV1120	Gas Selector Valve 1-1/4" Locking
2	HWP HV1169	Gauge 15" W.C.
3	HWP HV1138	1-1/4" Solenoid Valve
4	ACC 11SV08	Regulator
5	HWP HV1121	1-1/4" Ball Valve
6	HWP HV1122	1-1/4" Y Strainer
7	SFP 4490	2 Stage Regulator Valve

MODEL 950 IGNITER

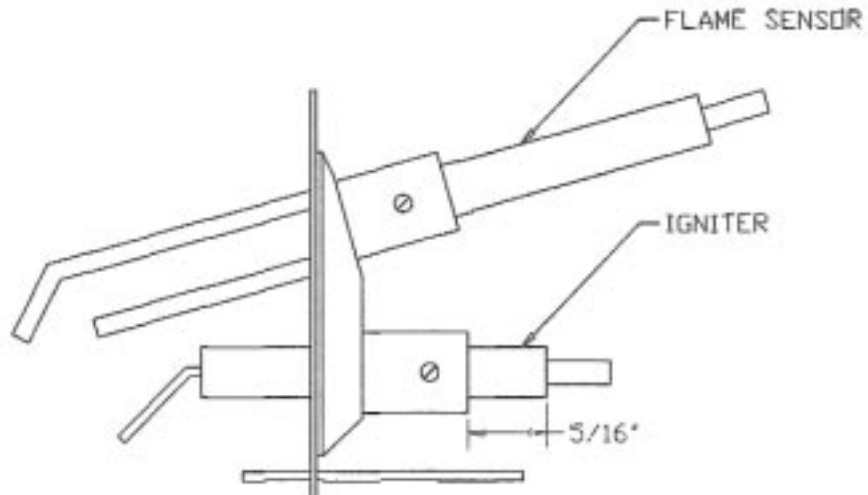

CONTROL BOX PARTS

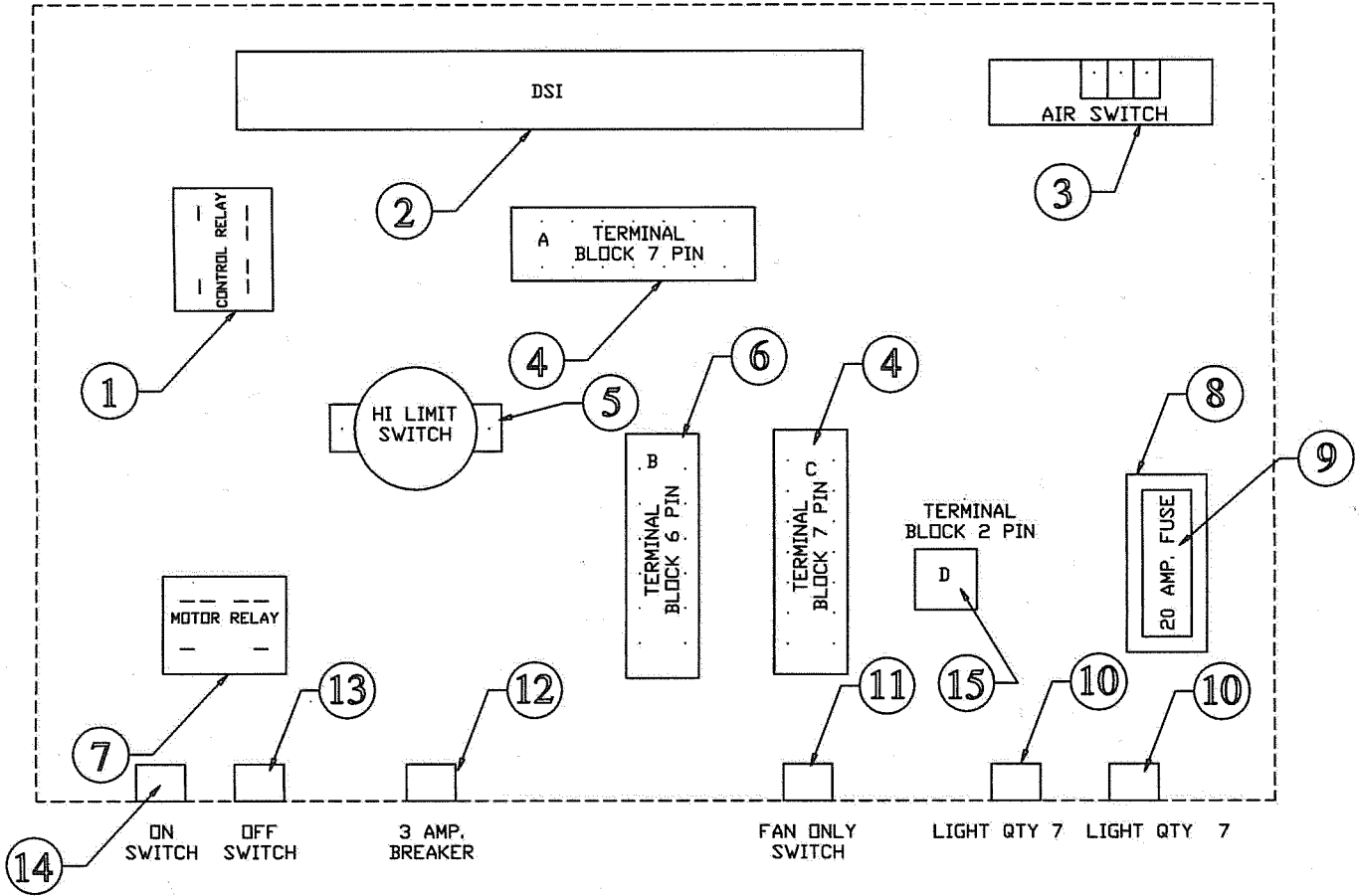

<u>Item</u>	<u>Part #</u>	<u>Description</u>
1	HWP 9264	Control Relay
2	HWP HC1001D	DSI Control
3	S1500-710	Air Switch
4	HWP HC1123	Terminal Block (A,C)
5	HWP 2446	Hi Limit Switch
6	HWP HC1123	Terminal Block (C)
7	HWP 9264	Motor Relay
8	HWP HC1122	Fuse Block
9	HWP HC1115	Fuse 20 amp
10	HWP 44130	Light
11	HWP HC1011	Fan Only Switch
12	HWP HC1019B	3amp Breaker
13	HWP HC1150	OFF Switch
14	HWP HC1149	ON Switch
15	HWP HC1123	Terminal Block (D)
16	HWP HC1120	Thermostat (w/o cord) (not shown)
17	HWP HC1020	Power cord (not shown)

950H CONTROL BOX WIRING

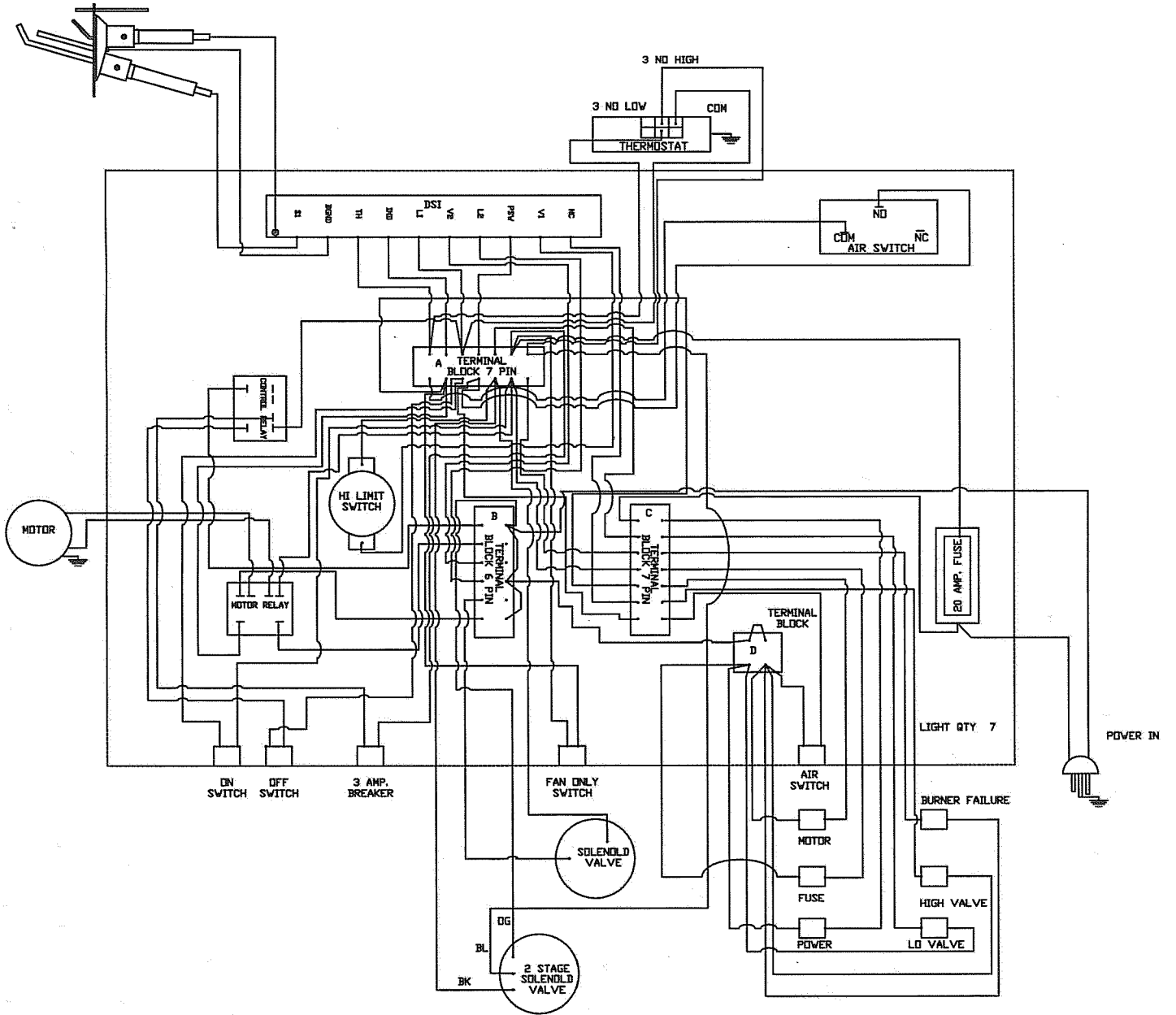

MAIN CIRCUIT DIAGRAM

