



**SURE FLAME<sup>®</sup>**

**S1505B**

**CONSTRUCTION HEATER**



Rev. 4.21 Aug 8, 2008

**SERVICE AND MAINTENANCE MANUAL No. 974-9308**  
**PLEASE RETAIN FOR FUTURE REFERENCE**

**SURE FLAME<sup>®</sup> PRODUCTS**

A DIVISION OF HAUL-ALL EQUIPMENT LTD.  
4115 - 18 Ave. N, Lethbridge, Alberta  
[www.sureflame.ca](http://www.sureflame.ca)

# S1505B Construction Heater



## GENERAL HAZARD WARNING

Failure to comply with the precautions and instructions provided with this heater, can result in death, serious bodily injury and property loss or damage from hazards of fire, explosion, burn, asphyxiation, carbon monoxide poisoning, and/or electrical shock.

Only persons who can understand and follow the instructions should use or service this heater.

If you need assistance or heater information such as an instruction manual, labels, etc. Contact the manufacturer.



## WARNING

Fire, burn, inhalation, and explosion hazard. Keep solid combustibles, such as building materials, paper or cardboard, a safe distance away from the heater as recommended by the instructions. Never use the heater in spaces which do or may contain volatile or airborne combustibles, or products such as gasoline, solvents, paint thinner, dust particles or unknown chemicals.



## WARNING

**Not for home or recreational vehicle use**

# READ THIS WARNING FIRST!

The heater is designed and approved for use as a construction heater under ANSI Z83.7-2000. The primary purpose of construction heaters is to provide temporary heating of buildings under construction, alteration, or repair and to provide temporary emergency heat. Properly used the heater provides safe economical heating. Products of combustion are vented into the area being heated.

The heater is not designed as an Unvented Gas Fired Room Heater under ANSI-Z21.11.2 and should not be used in the home.

ANSI A119.2(NFPA 501C)-1987 Recreational Vehicle Standard prohibits the installation or storage of LP-Gas containers even temporarily inside any recreational vehicle. The standard also prohibits the use of Unvented Heaters in such vehicles.

## **NFPA-58 1989 STANDARD FOR THE STORAGE AND HANDLING OF LIQUEFIED PETROLEUM GASES**

Use of the heater must be in accordance with this Standard and in compliance with all governing state and local codes. Storage and handling of propane gas and propane cylinders must be in accordance with NFPA 58 and all local governing codes.

We cannot anticipate every use which may be made for our heaters. **CHECK WITH YOUR LOCAL FIRE SAFETY AUTHORITY IF YOU HAVE QUESTIONS ABOUT LOCAL REGULATIONS.**

Other standards govern the use of fuel gases and heat producing products in specific applications. Your local authority can advise you about these.

# S1505B

## CONSTRUCTION HEATER

### FOR YOUR SAFETY

**DO NOT USE THIS HEATER IN A SPACE WHERE  
GASOLINE OR OTHER LIQUIDS HAVING  
FLAMMABLE VAPOURS ARE STORED OR USED.**

### Contents:

	Page
Specifications	5
Installation	6
Installation Using a Propane Supply Cylinder	7
Installation for Natural Gas Applications	7
Operating Instructions	8
Common Installation and Operational Problems	9
Safety Controls	9
Safety Features	10
On-Site Hazards	10
Preventative Maintenance	11
Troubleshooting Tables	12
Replacement Parts	20
Wiring Diagrams	22
Two Stage Thermostat Wiring Diagram	24
LPG - Propane Fuel Vaporization Rate	25
Maximum BTU Content (Propane)	25
Pressure & Flow Equivalents	25

# Specifications

AGA certified to ANSI Z83.7-2000 Construction Heater

Gases:	Natural or Propane
Capacity:	1,500,000 Btu/h maximum 850,000 Btu/h minimum
Orifice Size:	41 DMS (X46)
Blower:	7,000 cfm
Electrical Rating:	115 volts, 60 Hz, 9.4 amps, Single Phase
Min. Temperature Rating:	Minus 40 degrees F

## Gas Supply:

	<u>Inlet Pressure</u>		<u>Manifold Pressure</u>	
	Max W.C.	Min W.C.	Max W.C.	Min.W.C.
Propane	14"	9"	2.7"	0.75"
Natural	14"	9"	7.2"	2.0"

(Minimum inlet pressure is for purpose of input adjustment)

# Installation

The Sure Flame Model S1505B is a direct fired gas heater intended to be used primarily for the temporary heating of buildings under construction, alteration, or repair. Since all the products of combustion are released into the area being heated, it is imperative that adequate ventilation is provided. The flow of supply air and combustion gases must not be obstructed in any way. Do not use the heater with ductwork as this will restrict the flow of supply air.

- 1 Install the heater in a horizontal position at least 6 ft. (1.83 m) from any LP-gas container, and allow the following clearances from any combustible materials:

Front Outlet:	20 feet	Sides:	2 feet
Intake:	2 feet	Top:	4 feet

Front Outlet must not be directed at any LP-gas container within 20 feet.

Also make sure that no flammable vapours are present in the space where the heater is being used.

- 2 When connecting the heater to a natural gas or propane supply line ensure that the pressure at the heater inlet is within the specified range. Please refer to Propane and Natural Gas Installation sections in this manual. Excessive pressure (over 1/2 psig) will damage the controls and void the warranty.
- 3 Visually inspect the hose assembly and ensure that it is protected from traffic, building materials, and contact with hot surfaces. If it is evident that there is excessive abrasion or wear, or the hose is cut, it must be replaced.
- 4 After installation, check the hose assembly for gas leaks by applying a water and soap solution to each connection.
- 5 Connect the heater to an adequate 115 volt electrical supply and in compliance with the *National Electrical Code, ANSI/NFPA 70*. For protection against shock hazard the supply cord should be plugged directly into a properly grounded three-prong receptacle.
- 6 In all applications install the heater in such a manner that it is not directly exposed to water, spray, rain and/or dripping water.

# Installation Using A Propane Supply Cylinder

- 1 When installing the heater for use with propane gas, set the gas selector valve to "Propane" and lock in position.
- 2 The supply container **MUST** be equipped with an LP Gas Regulator that complies with ANSI/UL 144 Standard for Pressure Regulating Valves for LP-Gas. Another regulator must be installed in the heater to reduce the pressure from this regulator down to a maximum inlet pressure of 1/2 psi.
- 3 Arrange the cylinder supply system to provide for vapour withdrawal from the operating cylinder. Supplying liquid propane to the heater is dangerous and will damage the components.
- 4 Ensure that for the surrounding temperature the size and capacity of the propane supply cylinder is adequate to provide the rated Btu/h input to the heater.
- 5 Turn off the propane supply valve at the cylinder when the heater is not in use.
- 6 The installation must conform with all local codes, or in the absence of local codes, with the Standard for the *Storage and Handling of Liquefied Petroleum Gases, ANSI/NFPA 58*.
- 7 When the heater is to be stored indoors, the propane cylinder(s) must be disconnected from the heater and the propane cylinder(s) removed from the heater and stored in accordance with the National Standard for the *Storage and Handling of Liquefied Petroleum Gases, ANSI/NFPA 58*.

# Installation For Natural Gas Applications

- 1 When installing the heater for use with natural gas, set the GAS SELECTOR VALVE to the "Natural" position.
- 2 A regulator must be installed on the heater to ensure that the pressure to the heater does not exceed 1/2 psi inlet pressure.
- 3 The installation of this heater to a natural gas supply must conform with all applicable local codes or, in the absence of local codes, with the *National Fuel Gas Code ANSI Z223.1/NFPA 54*.

# Operating Instructions

1. Set GAS SELECTOR VALVE to gas being used. The conversion shall be done by the owner or lessor of the equipment.  
**Warning:** When using propane gas, the GAS SELECTOR VALVE must be locked in position.
2. Ensure FIRING VALVE is in the "ON" position.
3. Connect power cord to a 115 volt supply.
4. Open gas supply.
5. Set thermostat to the desired temperature.
6. Push START button. After a short delay, the heater will start.  
Note: Heater will cycle between high flame, low flame, and off as required.
7. To stop: push STOP button. If heater is to remain off, disconnect power, and close gas supply.

The appliance area should be kept clear and free from combustible materials, gasoline, and other flammable vapours and liquids.

Ensure that the flow of supply air and combustion gases is not obstructed.

The installation and operation of the heater shall comply with the code requirements specified by the authorities having jurisdiction.

General criteria for the use of construction heaters may be found in the applicable sections of American National Standard A10.10-1987, Safety Requirements for Temporary and Portable Space Heating Devices and Equipment Used in the Construction Industry.

**THE INSTALLATION AND MAINTENANCE OF THE  
HEATER MUST BE ACCOMPLISHED BY A QUALIFIED  
SERVICE PERSON.**



# Common Installation And Operational Problems

## 1 LOW VOLTAGE

This is one of the most common problems and is usually the result of the supply cord having too small of a wire gauge for its length. Low voltage results in the motor overheating, burnt relay contacts, or a relay that will not make contact.

## 2 SUPPLY LINE TOO SMALL

## 3 INSUFFICIENT VAPORIZATION AT SUPPLY

Normally caused by too small size of supply tank.

## 4 IMPROPER GAS SUPPLY PRESSURE

Usually a result of supply pressure being too high because of improper or lack of regulation.

## 5 DIRTY GAS SUPPLY

Dirty gas can cause strainers to plug or form a build-up in the burner orifice.

## 6 LACK OF PREVENTATIVE MAINTENANCE

Heaters must be cleaned as required, especially when used in a dirty environment.

## 7 IMPROPER SUPPLY OF FRESH AIR

It is normally recommended that the intake air of the heater be taken from outside the enclosed area. This provides a slight pressurization and prevents any problems associated with recirculation.

## Safety Controls

Servicing of Sure Flame Construction Heaters normally involves one of several built-in safety features. The Model S1505B incorporates devices to detect the following:

### 1 LOSS OF FLAME

Gas supply is shut off if flame is lost to prevent raw gas from leaving the heater.

### 2 OVERHEATING

(a) Thermal overload protection in the motor.

(b) High temperature limit switch in the combustion chamber.

### 3 LOSS OF POWER

Total shutdown with manual reset required. Any one of the safety devices will create a loss of power situation.

### 4 BLOCKED AIR SUPPLY

A switch detects the differential pressure in the combustion chamber and shuts down when insufficient.

### 5 LOW INLET PRESSURE

A pressure switch monitors the gas inlet and closes the safety shut-off valve if pressure drops below the preset limit.

# Safety Features:

## 1 LOCKING POSITION FOR LPG ON GAS SELECTOR LEVER

Units used with LPG while the gas selector valve is positioned for Natural Gas will produce significantly more heat than the rated Btu/h. This is definitely a safety hazard.

## 2 LOW SKIN TEMPERATURE

Sure Flame Heaters are designed to have a low skin temperature. This provides added safety in the workplace.

## 3 DURABLE CONSTRUCTION

The Model S1505B uses a stainless steel burner for long life and consistent performance.

In order to maintain the highly efficient combustion of the Sure Flame Heater, the combustion chamber must remain as manufactured. Any change or distortion could alter the fuel/air mixture and create hazardous gases.

# On-Site Hazards

## 1 SHORTING OUT OF DEFECTIVE COMPONENTS

This is a very common problem which saves short term expense at the risk of a large future cost. Any heaters found in this condition should be removed immediately.

## 2 IMPROPER ENCLOSURES

When heaters are installed partially to the outside for fresh air intake, strict adherence must be made to the minimum clearance to combustibles given on the instruction plate. Wood framing around a heater is a hazard and should not be used.

## 3 SUPPLYING LIQUID PROPANE TO HEATER

This problem has occurred from time to time. To minimize the damage, shut off the gas supply and let the heater run until all of the liquid in the lines has been burnt.

# Preventive Maintenance

Sure Flame Construction Heaters are built to withstand the rigours of operating on construction sites, mining applications, and a multitude of other locations where heaters are used. To maintain the reliable performance it is necessary to perform regular maintenance.

## A VISUAL CHECKS

The following items should be checked for excessive wear or damage:

- 1) Wheels
- 2) Cords and Connectors
- 3) Wiring and Conduit
- 4) Heater Shell (including heat shield) and Control Box

## B BURNER

Flame Rod and Insulator - Clean with soap and water or solvent on a routine basis. Any build up on burner should also be removed at this time.

Ground Wire - Ensure that the ground wire is secured to the burner. This is necessary for the flame detection system to operate.

Spark Plug - Clean with solvent and check spark gap.

## C FLAME SAFEGUARD CONTROL

The Fenwall Control can be cleaned using compressed air or alcohol. Do not use any other liquid or aerosol spray cleaners.

In areas of high humidity, the control should be removed and placed in a dry atmosphere when the heater is expected to be out of service for an extended time.

It is recommended that units purchased as spares be rotated periodically, so that each unit will be placed in operation at least once every 90 days.

D MOTOR - Motors equipped with oil cups should require only a few drops of clean, light machine oil every year. Motors not equipped with oil cups are fitted with sealed bearings and no oiling is required.

E FAN - Check for dust or dirt build up on fan blades. Check the tightness of the set screw and run the heater to check for fan vibration.

# Troubleshooting

The troubleshooting section has been divided in to six tables. Choose the appropriate table from the list below:

Chart A – Heater does not start, fan does not start

Chart B – Heater does not start, fan starts, no spark, no flame

Chart C – Heater does not start, fan starts, spark, no flame

Chart D – Heater starts, flame lights but goes out after a few seconds

Chart E – Heater starts, but fails during operation

Chart F – Other problems

### Chart A – Heater does not start, fan does not start

Symptom	Possible Causes	Indicators Outside Control Box						Indicators Inside Control Box					
		Green Start Switch	Red Stop Switch	Thermostat Power Light	Thermostat Stage 1 Light	Thermostat Stage 2 Light	L2	L6	L7	L8	L12	Flame Control LED	
Green start light does not come on when start switch is pressed.	No electrical supply	off	off	off	off	off	off	off	off	off	off	off	off
	Stop switch fails open	off	off	off	off	off	on	off	off	off	off	off	off
	Start switch fails open												
Green start light comes on when pressed, but goes off when released. L12 flashes when start switch released.	Fuse failure	on/ off	off	off	off	off	on	off	off	off	off	*	Off
	Reset switch fails open	on	off	off	off	off	on	off	off	off	off	off	Off
Green start light is on, but red stop light remains off during attempts to start.	Thermostat stage 1 fails open	on	off	-	-	-	on	off	off	off	off	off	off
	Flame control failure – Power in	on	off	on	-	-	on	off	off	off	off	off	off
	Flame control failure – Thermostat in	on	off	on	on	-	on	off	off	off	off	off	off
	Flame control failure – Motor out	on	on	on	on	-	on	off	off	off	off	off	*
Green start light is on, red stop light comes on during attempts to start	Motor relay fails open	on	on	on	on	-	on	on	off	off	off	off	*
	Motor failure	on	on	on	on	-	on	on	off	off	off	off	*
	Low Voltage (long extension cord or too many items on circuit). Motor relay may chatter.	on	on	on	on	-	on	*	*	off	off	off	off
Air switch fails closed	on	on	on	-	-	on	off	off	off	off	off	*	

**Chart B – Heater does not start, fan starts, no spark, no flame**

Symptom	Possible Causes	Indicators Outside Control Box						Indicators Inside Control Box				
		Green Start Switch	Red Stop Switch	Thermostat Power Light	Thermostat Stage 1 Light	Thermostat Stage 2 Light	L2	L6	L7	L8	L12	Flame Control LED
Air blowing through heater in reverse.	Motor wired incorrectly	on	on	on	-	on	on	on	off	off	off	*
No gas odor at heater outlet. L7 light is off. Voltage between N2 and L15 is 120V during attempt to start.	Air tubes set in wrong position Air switch fails open Air switch set to too high a pressure Air tubes plugged	on	on	on	-	on	on	off	off	off	*	
No gas odor at heater outlet. L7 light is off. Voltage between N2 and L15 is 0V during attempt to start.	Strainer plugged or dirty Gas pressure switch fails open Too small of a hose, too long of a hose, blocked hose Too low of inlet pressure Second stage regulator set too low Propane tank too small to vapourize fast enough, tank freezes Upstream regulators installed backwards Flame control failure – Air in	on	on	on	-	on	on	off	off	off	*	
No gas odor at heater outlet. L7 light is on.	Flame control failure – spark out	on	on	on	-	on	on	on	off	off	*	
Gas odor at heater outlet. L7 light on. L8 light on, then off.	Spark plug fails Flame rod and spark plug wires reversed Spark plug wire damaged	on	on	on	-	on	on	on	on/off	off	***	

**Chart C – Heater does not start, fan starts, spark, no flame**

Symptom	Possible Causes	Indicators Outside Control Box						Indicators Inside Control Box				
		Green Start Switch	Red Stop Switch	Thermostat Power Light	Thermostat Stage 1 Light	Thermostat Stage 2 Light	L2	L6	L7	L8	L12	Flame Control LED
No gas odor at heater outlet. L8 light is off. Voltage between N2 and L17 is 120V during attempt to start.	Limit switch fails open	on	on	on	on	-	on	on	on	off	off	***
		on	on	on	on	-	on	on	on	off	off	***
No gas odor at heater outlet. L8 light is off. Voltage between V1 and V2 on flame controller is 0V during attempt to start.	Flame control failure	on	on	on	on	-	on	on	on	on/off	off	***
		on	on	on	on	-	on	on	on	on/off	off	***
No gas odor at heater outlet. L8 light is on, then off.	Manual valve closed	on	on	on	on	-	on	on	on	on	on	***
	Solenoid valve fails closed	on	on	on	on	-	on	on	on	on	on	***
	Too high of inlet pressure. Second stage regulator set too high. (This may cause the 2-stage regulator to be damaged)	on	on	on	on	-	on	on	on	on	on	***
	Gas pressure switch failed closed and inlet pressure low	on	on	on	on	-	on	on	on	on	on	***
	2-stage regulator installed backwards	on	on	on	on	-	on	on	on	on	on	***
Gas odor at heater outlet. L8 light on, then off.	Burner orifices plugged or dirty	on	on	on	on	-	on	on	on	on	on	***
	Spark plug gap too large (weak spark) or too small. Gap should be set to 1/8 inch.	on	on	on	on	-	on	on	on	on	on	***
	Low flame regulator setting too low	on	on	on	on	-	on	on	on	on	on	***

**Chart D – Heater starts, flame lights but goes out after a few seconds**

Symptom	Possible Causes	Indicators Outside Control Box						Indicators Inside Control Box				
		Green Start Switch	Red Stop Switch	Thermostat Power Light	Thermostat Stage 1 Light	Thermostat Stage 2 Light	L2	L6	L7	L8	L12	Flame Control LED
Connect DC current meter with microampere range to terminals FC+ and FC- of the flame controller. Start heater. Check reading once flame is established. Reading is 1.0 microamperes or higher	Flame control failure – Flame sensing	on	on	on	on	-	on	on	on	on/off	off	***
		on	on	on	on	-	on	on	on	on/off	off	***
		on	on	on	on	-	on	on	on	on/off	off	***
Reading from above is less than 1.0 microamperes.	Flame rod dirty, cracked, or otherwise defective. Flame rod wire loose or damaged Burner not grounded											



**Chart E – Heater starts, but fails during operation**

Symptom	Possible Causes	Indicators Outside Control Box						Indicators Inside Control Box				
		Green Start Switch	Red Stop Switch	Thermostat Power Light	Thermostat Stage 1 Light	Thermostat Stage 2 Light	L2	L6	L7	L8	L12	Flame Control LED
Normal flame length prior to failure. Three flashes on flame control LED.	Low Voltage (long extension cord or too many items on circuit)	on	on/off	on	on	-	on	on/off	on/off	off	off	***
		on	on	on	on	-	on	on	on/off	off	off	*
Smaller than normal flame prior to failure. Single flash on flame control LED.	Propane tank too small to vaporize fast enough, tank freezes	on	on	on	on	-	on	on	on/off	off	off	***
Normal flame length prior to failure. Three flashes on flame control LED. Immediately after failure, voltage between N2 and L17 is 120V, between N2 and L16 is 0V.	Strainer plugged or dirty	on	on	on	on	-	on	on	on/off	off	off	***
		on	on	on	on	-	on	on	on/off	off	off	***
Longer than normal flame before failure, possibly shooting outside of heater body. Three flashes on flame control LED. Immediately after failure, voltage between N2 and L17 is 120V, between N2 and L16 is 0V.	Limit switch failure – too sensitive	on	on	on	on	-	on	on	on/off	off	off	***
	Changeover valve set to natural gas when connected to propane.	on	on	on	on	-	on	on	on/off	off	off	***
	Connected to liquid propane	on	on	on	on	-	on	on	on/off	off	off	***
	Too high of inlet pressure	on	on	on	on	-	on	on	on/off	off	off	***
Second stage regulator set too high	Second stage regulator set too high	on	on	on	on	-	on	on	on/off	off	off	***
	High flame regulator setting too high	on	on	on	on	-	on	on	on/off	off	off	***

**Chart F – Other Problems**

Symptom	Possible Causes	Indicators Outside Control Box						Indicators Inside Control Box							
		Green Start Switch	Red Stop Switch	Thermostat Power Light	Thermostat Stage 1 Light	Thermostat Stage 2 Light	L2	L6	L7	L8	L12	Flame Control LED			
Excessive vibration or noisy operation.	Damaged or unbalanced fan blade	on	off	on	on	-	on	on	on	off	on	on	off	off	off
Fan motor starts immediately when heater is plugged in, even if thermostat is not calling for heat	Motor relay fails closed	off	off	off	off	off	on	off	off	off	on	off	off	off	off
Heater will start as soon as it is plugged in. Stop button will reset the heater.	Start switch fails closed	on	off	on	-	-	on	-	-	-	on	-	-	-	-
Flame length shorter than normal	Low flame regulator setting too low	on	off	on	on	-	on	on	on	off	on	on	off	off	off
Normal operation except flame length shorter than normal	High flame regulator setting too low	on	off	on	on	on	on	on	on	off	on	on	off	off	off
Small flame, otherwise functions normally.	Changeover valve set to propane when connected to natural gas	on	off	on	on	-	on	on	on	off	on	on	off	off	off
Heater will never go to high flame.	Thermostat stage 2 fails open	on	off	on	-	-	on	on	on	off	on	on	off	off	off
Normal operation, but low flame longer than normal.	Low flame regulator setting too high	on	off	on	on	-	on	on	on	off	on	on	off	off	off
Gas will flow to burner immediately when supply to heater is opened	Solenoid valve fails open	-	-	-	-	-	-	-	-	-	-	-	-	-	-
Gas will flow to burner immediately when supply to heater is opened	Solenoid valve leaks	-	-	-	-	-	-	-	-	-	-	-	-	-	-

Gas will flow to burner immediately when supply to heater is opened	Solenoid valve installed backwards	-	-	-	-	-	-	-	-	-	-	-	-	-	-	-	-	-	-	-	
Heater lights but uneven flame.	Burner orifices plugged or dirty	on	off	on	on	on	on	on	on	on	on	on	on	on	on	on	on	on	on	on	off
Heater will always stay on (either high or low) regardless of ambient temperature	Thermostat stage 1 fails closed	on	off	on	on	on	on	on	on	on	on	on	on	on	on	on	on	on	on	on	off
Heater will switch between off and high, but never low flame	Thermostat stage 2 fails closed	on	off	on	on	on	on	on	on	on	on	on	on	on	on	on	on	on	on	on	off
Heater will function normally, but if it shuts down, it will not start up again without pressing the stop switch	Reset switch fails closed	on	off	on	on	on	on	on	on	on	on	on	on	on	on	on	on	on	on	on	off
Heater will function normally, but red light does not come on during startup sequence	Flame control failure – NC light out	on	off	on	on	on	on	on	on	on	on	on	on	on	on	on	on	on	on	on	off
Heater will start normally but will not stop when the stop switch is pressed	Stop switch fails closed	on	off	on	on	on	on	on	on	on	on	on	on	on	on	on	on	on	on	on	off
During operation, flame goes out for a few seconds, then relights. Stage 1 thermostat light remains on during this time.	Air switch set to too high a pressure	on	off	on	on	on	on	on	on	on	on	on	on	on	on	on	on	on	on	on	off
Heater will continue operating when the air flow is obstructed with longer than normal flames. Limit switch may cause heater to shut down.	Air switch set to too low a pressure	on	off	on	on	on	on	on	on	on	on	on	on	on	on	on	on	on	on	on	off
Heater will start normally, but will not shut down in an overheat situation	Limit switch fails closed	on	off	on	on	on	on	on	on	on	on	on	on	on	on	on	on	on	on	on	off

# Replac

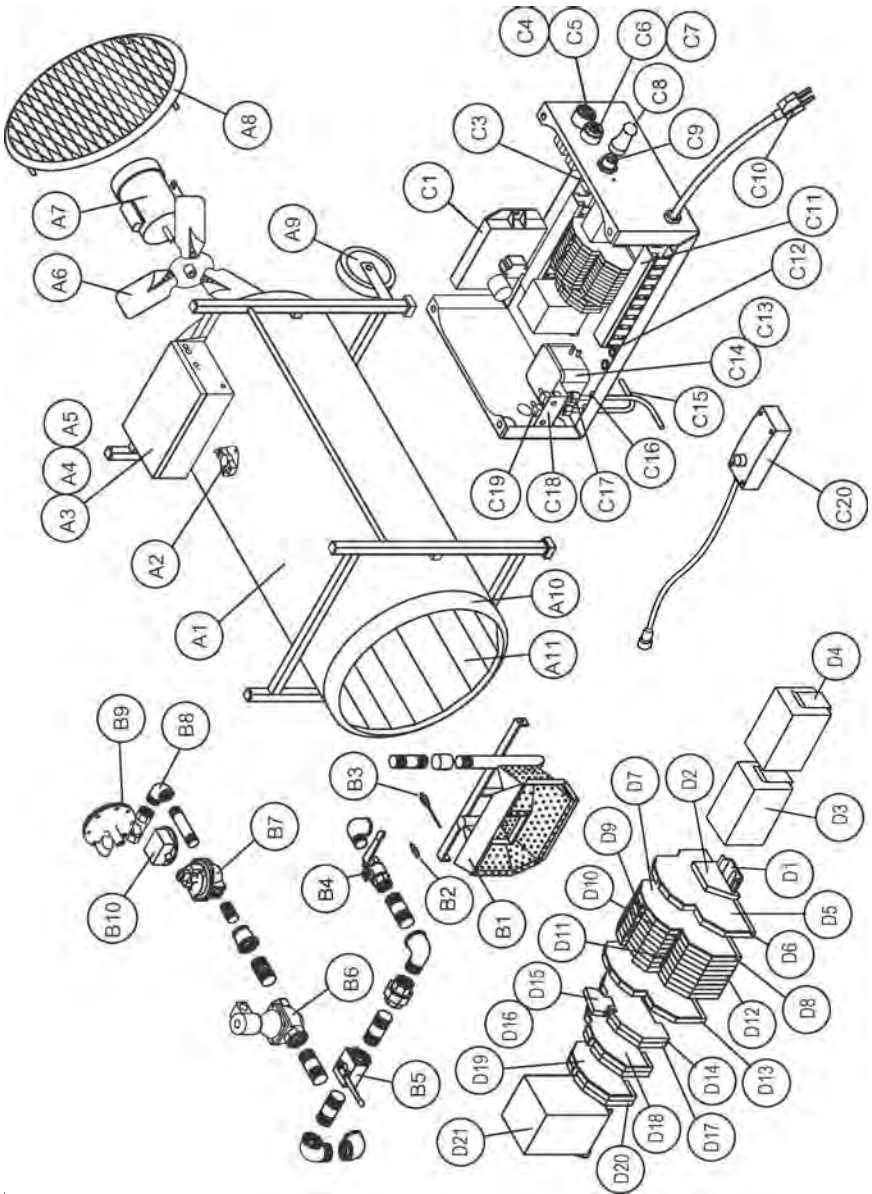

Ref	Part No.	Description	Ref	Part No.	Description
A1	S1505-56	Heater Body (includes A10 & A11)	C11	S1500-107	Wiring Duct, 7"
A2	2446	Limit Switch, 180°F	C12	5509	Snap Bushing, 1/2"
A3	S1500-104	Control Box Lid	C13	S1500-710	Adjusted Air Switch
A4	S1500-501	Control Box	C14	9294	Vinyl Tube, 3/16"
A5	7723	Control box Seal	C15	S1500-109	Air Tube
A6	2423	Fan Blade, 24"	C16	5515	Rubber Grommet
A7	9262	Motor, 1HP	C17	2554	Compression Fitting, 1/4" Tubex1/8" MNPT
A8	SL11B-53	Screen	C18	S1500-502	Air Tube Bracket
A9	6119	Wheel	C19	9348	Connector, 1/8" MNPT x .170" HB 90° Elbow
A10	SL11B-13	Nose Cone	C20	S1500-716	Remote Thermostat Assembly w/Cable
A11	SL11B-90	Heat Shield			
B1	BV85-50	Burner	D1	S1500-105	Mounting Rail
B2	2143	Spark Plug	D2	9443	Ground Terminal Block (WK 4SL/U) green/yellow
B3	SL11B-86	Flame Rod	D3	9264	Power Relay, 120V
B4	2539	Manual Shut-Off Valve, 1-1/2"	D4	9826	Relay Clip
B5	S1505-81	Gas Selector Valve, 1-1/2"	D5	9280	End Plate (APC 1-2.5 D2/E), Green
B6	2537	Solenoid Valve, 1-1/2"	D6	9275	Terminal Block (WKC 2.5 D2/2 SL35), Green
B7	4490	2-Stage Regulator, 1-1/4"	D7	9279	End Plate (APC 1-2.5 D2/E), Gray
B8	S1500-86	Strainer Assembly, 1-1/4"	D8	9277	Terminal Block (WKC 2.5 E/35), Red
B9	2528	Regulator (optional)	D9	9283	Cross Connector, 2 Pole
B10	4509	Gas Pressure Switch	D10	9284	Cross Connector, 3 Pole
			D11	9285	Cross Connector, 5 pole
C1	9624	Flame Controller	D12	9276	Terminal Block (WKC 2.5 E), Gray
C3	S1500-108	Wiring Duct, 3"	D13	9274	Terminal Block (WKC 2.5 D2/2 SL35), Gray
C4	9612	Start Button Assembly	D14	9278	Terminal Block (WKC 2.5 TKG/35), Gray
C5	S1500-718	Start Contact Block Assembly	D15	9271	Fuse Holder
C6	9611	Stop Button Assembly	D16	9270	Fuse, 2A
C7	S1500-717	Stop Contact Block Assembly	D17	9273	Terminal Block (WKC 2.5 D1/2/35), Gray
C8	S1500-713	Thermostat Jumper Assembly	D18	9281	End Plate (APC 1-2.5 D1/TK), Gray
C9	8682	Thermostat Receptacle	D19	9282	End Plate (APC 1-2.5), Gray
C10	3868	Power Cord, 24"	D20	9272	Terminal Block (WKC 2.5/35), Gray
			D21	8659	Utility Box

# S1505B Connection Wiring Diagram

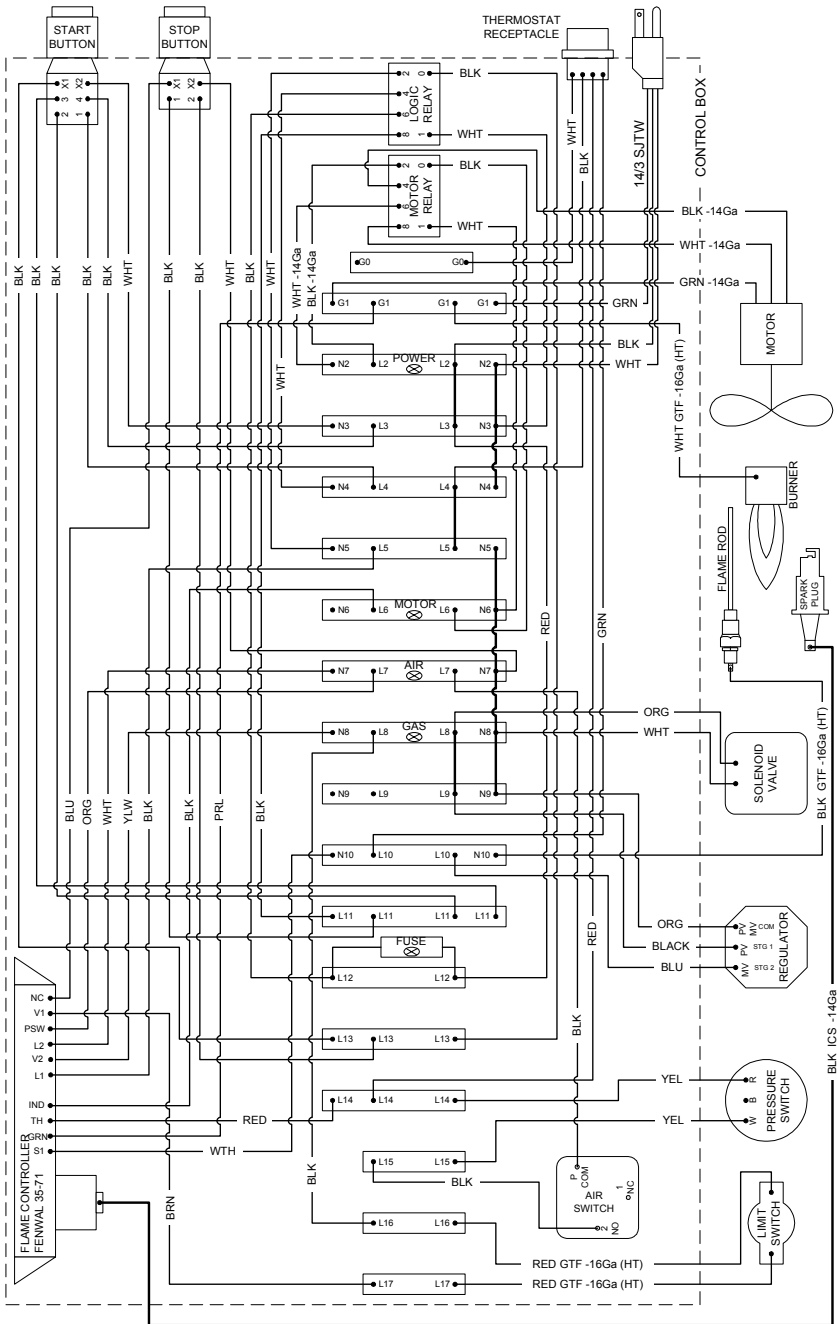

Note: All wires 18 Ga STR TEW 600V unless otherwise specified.

Rev 2.21 From S/N 3960

# Ladder Wiring Diagram

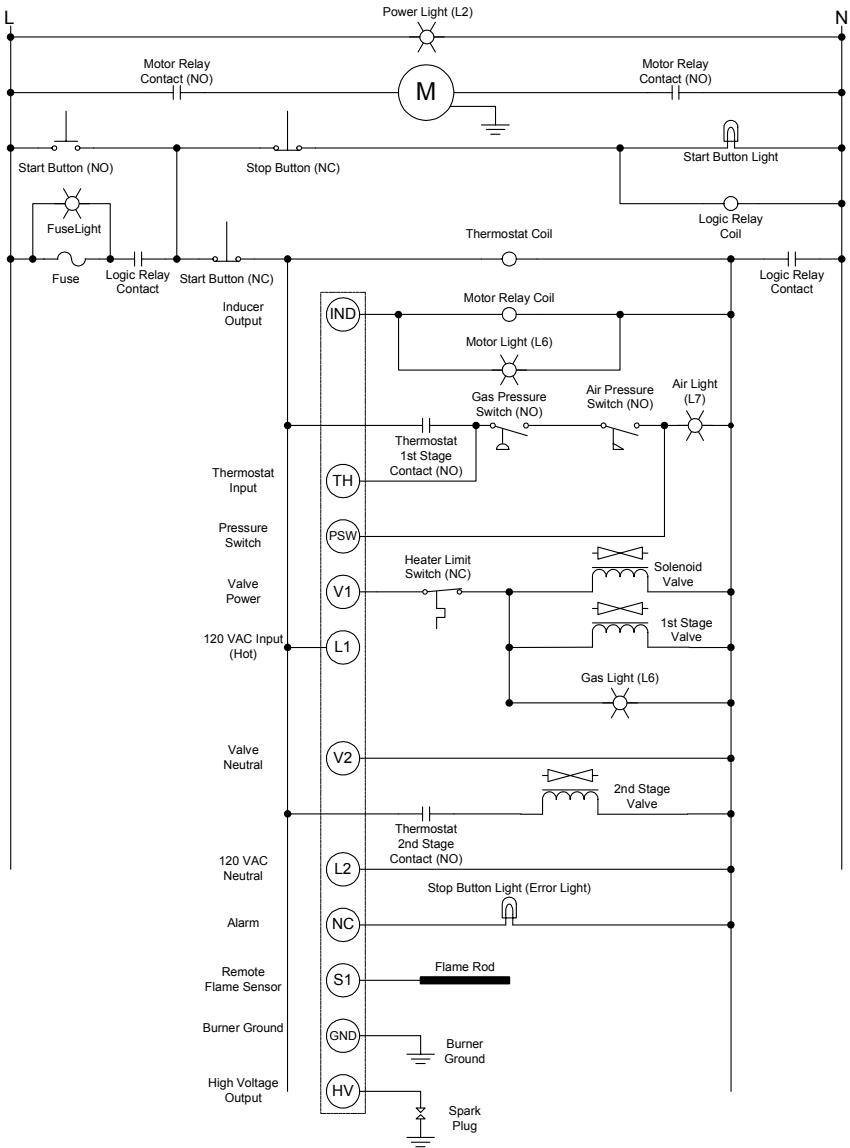

# Two Stage Thermostat Wiring Diagram (S1500-716)

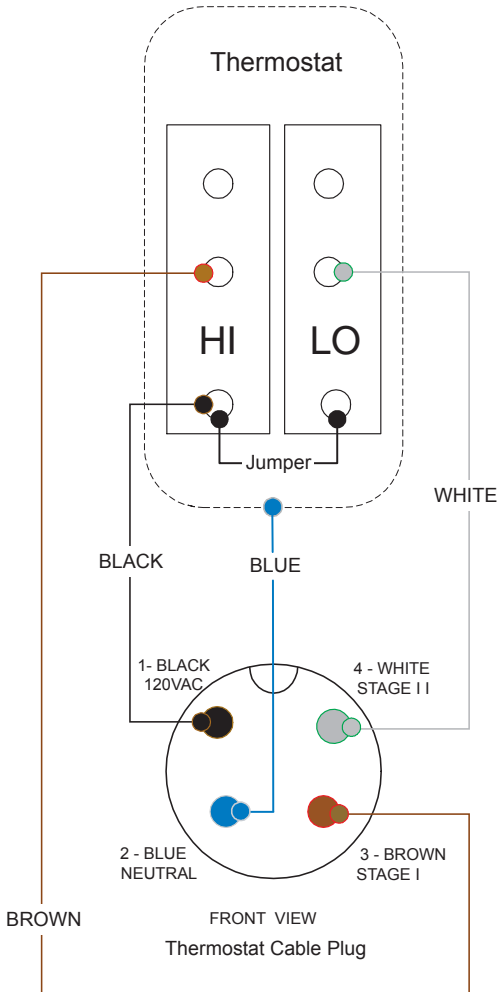



# LPG - PROPANE FUEL

## VAPORIZATION RATE

The following chart shows the amount of BTU's that various sizes of tanks will produce on the average at specific temperatures and regular atmospheric conditions.

Tank Size Gallons (Pounds)	Maximum intermittent withdrawal rate (BTU/hr) without tank frosting* if lowest outdoor temperature (average for 24 hours) reaches.							
	+40 F.	+30 F.	+20 F.	+10 F.	0 F.	-10 F.	-20 F.	-30 F.
150 (600)	214,900	187,900	161,800	148,000	134,700	132,400	108,800	107,100
250 (1000)	288,100	251,800	216,800	198,400	180,600	177,400	145,800	143,500
500 (2000)	478,800	418,600	360,400	329,700	300,100	294,800	242,300	238,600
1000 (4000)	852,800	745,600	641,900	587,200	534,500	525,400	431,600	425,000

\* Frosting on the outside of the tank acts as an insulator, reducing the vaporization rate.

## MAXIMUM BTU CONTENT (PROPANE)

The following table shows the maximum BTU's that a cylinder contains.

CYLINDER SIZE	BTU CONTENT
100 pound	2,159,100
250 gallon USA	22,922,500
500 gallon USA	45,845,000
1000 gallon USA	91,690,000

**CAUTION:** In extremely cold weather it is impossible to completely empty a propane cylinder.

## PRESSURE & FLOW EQUIVALENTS

1 Std. Atmosphere =	14.73 lb./sq. in. =	1.014 bar
1" Water Column (W.C.) =	0.58 oz./sq. in. =	2.49 millibar
11" Water Column =	0.4 lb./sq. in.=	27.39 millibar
1 lb./sq. in. (psig) =	27.71" W.C. =	0.0689 bar
1" Mercury =	0.49 psig =	33.86 millibar
1 Std. Cubic Ft./Hr. =	2,500 BTU/Hr. =	0.02832 cu. m/hr.
1 BTU/Hr. =	0.2931 Watts	

# NOTES:

# NOTES: