



*Hunter*  
INDUSTRIAL

TITAN

INSTALLATION MANUAL

## CONTENTS



### BEFORE YOU BEGIN

SAFETY & PRECAUTIONS	2-3
FAN PLACEMENT	4
MAINTENANCE	5
IN THE BOX	6
TOOLS NEEDED	7



### INSTALLATION

STEP 1: MOUNTING	8
STEP 2: MOTOR ASSEMBLY	9
STEP 3: RETENTION SYSTEM	10
STEP 4: CONTROL PANEL	11
STEP 5: TOUCHSCREEN	12
STEP 6: GUY WIRES	13
STEP 7: BLADES	14



### TOUCHSCREEN

TOUCHSCREEN TYPES	15-16
HOME SCREEN	17
FAN SCREEN	18



### REFERENCE

ELECTRICAL	19
TOUCHSCREEN TEMPLATE	20
CONTROL PANEL	21
TROUBLESHOOTING	22



1886

## LEGACY

The Hunter legacy is not only about quality—it's about longevity. We invented the ceiling fan. We build fans that last, fans that are designed as fans. We design our fans while considering each person in the process—from the installer to the owner.

## AUTHENTICITY

In a world full of impersonators, be an original. We invented the ceiling fan, and we stand behind our products.

*Hunter*  
INDUSTRIAL



## BEFORE YOU BEGIN

# SAFETY & PRECAUTIONS

## READ THE ENTIRE MANUAL BEFORE OPERATING THE FAN

Read and understand this manual before installing or operating a fan unit. Installation, adjustment, repair or maintenance must be performed by qualified personnel.

Follow all safety practices and instructions during the installation, operation and servicing of the fan. Failure to apply these safety practices could result in death or serious injury. If you do not understand the instructions, please call our Technical Department for guidance. Technical Department contact information can be found on page 22.

All fan controls and incoming power should be installed only by qualified technicians familiar with the requirements of the National Electrical Code and local codes. Failure to follow these guidelines will void the manufacturer's warranty. All electrical controls are configured at the factory and are ready to use. No user adjustments are available. Follow the included installation instructions when installing this device to ensure proper operation. Do not make any changes to any part of the fan without first consulting Hunter Industrial Fan. Installation is to be in accordance with the National Electrical Code, ANSI/NFPA 70-1999 and local codes.



### WARNING!

Be aware of electric shock hazard, explosion, or arc flash

The user is responsible for compliance with all international and National Electrical Code requirements with respect to grounding of all equipment. Many of the parts of this unit operate at line voltage. **DO NOT TOUCH.** Install all covers before applying power or starting and stopping the unit. To reduce the risk of electric shock or injury, use this unit only in the manner intended by the manufacturer. If you have questions, call our Technical Department at 1-844-593-FANS (3267).

Before servicing or cleaning the unit, switch power off at the service panel and lock the service disconnecting means to prevent power from being switched on accidentally. When the service disconnecting means cannot be locked, securely fasten a prominent warning sign, such as a tag, to the service panel. At all times, leave the power off at the service panel. To reduce the risk of electric shock or injury, use this unit only in the manner intended by the manufacturer. If you have questions, call our Technical Department at 1-844-593-FANS (3267).

## DAMAGED EQUIPMENT

Do not operate or install any fans or fan accessories that appear to be damaged. Failure to follow this instruction can result in death, serious injury, or equipment damage.

## SERVICE

If the fan does not operate properly using the procedures in this manual, remove all power to the unit and contact our Technical Department for further assistance at 1-844-593-FANS (3267). **Keep all body parts clear of moving parts at all times. All electrical troubleshooting and repair must be done by a qualified technician and meet all applicable codes.**



## BEFORE YOU BEGIN

# SAFETY & PRECAUTIONS

## KEY RETENTION SYSTEM COMPONENTS

Our fans are engineered with key features to prevent pieces of the fan from falling in the unlikely event of a catastrophic failure. Used together, these systems provide comprehensive protection of people, equipment and property.

Install the retention cable on EVERY fan. The retention cable, if installed per Hunter Industrial Fan specifications, will prevent the fan from falling in the unlikely event that the mounting system should fail.

### CAUTION!

The fan should never be run without a properly installed retention cable, which is supplied with every fan along with all required hardware. If the retention cable is not installed, the warranty will be voided.

## MARK THE FLOOR TO ALERT PERSONNEL

When mounting a fan in an area where materials may be elevated into its path, we recommend marking or painting the floor with a large crosshatched circle to alert personnel of the overhead location of fans.

## WEIGHT CONSIDERATIONS

We recommend that a building structure be capable of holding approximately twice the stated hanging weight of the fan.

The maximum hanging weight for the 24-foot fan is 204 lbs., adding the weight of an additional drop length.

If there is any uncertainty in the strength of the building structure, a professional structural engineer should perform a thorough evaluation of the building prior to purchasing the fans. Hunter Fan provides guidelines for mounting fans; however, it is the sole responsibility of the building owner and installer to ensure the safety of the mounting system, that the building structure is sound, and that the installation complies with all federal, state, and local codes.

## CHECK FEDERAL, STATE, AND LOCAL CODES

Check all relevant codes to make sure that all product certifications, product listings, and building regulations are met.

Code compliance is the responsibility of the installer.

## WINDY CONDITIONS

Fans should not be operated in windy conditions. Fans should not be installed in locations where it is frequently windy.



## BEFORE YOU BEGIN

# FAN PLACEMENT

## SPRINKLER SYSTEMS AND FAN PLACEMENT

In any installation where fire sprinklers are in place, the fan should not interfere with their correct operation. Fans should be located no less than 3 feet below a sprinkler, and placed central to each sprinkler quadrant. Our industrial control panel can be connected to a fire relay system, which, in an emergency, will stop fans in case of fire.

Prior to installing fans, review all codes applicable to sprinkler systems and fans to ensure code compliance and refer to NFPA 13 Standard from the National Fire Prevention Association.

Please call our Technical Department for guidance at 1-844-593-FANS (3267). However, it is your sole responsibility to see that the installation is completed to code and that it is correct.

## OTHER INFORMATION ON PLACEMENT AND SPACING

If possible, avoid mounting fans directly below lights or skylights to avoid any strobe effect caused by moving airfoils. Note, a large fan, 20 to 24 feet in diameter, performs best at 20 to 30 feet above the floor, but acceptable performance has been demonstrated as low as 10 feet and as high as 50 feet.

If the building has a mezzanine, fans should be mounted so a person cannot reach a fan in any way from the upper level/deck. Make certain that fans are positioned so that the airfoil tips are at least 3 feet away from any area where a person may be able to extend outward to reach them.

Fans should not be located directly beneath any air discharge. This includes air conditioning units and evaporative coolers. Such equipment can be used effectively in conjunction with HVLS fans but the discharge must be located outside of the swept area of the fan.

## ROOF PITCH

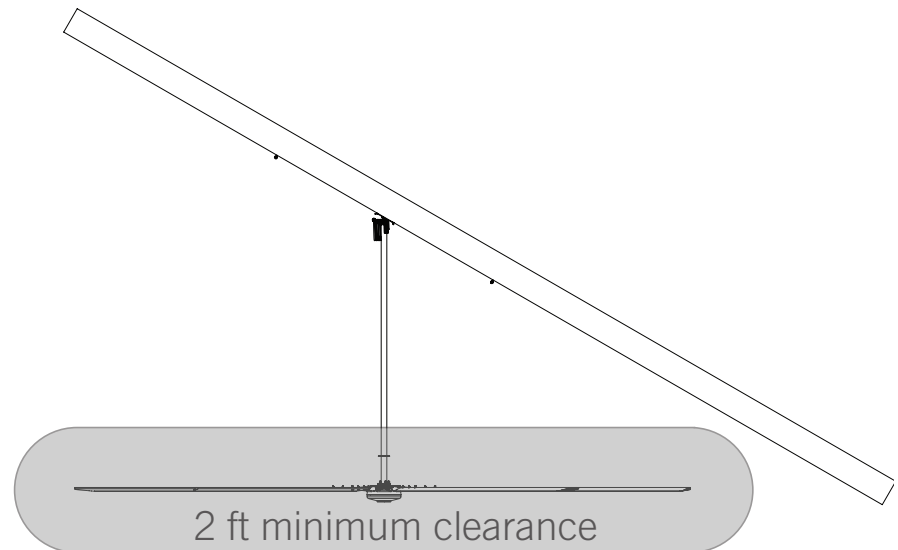



**BEFORE YOU BEGIN**

# MAINTENANCE

---

## GUY WIRE CHECK

Checking a fan's guy wires for tension and inspecting for frayed sections could prevent a problem before it occurs. Fan owners should confirm that the guy wires are not wrapped around any sharp edges. We recommend attaching guy wires to the building with provided clamps to prevent fraying. Turnbuckles should be checked to ensure tightness. If they are loose, the guy wire cables need to be re-tensioned.

## AIRFOIL CLEANING

Depending on the commercial application of the fan, there can be quite a bit of dust or other particulates that cling to the fan's airfoils. While this may not affect fan performance, we recommend fan owners keep airfoils clean by having a maintenance person or skilled trade professional—who has experience using a lift—wipe the fan airfoils with a rag or sponge using hot water or regular cleaning solutions. Please do not use chlorine or any chemicals containing chlorine.

## RETENTION SYSTEM CHECK

Each fan is installed with a retention system. The retention cable is attached to the motor and wraps around the building structure. The safety cable is an important part of the safety system and protects users from if a catastrophic event occurs. It is critical for fan owners to ensure that it is intact and properly secured.

## REPLACEMENT PARTS

Please call our **Technical Department at (844) 593-3267**.



## BEFORE YOU BEGIN

# IN THE BOX

### FAN COMPONENTS

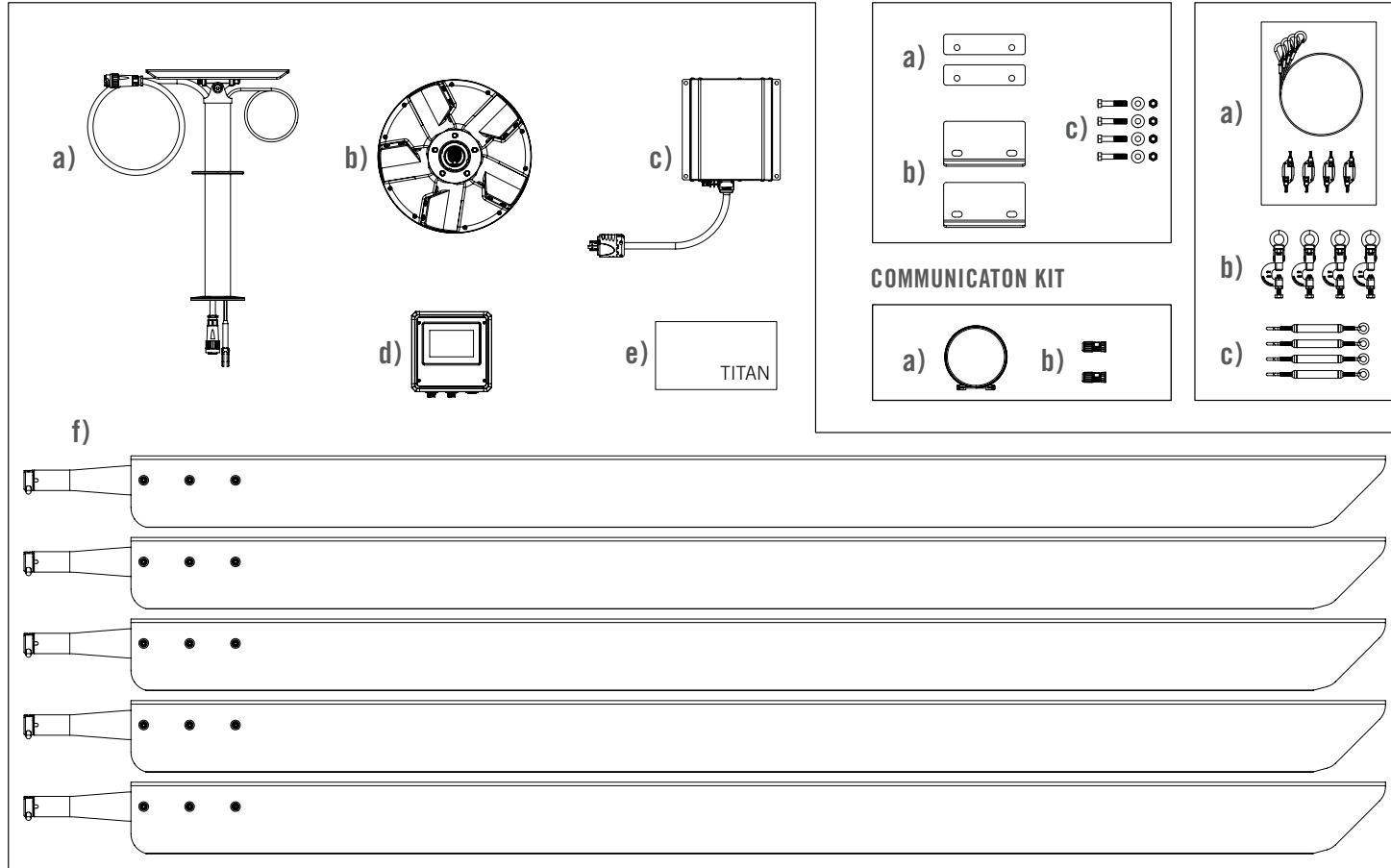

### MOUNTING HARDWARE KIT

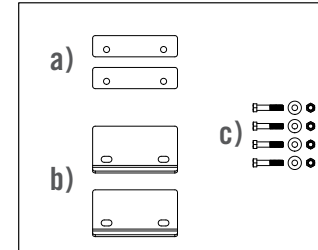

### COMMUNICATION KIT



### GUY WIRE KIT

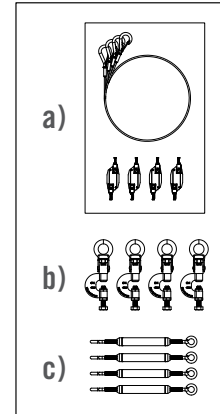

### FAN COMPONENTS

- a) (1) Downrod
- b) (1) Motor & (5) Motor Nuts
- c) (1) ICP (industrial Control Panel)
- d) (1) Touchscreen
- e) (1) Installation Manual
- f) (5) Blades

### MOUNTING HARDWARE KIT

- a) (2) Shims
- b) (2) Clamps
- c) (4) Bolts, Washers, Nuts

### GUY WIRE KIT

- a) (1) Gripper kit
- b) (4) Beam Clamps
- c) (4) Turnbuckles

### COMMUNICATION KIT

- a) (1) 100 ft Terminated Cat5 Cable
- b) (2) RJ45 Connectors



## BEFORE YOU BEGIN

# TOOLS NEEDED

---

- Metric Ratcheting Wrench Set
- Metric (Deep & Short) Socket and Ratchet Set
- Metric Allen Wrench Set
- Metric Allen Socket Set
- Tape Measure
- Magnetic Level
- Torque Wrench
- Wire Rope Cutters
- Phillips and Flat Head Screwdrivers
- #10 to #14 AWG Strippers
- Multimeter
- Cat5 Termination Tools (optional)





## INSTALLATION

# 1 MOUNTING

**A**

Secure bracket and downrod to lift and raise to I-beam.

**B**

Assemble the mount with shims and clamps on bracket. Hook the clamp on one side of the I-beam and tighten hardware until the mount is snug but can still be moved.

**C**

Assemble the opposing shim and clamp on to the I-beam and hand tighten.

**D**

Center the mount under the I-beam. Ensure the clamps have maximum engagement on both sides and tighten hardware.

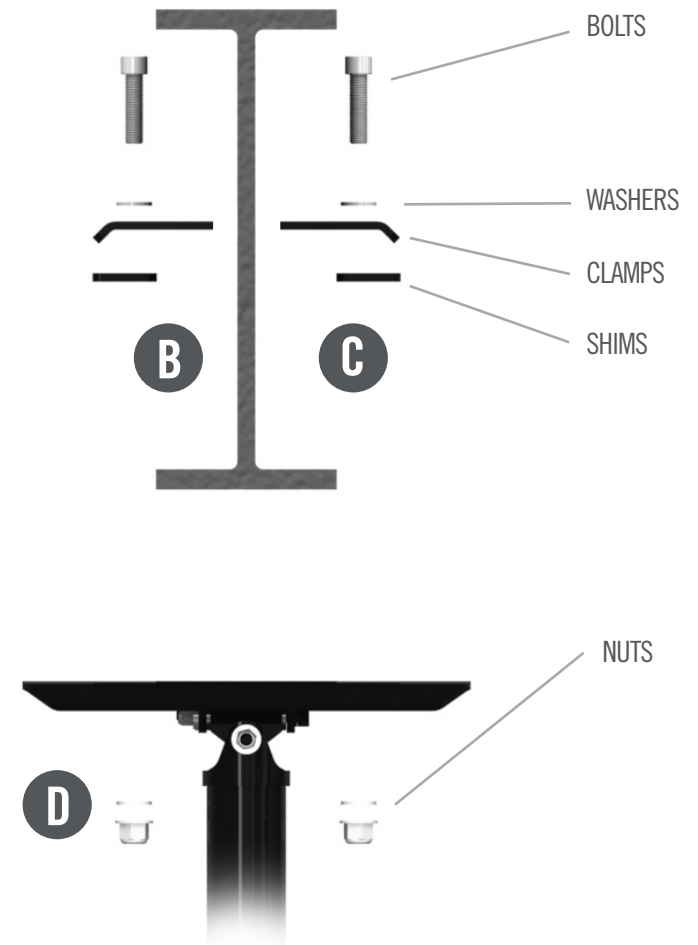



## INSTALLATION

# 2 MOTOR ASSEMBLY

**A**

Insert clevis pin into retention rod and secure with clip provided.

**B**

Join the two connectors and twist, making sure they lock together.

**C**

Lift motor assembly (see tip) while pushing cables into downrod. Feed the press studs through downrod flange. Avoid pinching cable between motor flange and downrod flange and secure with nylon lock nuts. Pull excess wire and cable through top of downrod.

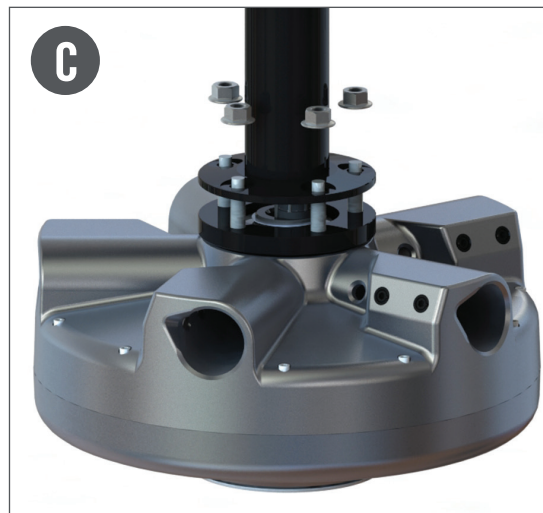
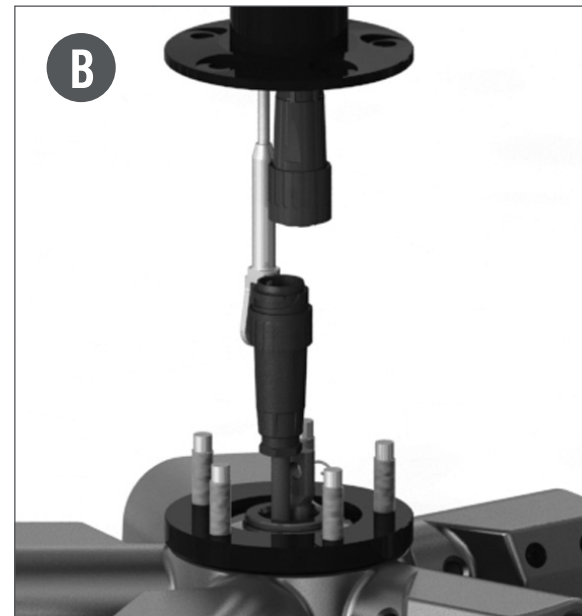

## TIP

*Use packaging to transport motor onto lift equipment. Raise lift to install motor to downrod.*



## INSTALLATION

# 3 RETENTION SYSTEM

**A**

Wrap retention cable around beam or building structure.

**B**

Secure remaining cable to itself with cable clamps. Coil excess cable and secure.

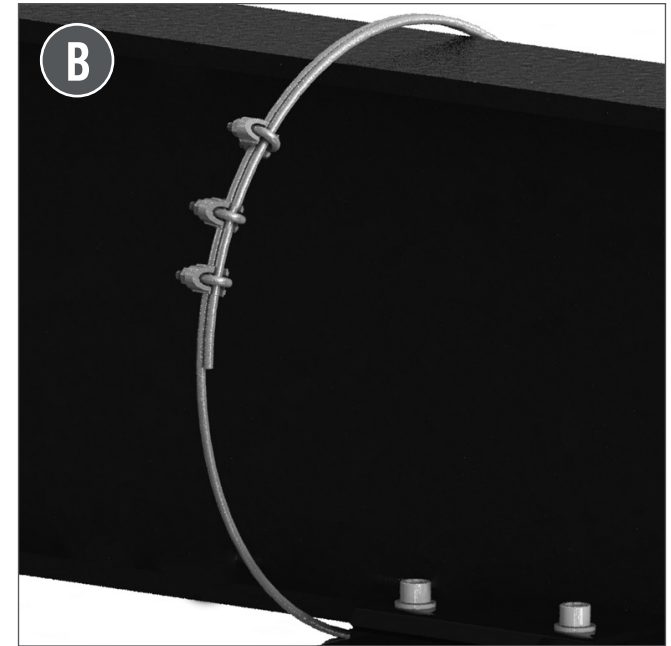



## INSTALLATION

# 4 CONTROL PANEL

### A

Position panel with plug connectors facing down. Mount control panel with fasteners, one in each corner of the panel.

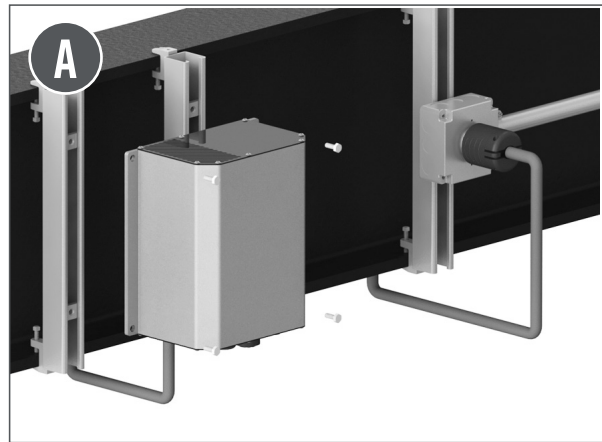

### B

Connect VFD cable from fan to control panel. Twist connector to lock in place. Secure excess cable to ceiling or beam.

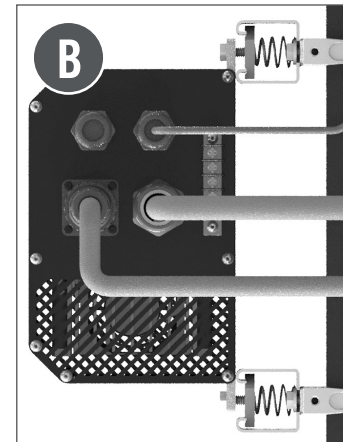

### C

Connect the communication cable to one of the comm terminals and run down to user touchscreen location.

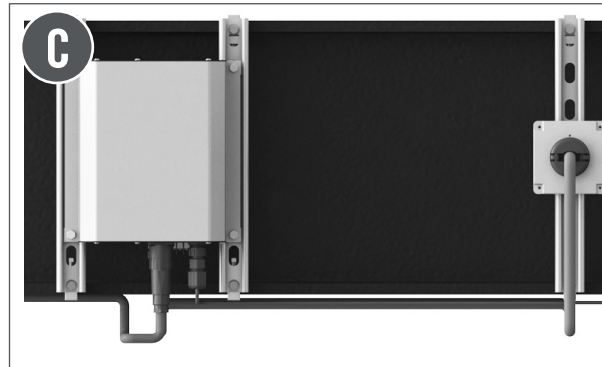

### D

Connect electrical plug to panel. Twist connector to lock into place.

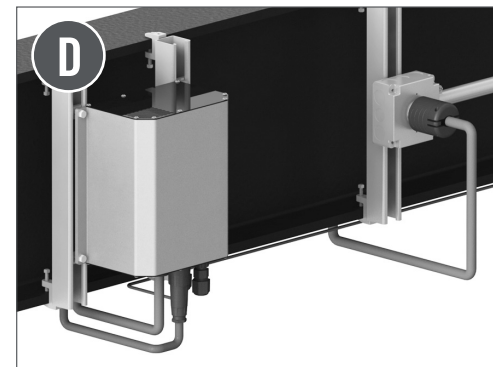

## TIP

*For detailed control panel wiring diagram see Page 21*

## NOTE

*Twist Lock will act as a disconnect.*

**CAUTION: DO NOT CONNECT POWER UNTIL MECHANICAL INSTALLATION IS COMPLETE.**



## WARNING!

Before completing the mechanical installation, ensure breaker is off and all Lockout/Tagout procedures are in place. The electrical receptacle for the panel should be installed prior to panel installation. For a chart of receptacles, refer to page 19.

If the retention cable is not installed, the warranty will be voided.



**A**

Mount touchscreen enclosure to wall.

**B**

Connect communication cable from control panel to the COMM 1 port at base of touchscreen unit.

**C**

Connect pre-wired 110 plug to input power receptacle.

**D**

Attach screen panel to enclosure using screws in each corner.

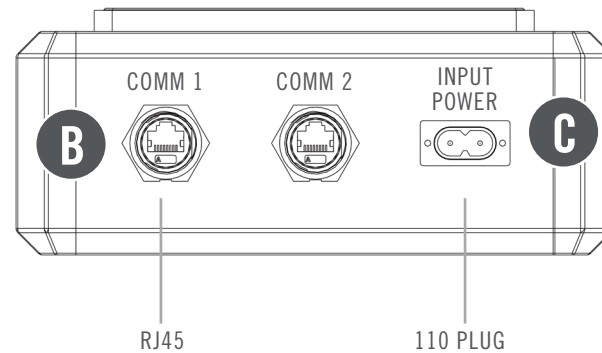
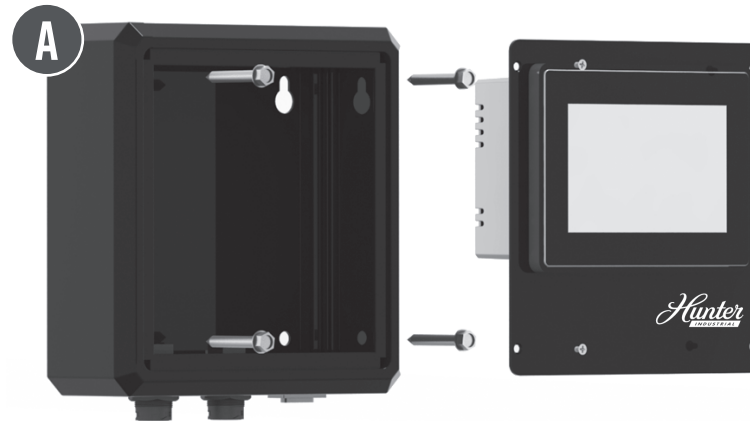

**TIP**

Use Mounting Template on Page 20



**NOTE**

For more information on operating the Touchscreen, refer to Page 15



**A**

Attach guy wire to building structure with provided beam clamps while maintaining a 45-degree angle between the ceiling and the guy wire. DO NOT WRAP GUY WIRES AROUND THE BUILDING STRUCTURE.

**B**

Hook end of turnbuckle to the guy wire disc located on the downrod.

**C**

Attach guy wire to closed turnbuckle end with provided gripper (refer to direction on gripper package).

**D**

Place level against the downrod and tighten the turnbuckles by hand in a crisscross pattern. Periodically check to make sure fan is level. Tighten set screws.

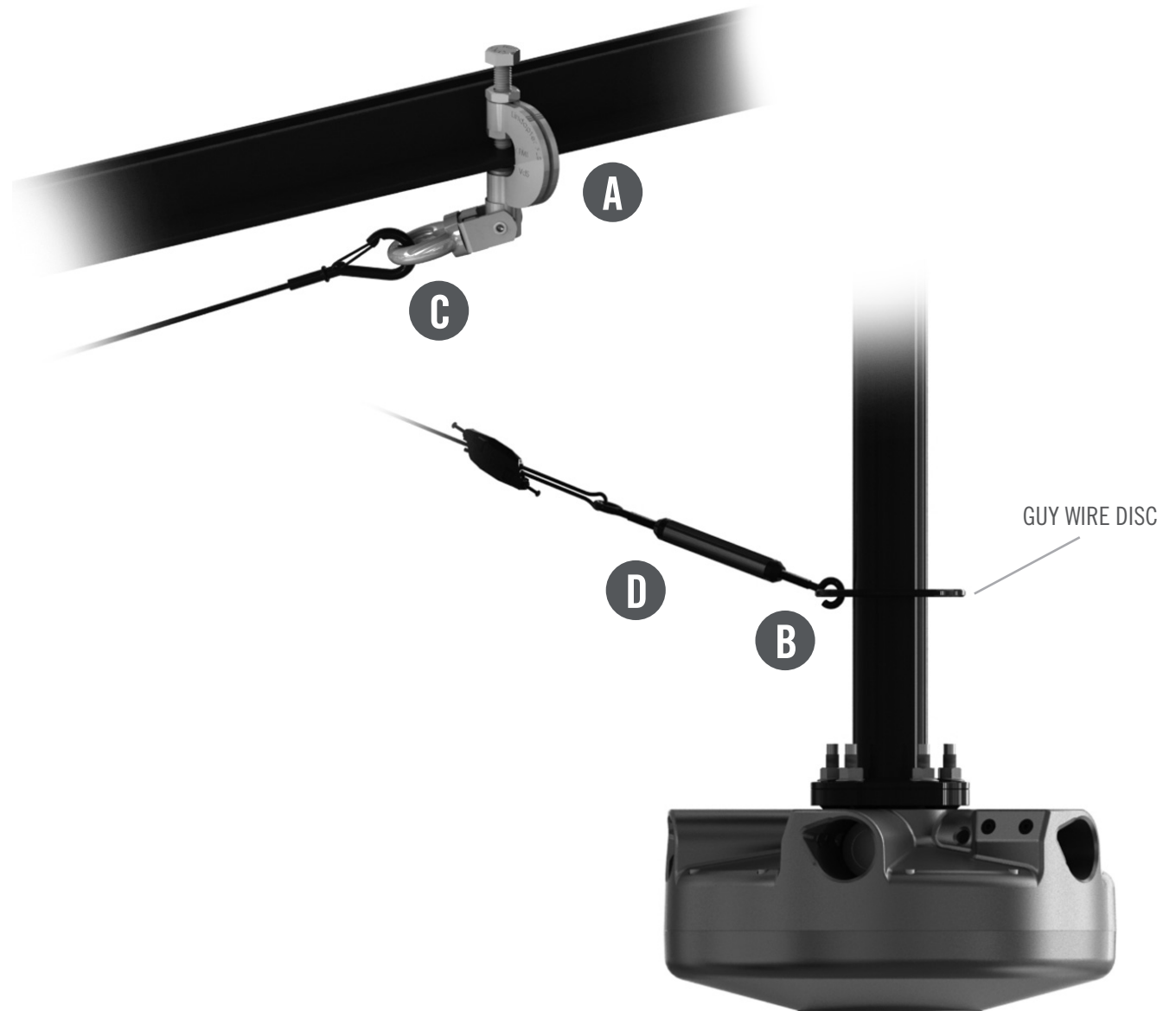



## INSTALLATION

# 7 BLADES

**A**

Line up the pin on the post with the opening on the blade holder.

**B**

Using our quick connect system, insert the blade tube into the blade hub. The blade will click into place at the correct pre-set angle.

**C**

Use a torque wrench to tighten the two set screws to 20 ft. lbs.

(240 lbs.)

**D**

Repeat steps A-C for each of the four remaining blades.

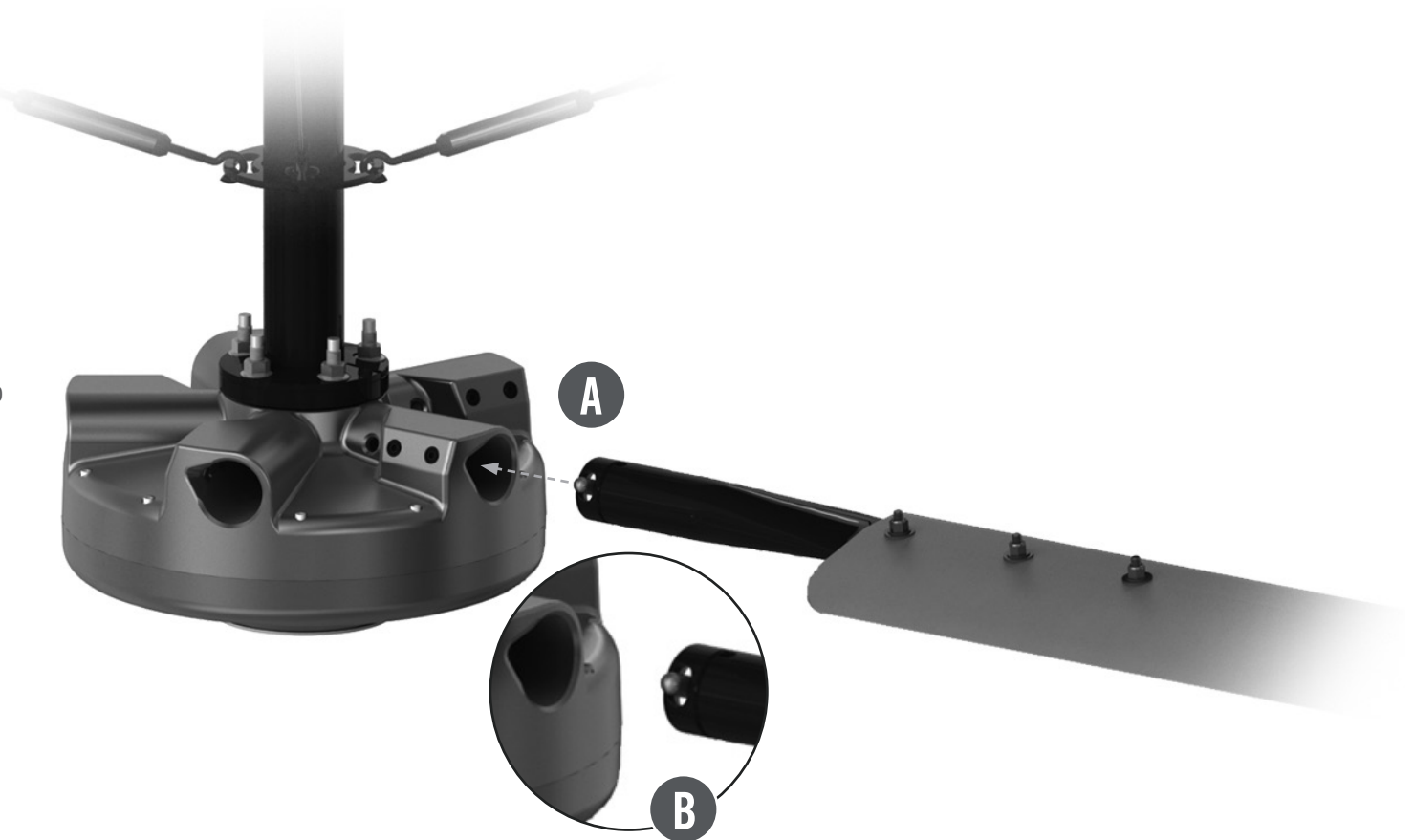



TOUCHSCREEN

# TOUCHSCREEN TYPES

## STARTUP SCREEN



## HOME SCREEN

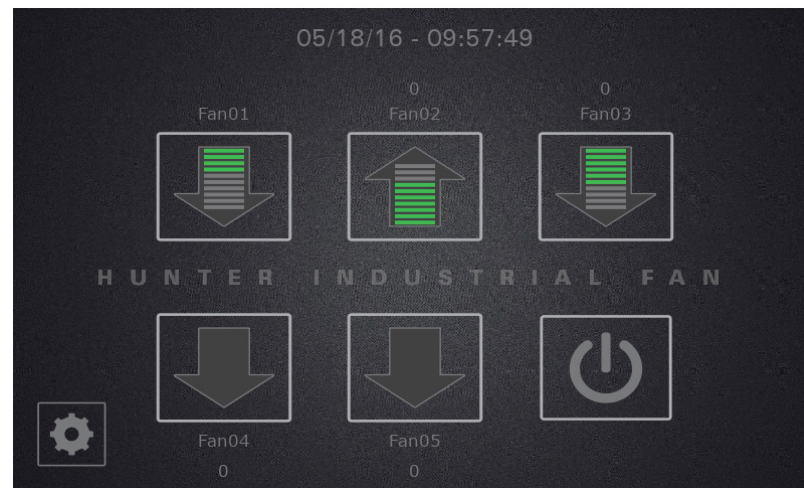





## TOUCHSCREEN

# TOUCHSCREEN TYPES

### FAN SCREEN



### CONFIGURATION SCREEN

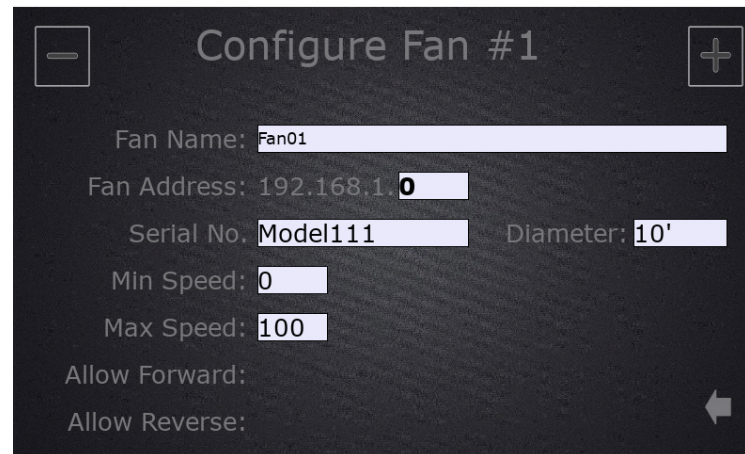



# TOUCHSCREEN

# HOME SCREEN

05/18/16 - 09:57:49

Date and time display



Arrows take you to individual fan screens and display the speed and direction of each fan. Speed is indicated by the lit green bars, while airflow direction is shown by the up or down placement of the arrows.



Powers all fans on and off.

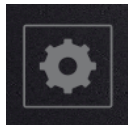

Settings button will take you to the version screen.

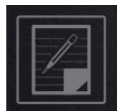

Configure button takes you to individual fan input screens.

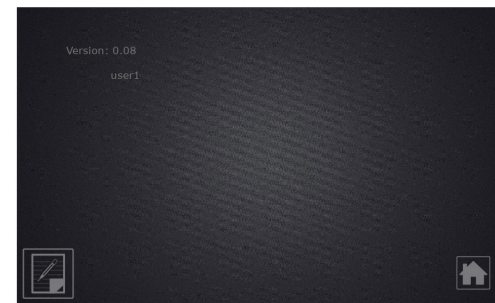

Takes you back to main screen.

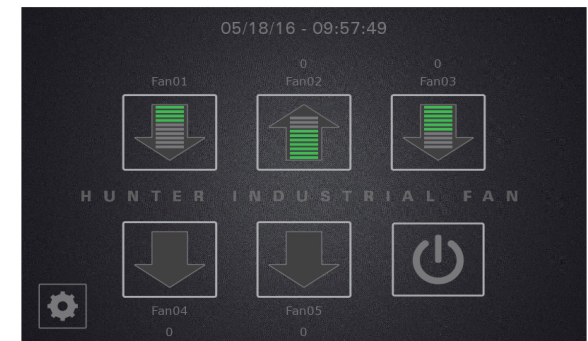
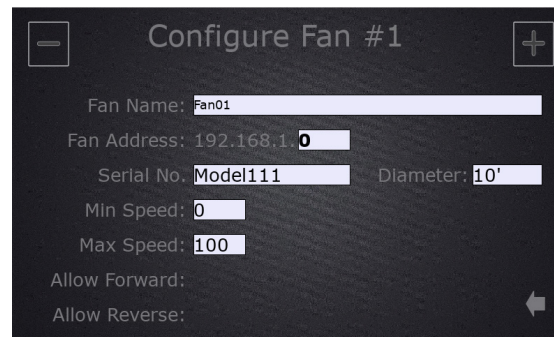



## TOUCHSCREEN

# FAN SCREEN



Press to turn individual fan on or off. When button is green, fan is on. When button is gray, fan is off.



Press to set downward airflow direction.

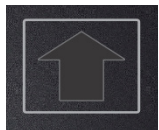

Press to set upward airflow direction.

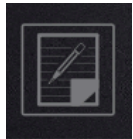

Configure button takes you to the current fan input screen.

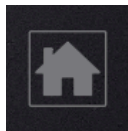

Takes you back to main screen.



Press “+” to increase fan speed, “-” to reduce.

Use “+” and “-” as toggle to configure multiple fans.

Configure Fan #1

Fan Name: Fan01

Fan Address: 192.168.1.0

Serial No. Model111 Diameter: 10'

Min Speed: 0

Max Speed: 100

Allow Forward:

Allow Reverse:

## NOTE

For all buttons, “green” indicates an “ON” status



### Electrical Plug Requirements

Voltage	Phase	Plug (included)	Receptacle
200-240V	Single	HBL2321	L6-20R
200-240V	Three	HBL2421	L15-20R
380-480V	Three	HBL2431	L16-20R

HBL2321



HBL2421



HBL2431





REFERENCE

# TOUCHSCREEN TEMPLATE

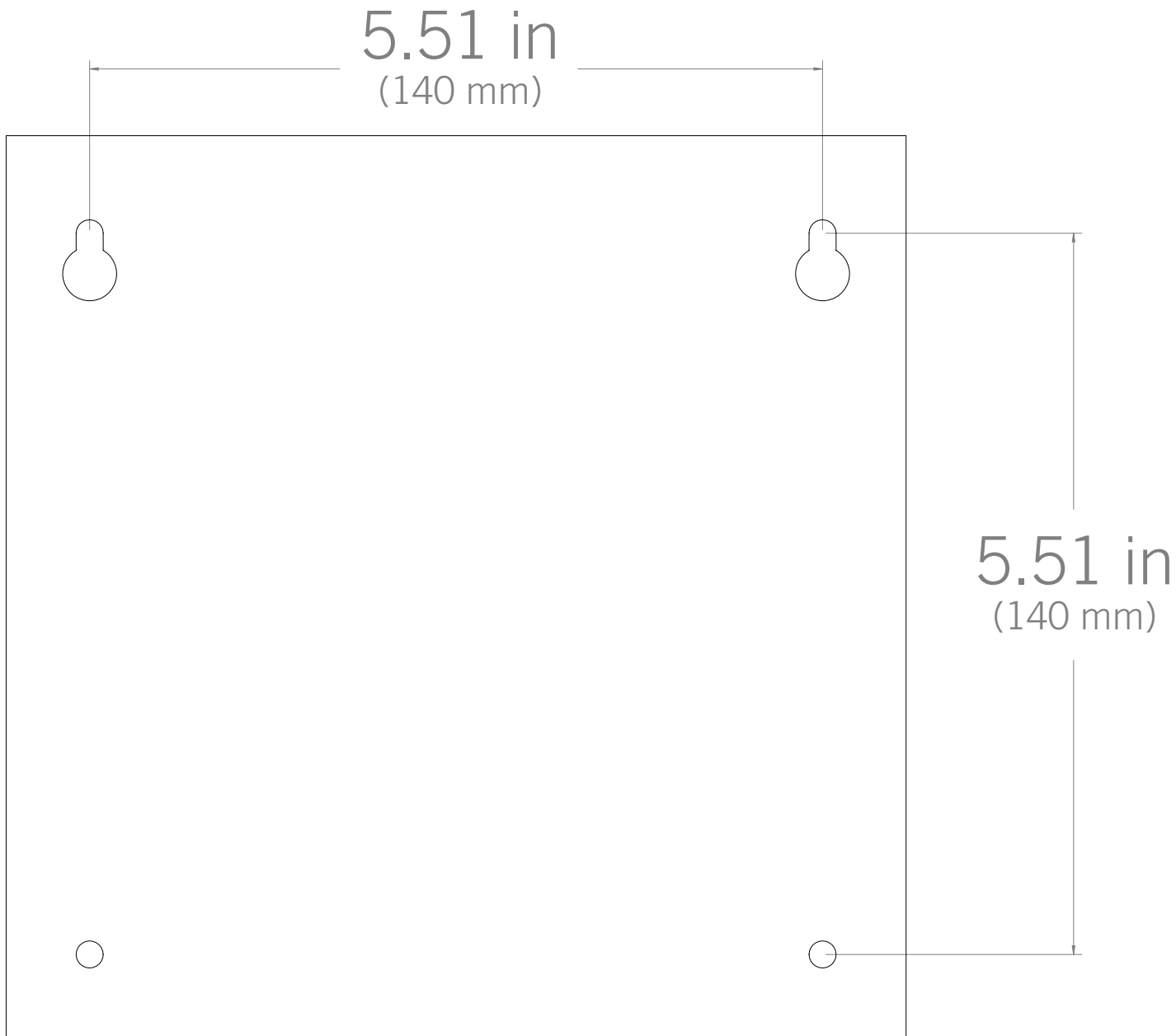



REFERENCE

# CONTROL PANEL

FOR REFERENCE ONLY

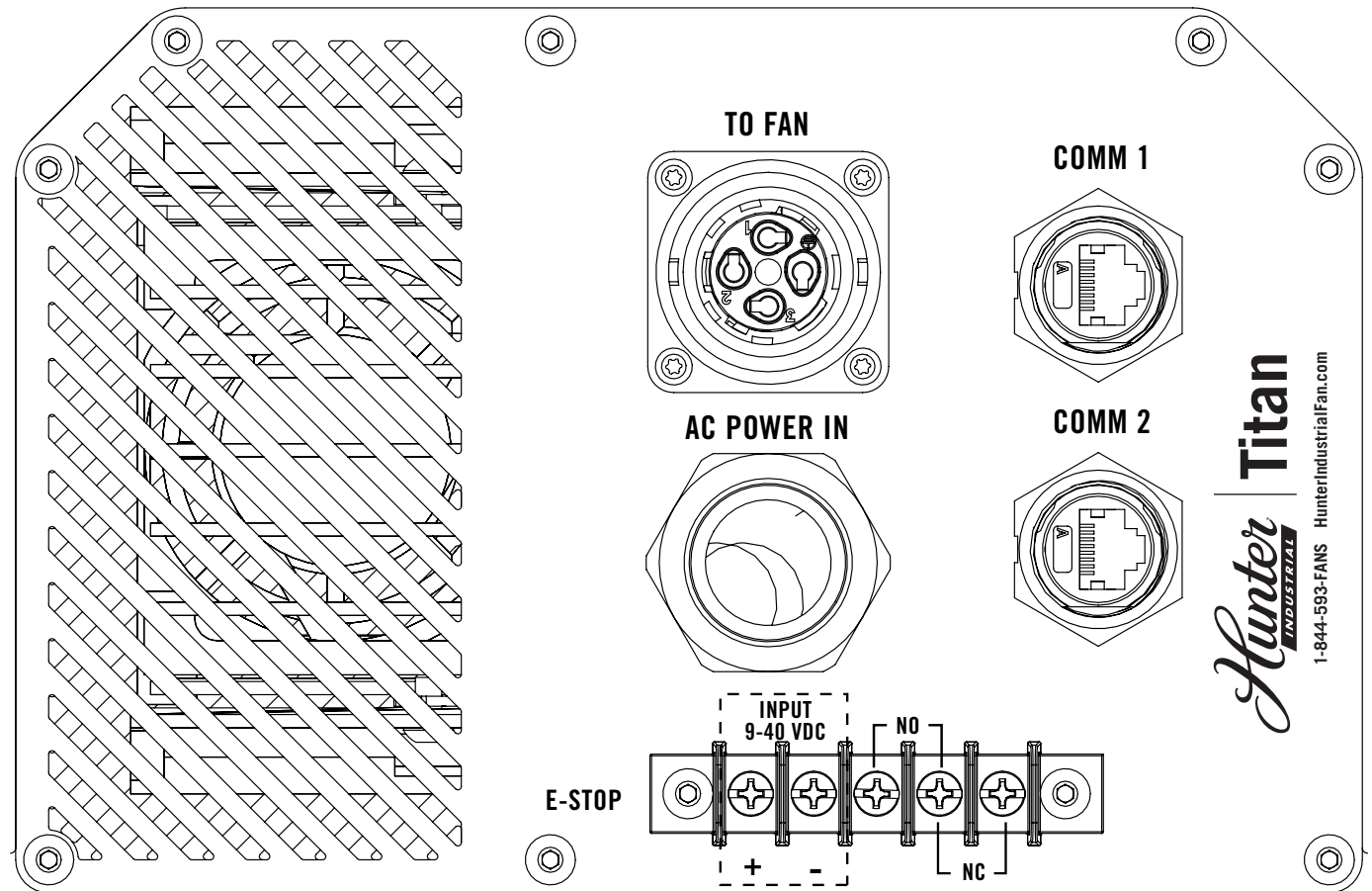



## FAN WILL NOT START

Check to see if all plugs are securely connected.

Verify the touchscreen has power.

Confirm supply power is adequate and functional.

## TOUCHSCREEN IS BLANK

Verify UI has power.

## FAULT SCREEN ON UI?

For fault codes, please call our  
**Technical Department at (844) 593-3267.**





2434 ATRIUM WAY  
NASHVILLE, TN 37214

1-844-591-3267  
TECHNICAL DEPARTMENT: 1-844-593-FANS (3267)

**HUNTERINDUSTRIALFAN.COM**