

# Instruction Manual

## HAND PALLET TRUCK ( TX SERIES )



**Note:** Owner/Operator must read and understand this instruction manual before using the hand pallet truck.

Thank you for choosing our pallet truck. For your safety and correct operation, please carefully read the manual before use.

**NOTE:** All of the information reported herein is based on data available at the time of printing. The factory reserves the right to modify its own products at any time without notice or incurring in any sanction. Please verify with the factory for possible updates.

## 1. GENERAL SPECIFICATIONS

Standard Model	TX20S	TX20L	TX25S	TX25L
Quick Lift Model	TXQ20S	TXQ20L	TXQ25S	TXQ25L
Capacity (kg)	2000	2000	2500	2500
Max. Fork Height (mm)	205(or195)			
Min. Fork Height (mm)	85(or75)			
Fork Length (mm)	1150	1220	1150	1220
Width Overall Forks (mm)	530	685	530	685
Individual Fork Width (mm)	150			
Load Wheel Diameter (mm)	80x60(or 70x60)Nylon , Polyurethane			
Steering Wheel Diameter (mm)	200(or 180)Nylon, Polyurethane, Rubber			
Net Weight (kg)	72	77	76	79

Special fork length are available 800, 900, 950, 1000, 1220,1500mm.

Materials and specification are subject to change without notice.

## 2. TO ATTACH HANDLE TO PUMP UNIT

- 2.1 Loosen the setting screw (140H) on the crank link (139H).
- 2.2 Remove three screws (H109) and three spring washers (H110) from the base (103).
- 2.3 Place the handle (H101, H101A, H101(JR), H101(FR)) on the base (103), please note: Feed the rod and chain (H107) through the centre of the base (103) and axle (109).
- 2.4 Insert three screws (H109) with spring washers (H110) into the base (103). Then tighten them securely.
- 2.5 Raise the crank link (139H) and put the pin on rod and chain (H107) into the groove of crank link (139H).

## 3. TO ADJUST RELEASE DEVICE

On the handle of the pallet truck, you will find the control lever (H106) which can be set in three positions (See Fig. 1):

LOWER=to lower the forks; NEUTRAL=to move the load; ASCENT=to raise the forks.

After assembling the handle, you can adjust the three positions.

- 3.1 First tighten the setting screw (140H) on the crank link (139H) until the LOWER position function works.
- 3.2 If the forks elevate while pumping in the NEUTRAL position, turn the setting screw (140H) clockwise until pumping the handle does not raise the forks and the NEUTRAL position functions correctly.
- 3.3 If the forks descend while pumping in the NEUTRAL position, turn the setting screw (140H) counter-clockwise until the forks do not lower.

- 3.4 If the forks do not descend when the control lever (H106) is in the LOWER position, turn the setting screw (140H) clockwise until raising the control lever (H106) lowers the forks. Then check the NEUTRAL position as per item 3.2 and 3.3.
- 3.5 If the forks do not lift while pumping in the ASCENT position, turn the setting screw (140H) counter-clockwise until the forks elevate while pumping in the ASCENT position. Then check the NEUTRAL and LOWER position as per item 3.2, 3.3 and 3.4.

## 4. MAINTENANCE

### 4.1 OIL

Please check the oil level every six months. The oil capacity is about 0.3lt. Restore the fluid level in the rubber reservoir to 5mm below the top, this must be with the forks in the lowered position.

Use the hydraulic type oil according to temperature scale below.

Temperature	Oil
-20 ~+40	L-HV46 Hydraulic oil

### 4.2 HOW TO EXPEL AIR FROM THE PUMP UNIT

Air may enter the unit when the seals are replaced. Lift the control lever (H106) to the LOWER position, then move the handle (H101, H101A, H101(JR), H101(FR)) up and down for several times.

### 4.3 DAILY CHECK AND MAINTENANCE

Daily check of the pallet truck can limit wear and tear of the unit. Pay special attention to the wheels (127, F1510, F1511), the axles (F1512, F1515, F1516), the handle (H101, H101A, H101(JR), H101(FR)), the forks (F1504) and lift and lower control.

### 4.4 LUBRICATION

Use motor oil or grease to lubricate all moveable parts.

## 5. GUIDE TO SAFETY OPERATION

For safe operation of the Hand Pallet Truck, please read all warning signs and instructions here and on the pallet truck prior to use.

- 5.1 Do not operate the pallet truck unless you are familiar with it and have been trained or authorised to do so.
- 5.2 Do not operate the truck unless you have been trained and authorised. Give special attention to the wheels, the handle assembly, the forks, and the lower control.
- 5.3 Do not use the truck on sloping ground.
- 5.4 Never place any part of your body in the lifting mechanism or under the forks or load. Do not carry passengers.
- 5.5 We advise that operators should wear gloves and safety shoes.
- 5.6 Do not handle unstable or loosely stacked loads.
- 5.7 Do not overload the truck.
- 5.8 Always place loads centrally across the forks and not at the end of the forks (See Fig. 2).

5.9 The capacity of the truck assumes an evenly distributed load with the centre of the load being at the halfway point of the length of the forks.

5.10 Make sure that length of the forks matches the length of the pallet.

5.11 Lower the forks to lowest height when the truck is not being used.

5.12 In other specific conditions the operators should take extra care in operating the truck.

## 6. TROUBLES SHOOTING

NO	TROUBLE	CAUSE	ACTION
1	The forks do not lift to maximum height.	-Not enough hydraulic oil.	-Add more oil.
2	The forks do not lift up.	-Not enough hydraulic oil. -The oil has impurities. -Discharge valve is out of adjustment. -Air in the hydraulic oil.	-Pour in more filtered oil. -Change the oil. -Adjust the setting screw (140H) (See item 3.5). -Expel the air (See item 4.2).
3	The forks do not descend.	-The rod (102) and the cylinder (159H) are deformed resulting from a seriously unbalanced load. -A part has been broken or been deformed resulting from unbalanced load. -The setting screw (140H) is not in the correct position.	-Replace the rod (102) or cylinder (159H).  -Repair or replace component.  -Adjust the setting screw (140H) (See item 3.4).
4	Leaks	-Seals worn out or damaged.  -Some parts may be cracked or worn out.	-Replace seals with new ones.  -Check and replace with new ones.
5	The forks descend without being lowered.	-Impurities in the oil cause the discharge valve (B) to fail to close. -Air in the oil. -Seals worn or damaged. -Discharge valve (B) is out of adjustment.	-Replace with filtered oil.  -Expel the air (See item 4.2). -Replace with new ones. -Adjust the setting screw (140H) (See item 3.3).

**\*NOTE: DO NOT ATTEMPT TO REPAIR THE PALLET TRUCK UNLESS YOU ARE TRAINED AND AUTHORIZED TO DO SO.**

Fig.1

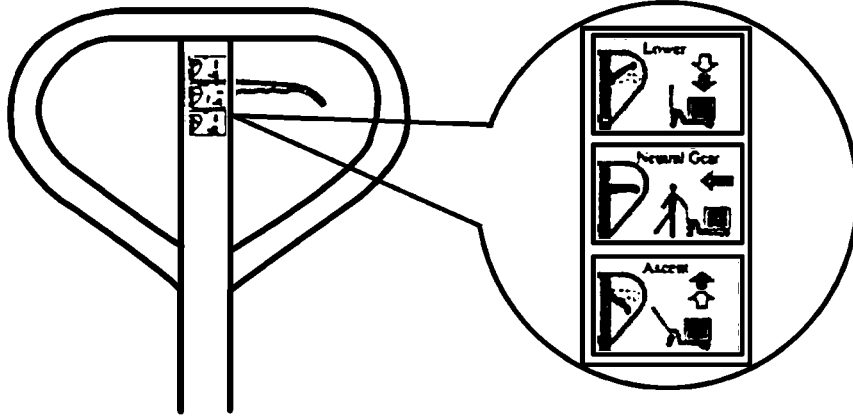
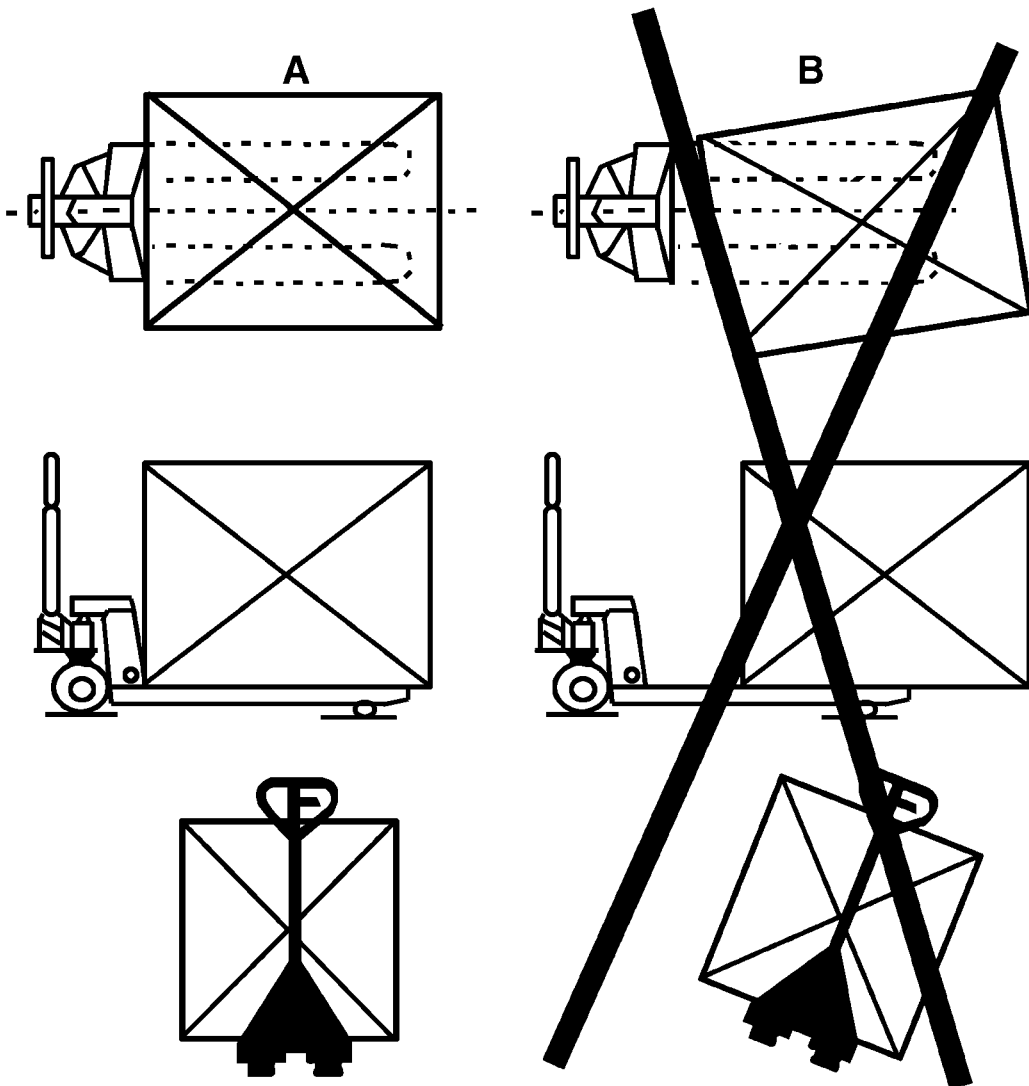
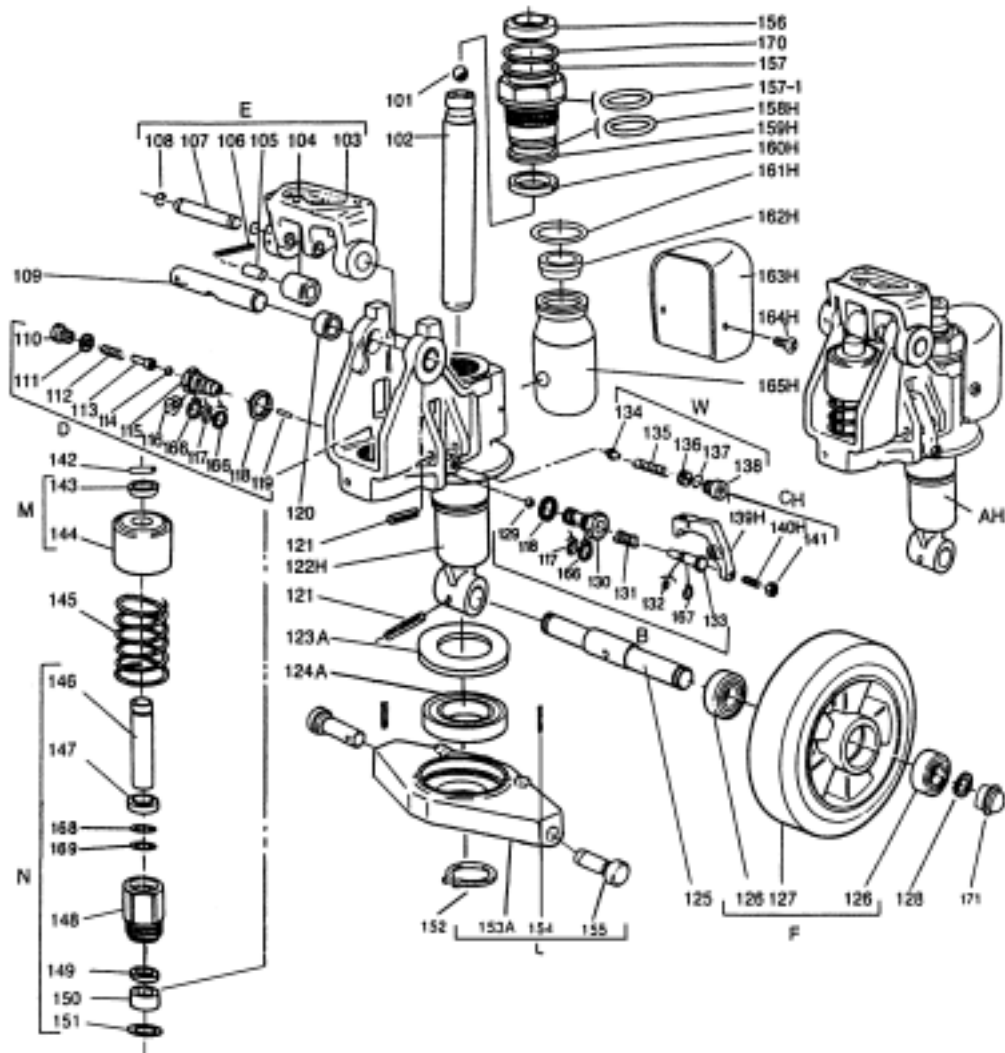

Fig.2



# Pump Assembly



## Parts List of Pump Assembly

PARTS NO.	DESCRIPTION	Q'TY	PARTS NO.	DESCRIPTION	Q'TY
101	Steel ball	1	136	Pressure regulating screw	1
102	Rod	1	137	O-ring	1
103	Base	1	138	Screw	1
104	Steel roller	1	139H	Crank link	1
105	Bushing	1	140H	Setting screw	1
106	Pin	1	141	Nut	1
107	Shaft	1	142	Parallel pin	1
108	Retaining ring	2	143	Retaining cover	1
109	Axle	1	144	Spring cover	1
110	Screw	1	145	Spring	1
111	Washer	1	146	Pump rod	1
112	Spring	1	147	Dust proof ring	1
113	Pressure rod	1	148	Pump cylinder	1
114	Steel ball	1	149	Seal ring	1
115	Pressure valve body	1	150	Nylon bushing	1
116	Split ring	1	151	Red copper washer	1
117	O-ring	2	152	Retaining ring	1
118	Washer	2	153A	Rhombus plate	1
119	Steel needle	1	154	Pin	2
120	Bushing	2	155	Dowel pin	2
121	Pin	2	156	Dust proof ring	1
122H	Pump body	1	157	O-ring	1
123A	Dust cover	1	157-1	O-ring	1
124A	Bearing	1	158H	O-ring	1
125	Steering wheel axle	1	159H	Cylinder	1
126	Bearing	4	160H	Seal ring	1
127A	Steering wheel, Nylon	2	161H	O-ring	1
127B	Steering wheel, Polyurethane	2	162H	Filler plug	1
127C	Steering wheel, Poly/Nylon	2	163H	Reservoir cover	1
127D	Steering wheel, Rubber	2	164H	Screw	2
128	Retaining ring	2	165H	Reservoir	1
129	Steel ball	1	166	Retainer	3
130	Discharge valve body	1	167	Retainer	1
131	Spring	1	168	Retainer	1
132	O-ring	1	169	O-ring	1
133	Discharge valve shaft	1	170	Retainer	1
134	Valve taper core	1	171	Dust cover	2
135	Spring	1			

# Quick Lift Pump Assembly

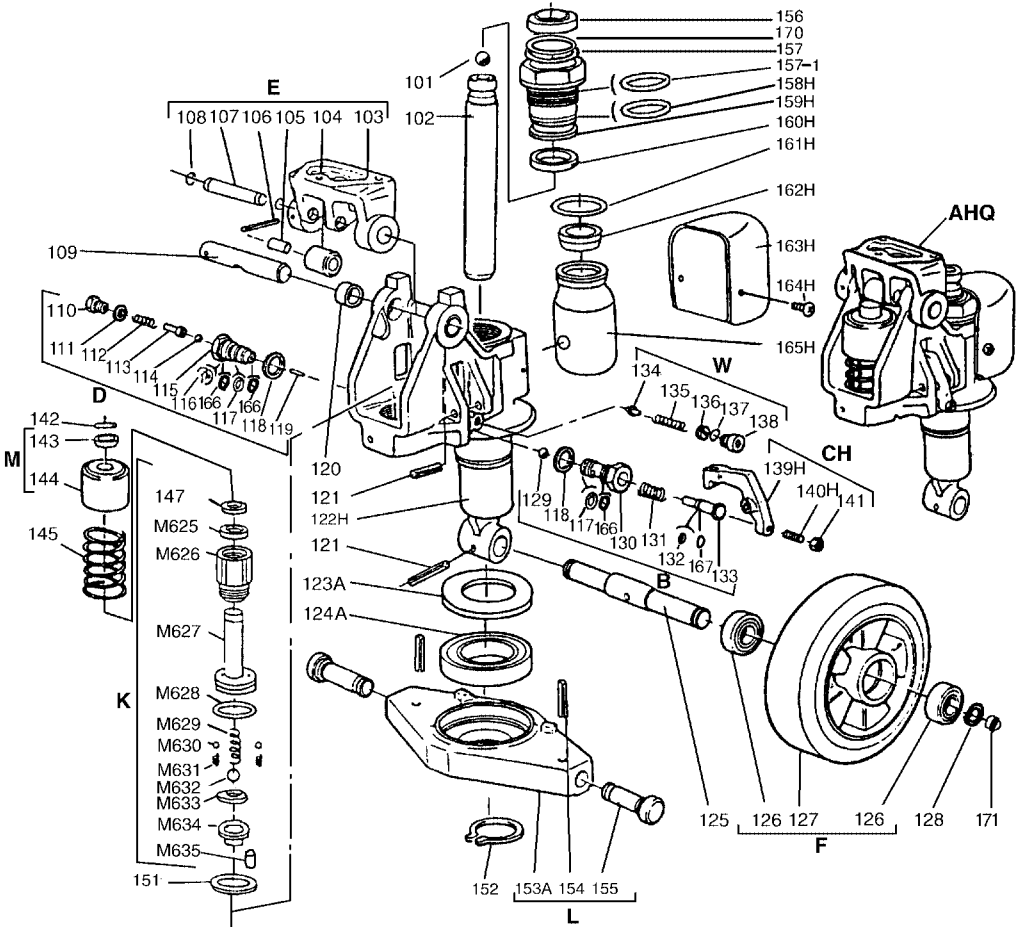



## Parts List of Quick Lift Pump Assembly

PARTS NO.	DESCRIPTION	Q'TY	PARTS NO.	DESCRIPTION	Q'TY
101	Steel ball	1	138	Screw	1
102	Rod	1	139H	Crank link	1
103	Base	1	140H	Setting screw	1
104	Steel roller	1	141	Nut	1
105	Bushing	1	142	Parallel pin	1
106	Pin	1	143	Retaining cover	1
107	Shaft	1	144	Spring cover	1
108	Retaining ring	2	145	Spring	1
109	Axle	1	147	Dust proof ring	1
110	Screw	1	151	Red copper washer	1
111	Washer	1	152	Retaining ring	1
112	Spring	1	153A	Rhombus plate	1
113	Pressure rod	1	154	Pin	2
114	Steel ball	1	155	Dowel pin	2
115	Pressure valve body	1	156	Dust proof ring	1
116	Split ring	1	157	O-ring	1
117	O-ring	2	157-1	O-ring	1
118	Washer	2	158H	O-ring	1
119	Steel needle	1	159H	Cylinder	1
120	Bushing	2	160H	Seal ring	1
121	Pin	2	161H	O-ring	1
122H	Pump body	1	162H	Filler plug	1
123A	Dust cover	1	163H	Reservoir cover	1
124A	Bearing	1	164H	Screw	2
125	Steering wheel axle	1	165H	Reservoir	1
126	Bearing	4	166	Retainer	3
127A	Steering wheel, Nylon	2	167	Retainer	1
127B	Steering wheel, Polyurethane	2	170	Retainer	1
127C	Steering wheel, Poly/Nylon	2	171	Dust cover	2
127D	Steering wheel, Rubber	2	M625	Seal ring	1
128	Retaining ring	2	M626	Pump cylinder	1
129	Steel ball	1	M627	Pump rod	1
130	Discharge valve body	1	M628	O-ring	1
131	Spring	1	M629	Big spring	1
132	O-ring	1	M630	Steel ball	2
133	Discharge valve shaft	1	M631	Small spring	2
134	Valve taper core	1	M632	Steel ball	1
135	Spring	1	M633	Spring base	1
136	Pressure regulating screw	1	M634	Plug	1
137	O-ring	1	M635	Pin	1

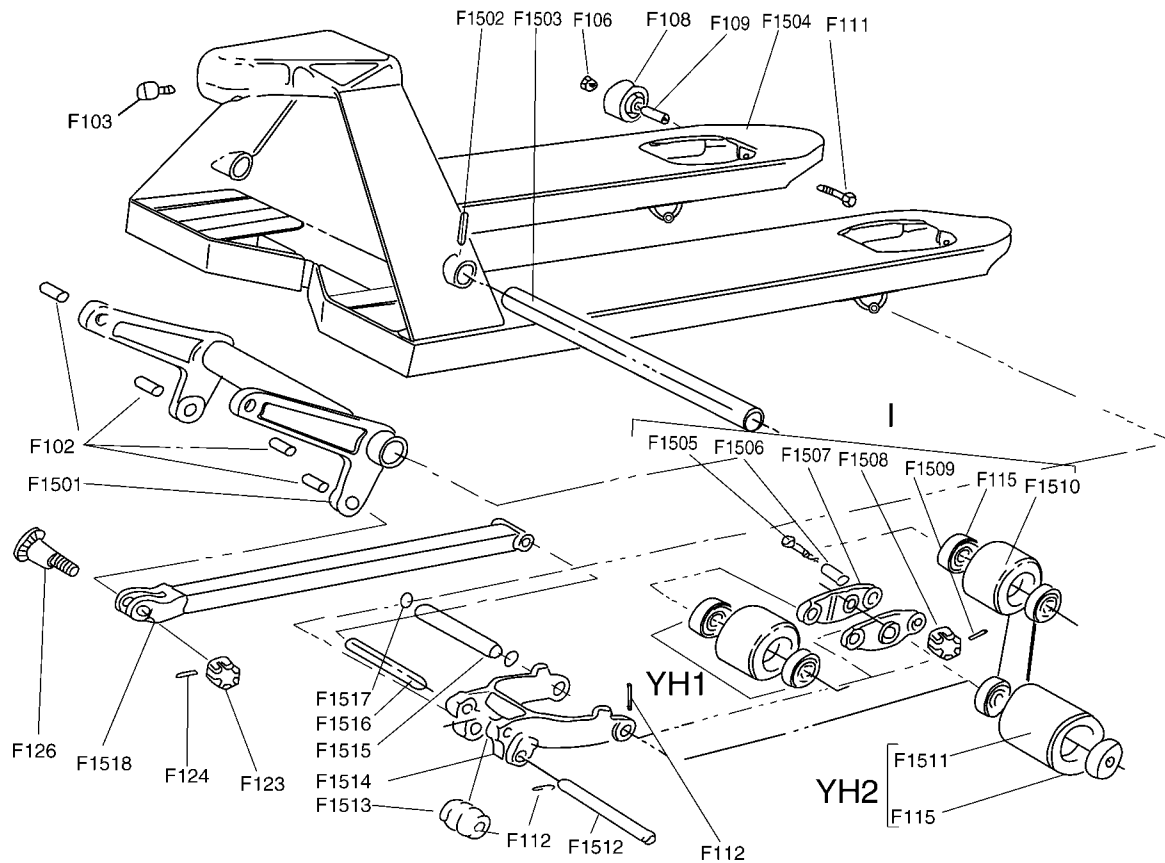

## Parts List of Frame

PARTS NO.	DESCRIPTION	Q'TY	PARTS NO.	DESCRIPTION	Q'TY
F1501	Torsion tube assembly	1	F1514	H-link	2
F1502	Spring pin	1	F1515	Axle	2
F1503	Torsion tube shaft	1	F1516	Axle	2
F1504	Frame	1	F1517	Washer	4
F1505	Bolt	4	F1518	Pull rod	2
F1506	Bushing	4	F102	Bushing	4
F1507	Plate	4	F103	Screw	1
F1508	Nut	4	F106	Nut	2
F1509	Pin	4	F108	Roller	2
F1510A	Nylon load roller, tandem type	4	F109	Bushing	2
F1510B	Poly load roller, tandem type	4	F111	Bolt	2
F1510C	Poly/Nylon load roller, tandem type	4	F112	Spring pin	4
F1511A	Nylon load roller, single type	2	F115	Bearing	8/4
F1511B	Poly load roller, single type	2	F123	Nut	2
F1511C	Poly/Nylon load roller, single type	2	F124	Pin	2
F1512	Axle	2	F126	Pin	2
F1513	Roller	2			

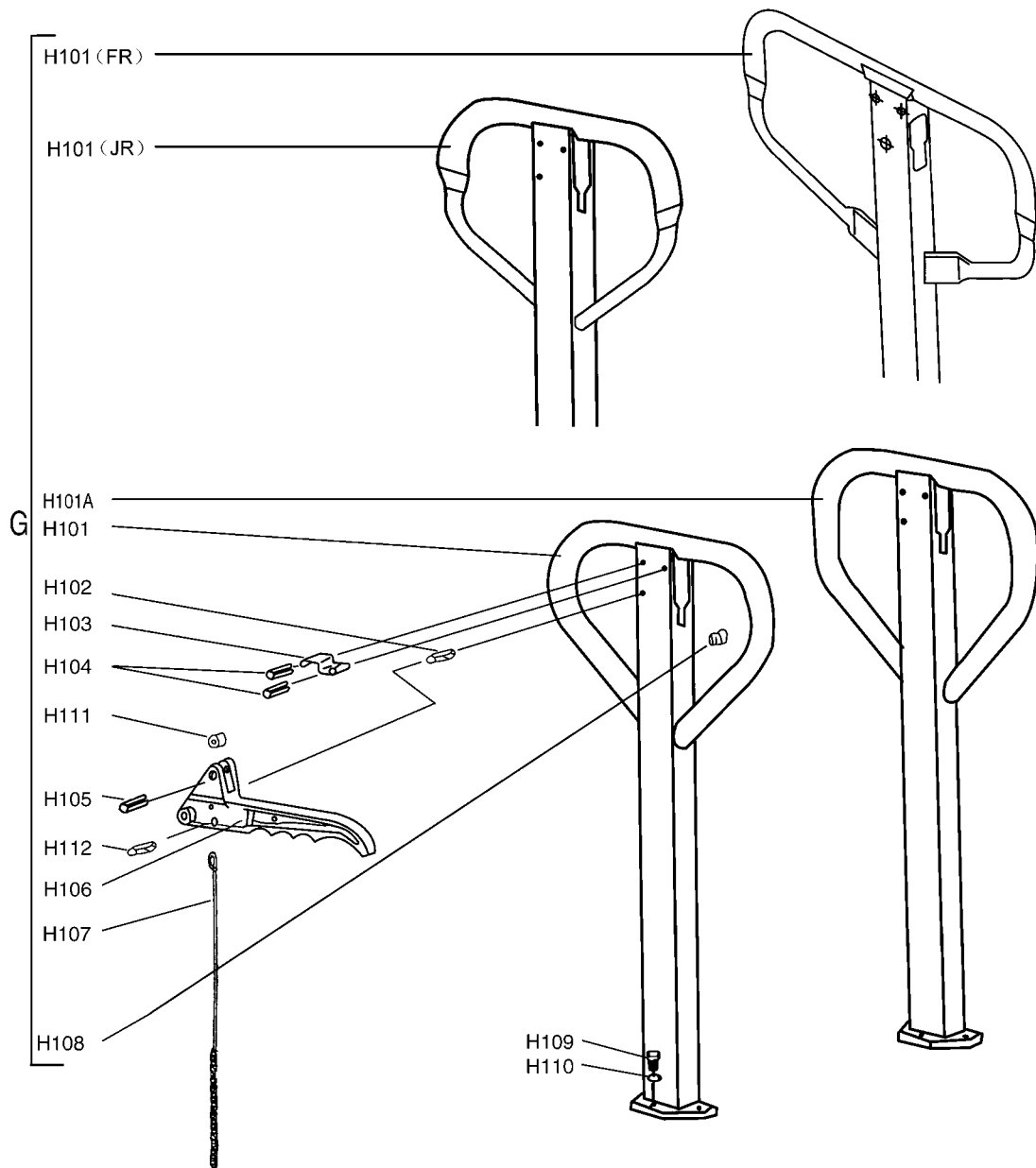

### Parts List of Handle

PARTS NO.	DESCRIPTION	Q'TY	PARTS NO.	DESCRIPTION	Q'TY
H101	Handle	1	H106	Control lever	1
H101A	Handle	1	H107	Rod and chain	1
H101(JR)	Handle	1	H108	Rubber cushion	1
H101(FR)	Handle	1	H109	Screw	3
H102	Spring pin	1	H110	Spring washer	3
H103	Spring leaf	1	H111	Nylon roller	1
H104	Spring pin	2	H112	Spring pin	1
H105	Spring pin	1			

# Assembly list

Assembly	Description
AH	Pump unit
AHQ	Quick lift pump unit
B	Lowering valve ass'y
CH	Lowering screw ass'y
D	Hydraulic valve ass'y
E	Handle seat ass'y
F1	Nylon steering wheel ass'y
F2	Polyurethane steering wheel ass'y
F3	Polyurethane/Nylon steering wheel ass'y
F4	Rubber steering wheel ass'y
G	Handle ass'y
YH1A	Nylon load roller ass'y (tandem type)
YH1B	Polyurethane load roller ass'y (tandem type)
YH1C	Polyurethane/Nylon load roller ass'y (tandem type)
YH2A	Nylon load roller ass'y (single type)
YH2B	Polyurethane load roller (single type)
YH2C	Polyurethane/Nylon load roller ass'y (single type)
I1	Tandem nylon load roller system ass'y
L	Rhombus plate ass'y
K	Quick lift pump piston ass'y
M	Spring cover ass'y
N	Pump piston ass'y
W	Safety valve ass'y
SH	*Seal kit
SHQ	*Seal kit

\*Note: Seal kit include following parts: 111, 117, 118, 132, 137, 147, 149, 151, 156, 157, 157-1, 158H, 160H, 161H, 169, M625, M628.