



Operation and Maintenance Instructions

Belt Drive Bench Lathe, 13x40-inch

Model BDB-1340A



(shown with optional 321443AK stand)

For Parts List and Electrical Diagrams, see document M-321357A

JET

427 New Sanford Road
LaVergne, Tennessee 37086
Ph.: 800-274-6848
www.jettools.com

Part No. M-321360A
Revision G3 11/2014
Copyright © 2014 JET

Warranty and Service

JET warrants every product it sells against manufacturers' defects. If one of our tools needs service or repair, please contact Technical Service by calling 1-800-274-6846, 8AM to 5PM CST, Monday through Friday.

Warranty Period

The general warranty lasts for the time period specified in the literature included with your product or on the official JET branded website.

- JET products carry a limited warranty which varies in duration based upon the product. (See chart below)
- Accessories carry a limited warranty of one year from the date of receipt.
- Consumable items are defined as expendable parts or accessories expected to become inoperable within a reasonable amount of use and are covered by a 90 day limited warranty against manufacturer's defects.

Who is Covered

This warranty covers only the initial purchaser of the product from the date of delivery.

What is Covered

This warranty covers any defects in workmanship or materials subject to the limitations stated below. This warranty does not cover failures due directly or indirectly to misuse, abuse, negligence or accidents, normal wear-and-tear, improper repair, alterations or lack of maintenance. JET woodworking machinery is designed to be used with Wood. Use of these machines in the processing of metal, plastics, or other materials may void the warranty. The exceptions are acrylics and other natural items that are made specifically for wood turning.

Warranty Limitations

Woodworking products with a Five Year Warranty that are used for commercial or industrial purposes default to a Two Year Warranty. Please contact Technical Service at 1-800-274-6846 for further clarification.

How to Get Technical Support

Please contact Technical Service by calling 1-800-274-6846. **Please note that you will be asked to provide proof of initial purchase when calling.** If a product requires further inspection, the Technical Service representative will explain and assist with any additional action needed. JET has Authorized Service Centers located throughout the United States. For the name of an Authorized Service Center in your area call 1-800-274-6846 or use the Service Center Locator on the JET website.

More Information

JET is constantly adding new products. For complete, up-to-date product information, check with your local distributor or visit the JET website.

How State Law Applies

This warranty gives you specific legal rights, subject to applicable state law.

Limitations on This Warranty

JET LIMITS ALL IMPLIED WARRANTIES TO THE PERIOD OF THE LIMITED WARRANTY FOR EACH PRODUCT. EXCEPT AS STATED HEREIN, ANY IMPLIED WARRANTIES OF MERCHANTABILITY AND FITNESS FOR A PARTICULAR PURPOSE ARE EXCLUDED. SOME STATES DO NOT ALLOW LIMITATIONS ON HOW LONG AN IMPLIED WARRANTY LASTS, SO THE ABOVE LIMITATION MAY NOT APPLY TO YOU.

JET SHALL IN NO EVENT BE LIABLE FOR DEATH, INJURIES TO PERSONS OR PROPERTY, OR FOR INCIDENTAL, CONTINGENT, SPECIAL, OR CONSEQUENTIAL DAMAGES ARISING FROM THE USE OF OUR PRODUCTS. SOME STATES DO NOT ALLOW THE EXCLUSION OR LIMITATION OF INCIDENTAL OR CONSEQUENTIAL DAMAGES, SO THE ABOVE LIMITATION OR EXCLUSION MAY NOT APPLY TO YOU.

JET sells through distributors only. The specifications listed in JET printed materials and on official JET website are given as general information and are not binding. JET reserves the right to effect at any time, without prior notice, those alterations to parts, fittings, and accessory equipment which they may deem necessary for any reason whatsoever. JET® branded products are not sold in Canada by JPW Industries, Inc.

Product Listing with Warranty Period

90 Days – Parts; Consumable items; Light-Duty Air Tools
1 Year – Motors; Machine Accessories; Heavy-Duty Air Tools; Pro-Duty Air Tools
2 Year – Metalworking Machinery; Electric Hoists, Electric Hoist Accessories; Woodworking Machinery used for industrial or commercial purposes
5 Year – Woodworking Machinery
Limited Lifetime – JET Parallel clamps; VOLT Series Electric Hoists; Manual Hoists; Manual Hoist Accessories; Shop Tools; Warehouse & Dock products; Hand Tools

NOTE: JET is a division of JPW Industries, Inc. References in this document to JET also apply to JPW Industries, Inc., or any of its successors in interest to the JET brand.

Table of Contents

Warranty and Service	2
Table of Contents	3
Warning.....	3
Specifications	5
Dimensions of optional stand (p/n 321443AK).....	6
Assembly	6
Contents of the Shipping Container	6
Uncrating and Clean-Up.....	7
Chuck Preparation (Three Jaw).....	8
Lubrication	9
Electrical Connections.....	11
General Description.....	11
Controls	13
Adjustments	15
Break-In Procedure.....	15
Speed Selection.....	15
Feed and Thread Selection	15
Change Gear Replacement.....	16
Thread Cutting	16
Thread and Feed Chart.....	17
Automatic Feed Operation and Feed Changes	18
Powered Carriage Travel	18
Saddle Adjustment.....	18
Cross Slide Adjustment.....	18
Compound Rest Adjustment.....	19
Tailstock Adjustment.....	19
Half Nut Gib Adjustment.....	19
Headstock Alignment	19
Removing Gap Section	20
Installing Gap Section	20

Warnings

1. Read and understand the entire contents of this manual before attempting assembly or operation.
2. Read and understand the warnings posted on the machine and in this manual. Failure to comply with all of these warnings may cause serious injury.
3. This manual is intended to familiarize you with the technical aspects of this lathe. It is not, nor was it intended to be, a training manual.
4. This machine is designed and intended for use by properly trained and experienced personnel only. If you are not familiar with the proper and safe operation of a lathe, do not use until proper training and knowledge have been obtained.
5. Always wear approved safety glasses/face shields while using this lathe. Everyday eyeglasses only have impact resistant lenses; they are not safety glasses.
6. Wear proper apparel. Remove tie, rings, watches and other jewelry, and roll sleeves up past the elbows. Remove all loose clothing and confine long hair. Non-slip footwear or anti-skid floor strips are recommended. Do **not** wear gloves.
7. Wear ear protectors (plugs or muffs) during extended periods of operation.
8. Do not operate this machine while tired or under the influence of drugs, alcohol or any medication.
9. Make certain the switch is in the **OFF** position before connecting the machine to the power supply.
10. Make certain the machine is properly grounded.

Warnings

11. Do not place hands near the chuck while the machine is operating.
12. Make all machine adjustments or maintenance with the machine unplugged from the power source.
13. Remove adjusting keys and wrenches. Form a habit of checking to see that keys and adjusting wrenches are removed from the machine before turning it on.
14. Some dust created by power sanding, sawing, grinding, drilling and other construction activities contains chemicals known to cause cancer, birth defects or other reproductive harm. Some examples of these chemicals are:
 - Lead from lead based paint.
 - Crystalline silica from bricks, cement and other masonry products.
 - Arsenic and chromium from chemically treated lumber.Your risk of exposure varies, depending on how often you do this type of work. To reduce your exposure to these chemicals, work in a well-ventilated area and work with approved safety equipment, such as face or dust masks that are specifically designed to filter out microscopic particles.
15. Keep safety guards in place at all times when the machine is in use. If removed for maintenance purposes, use extreme caution and replace the guards immediately after maintenance is complete.
16. Check damaged parts. Check for alignment of moving parts, binding of moving parts, breakage of parts, mounting and any other conditions that may affect its operation. A guard or other part that is damaged should be properly repaired or replaced.
17. Keep the floor around the machine clean and free of scrap material, oil and grease.
18. Keep visitors a safe distance from the work area. **Keep children away.**
19. Make your workshop child proof with padlocks, master switches or by removing starter keys.
20. Give your work undivided attention. Looking around, carrying on a conversation and “horse-play” are careless acts that can result in serious injury.
21. Do not overreach. Keep proper footing and balance at all times.
22. Use the right tool. Do not force a tool or attachment to do a job for which it was not designed. The right tool will do the job better and safer.
23. Use recommended accessories; improper accessories may be hazardous.
24. Maintain tools with care. Keep tools sharp and clean for the best and safest performance. Follow instructions for lubricating and changing accessories.
25. Turn off the machine and disconnect from power before cleaning. Use a brush or compressed air to remove chips or debris — do not use your hands.
26. Never leave the machine running unattended. Turn the power off and do not leave the machine until it comes to a complete stop.
27. Remove loose items and unnecessary work pieces from the area before starting the machine.

Familiarize yourself with the following safety notices used in this manual:

CAUTION This means that if precautions are not heeded, it may result in minor injury and/or possible machine damage.

WARNING This means that if precautions are not heeded, it may result in serious injury or possibly even death.

Specifications

Model Number..... BDB-1340A
Stock Number..... 321360A

Capacities:

Swing Over Bed 13"
Swing Over Cross Slide..... 7-25/32"
Swing Through Gap..... 18-3/4"
Length of Gap..... 8"
Distance Between Centers 40"

Headstock:

Hole Through Spindle 1-3/8"
Spindle Nose D1-4
Taper in Spindle Nose MT-5
Spindle Taper Adapter..... MT-3
Spindle Bearing Type Taper Roller Bearing
Number of Spindle Speeds 12
Range of Spindle Speeds 60-1240 rpm

Gearbox:

Number of Longitudinal and Cross Feeds 22/22
Range of Longitudinal Feeds (inch/rev)..... 0.0018" – 0.0374"
Range of Cross Feeds (inch/rev) 0.0012" – 0.0345"
Number of Inch Threads 40
Range of Inch Threads 3-1/2 – 80 TPI
Number of Metric Threads 27
Range of Metric Threads 0.2 – 6mm
Leadscrew..... 7/8" x 8 TPI
Feed Rod Diameter 3/4"

Compound and Carriage:

Toolpost Type..... 4-Way
Maximum Tool Size 5/8" x 5/8"
Maximum Compound Slide Travel 2-11/16"
Maximum Cross Slide Travel 6-5/16"
Maximum Carriage Travel..... 35"

Tailstock:

Tailstock Spindle Travel..... 3-3/4"
Diameter of Tailstock Spindle 1-1/4"
Taper in Tailstock Spindle..... MT-3

Miscellaneous:

Steady Rest Capacity 1/4" – 2-5/8"
Follow Rest Capacity 1/4" – 2-3/4"
Length of Bed..... 54"
Width of Bed..... 7-3/8"
Height of Bed..... 12"
Overall Dimensions 71"L x 32"W x 25-1/2"H
Main Motor 2HP, 1PH, 230V only
Net Weight (approx.)..... 1,070 lbs.
Shipping Weight (approx.) 1,280 lbs.

The above specifications were current at the time this manual was published, but because of our policy of continuous improvement, JET reserves the right to change specifications at any time and without prior notice, without incurring obligations.

Dimensions of optional stand (p/n 321443AK)

To purchase this optional stand for the BDB-1340A Lathe, contact your dealer or call JET customer service.

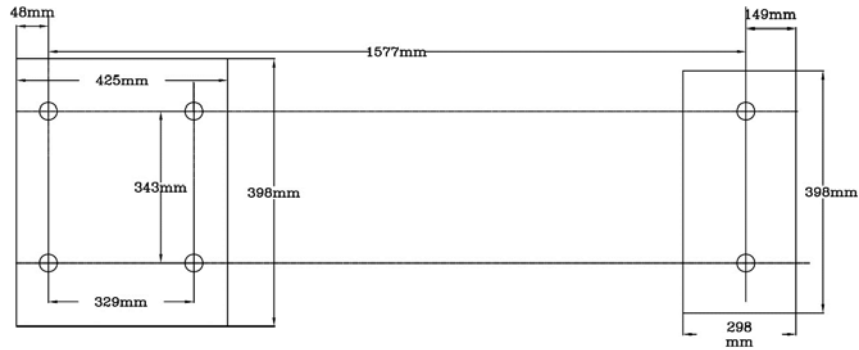

height: 598mm

Assembly

Contents of the Shipping Container

(Figures 1 and 2)

- 1 Lathe
- 1 Steady Rest (mounted on lathe)
- 1 Follow Rest (mounted on lathe)
- 1 6" Three Jaw Chuck (mounted on lathe)
- 1 8" Four Jaw Chuck
- 1 12" Face Plate (strapped to container)
- 3 Cam Locks
- 3 Socket Head Cap Screws
- 1 Tool Box (strapped to container)
- 1 Chip Tray
- 1 Lifting Hook
- 2 Lifting Blocks

Tool Box:

- 3 Open End Wrenches (9/11, 10/12, 12/14mm)
- 1 Touch-Up Paint
- 1 Oil Can
- 1 Hex Socket Wrench Set (2.5, 3, 4, 5, 6, 8mm)
- 2 Shear Pins
- 1 33T Gear
- 1 44T Gear
- 1 46T Gear
- 1 48T Gear
- 1 52T Gear
- 2 T-Handle Chuck Wrenches
- 1 Tool Post Wrench
- 2 MT-3 Centers
- 1 MT-3 to MT-5 Sleeve

- 1 Cross Point Screwdriver
- 1 Flat Head Screwdriver
- 1 Key for Cam Locks
- 1 Operating Instructions
- 1 Parts List
- 1 Warranty Card



Figure 1
(stand not included)



Figure 2

⚠WARNING Machine is heavy! Use an appropriate lifting device and use extreme caution when moving the machine to its final location. Failure to comply may cause serious injury.

Uncrating and Clean-Up

1. Finish removing the wooden crate from around the lathe.
2. Unbolt the lathe from the shipping crate bottom.
3. Choose a location for the lathe that is dry, has good lighting, and has enough room to be able to service the lathe on all four sides.
4. Assemble parts fastened to the crate bottom used to lift the lathe. See Fig. 3. (**Note:** Lifting parts are not tightened in Fig. 3 to show detail.) Using a piece of leather or a block of wood under the metal block to protect the ways during lifting is highly recommended. **Do not lift the lathe by the spindle.** With adequate lifting equipment, slowly raise the lathe off the shipping crate bottom. Make sure lathe is balanced before moving to a sturdy bench or optional stand.
5. To avoid twisting the bed, the lathe's location must be absolutely flat and level. Bolt the lathe to the stand (if used). If using a bench, through-bolt for best performance.
6. Clean all rust protected surfaces using a mild commercial solvent, kerosene or diesel fuel. Do not use paint thinner, gasoline, or lacquer thinner. These will damage painted surfaces. Cover all cleaned surfaces with a light film of Mobil DTE® Oil Heavy Medium.
7. Remove the end gear cover. Clean all components of the end gear assembly and coat all gears with a heavy, non-slinging grease.
8. Using a machinist's precision level on the bedways, check to make sure lathe is level side to side and front to back. Loosen mounting bolts, shim, and tighten mounting bolts, if necessary. The lathe must be level to be accurate.

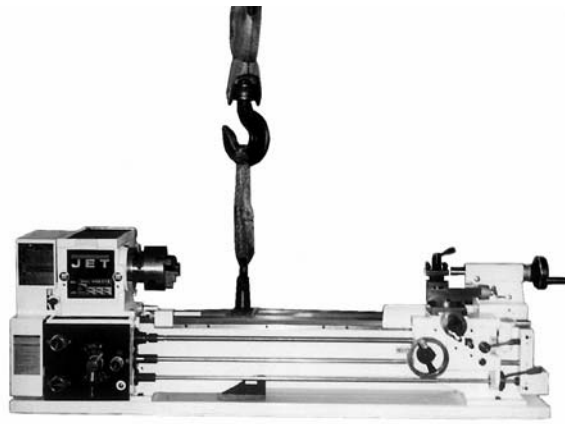

Figure 3

Chuck Preparation (Three Jaw)

⚠WARNING Read and understand all directions for chuck preparation! Failure to comply may cause serious injury and/or damage to the lathe!

Note: Before removing the chuck from the spindle, place a way board across the bedways under the chuck.

1. Support the chuck while turning three camlocks 1/4 turn counter-clockwise with the chuck key which is included in the tool box.
2. Carefully remove the chuck from the spindle and place on an adequate work surface.
3. Inspect the camlock studs. Make sure they have not become cracked or broken during transit. Clean all parts thoroughly with solvent. Also clean the spindle and camlocks.
4. Cover all chuck jaws and scroll inside the chuck with #2 lithium tube grease. Cover the spindle, cam locks, and chuck body with a light film of Mobil DTE® Oil Heavy Medium.
5. Lift the chuck up to the spindle nose and press onto the spindle. Tighten in place by turning the cam locks 1/4 turn clockwise. The index mark (A, Fig. 4) on the camlock should be between the two indicator arrows (B, Fig. 4) when tight. If the index mark is not between the two arrows, remove the chuck and adjust the camlock studs by either turning out one full turn (if cams will not engage) or turning in one full turn (if cams turn beyond indicator marks).
6. Install chuck and tighten in place.

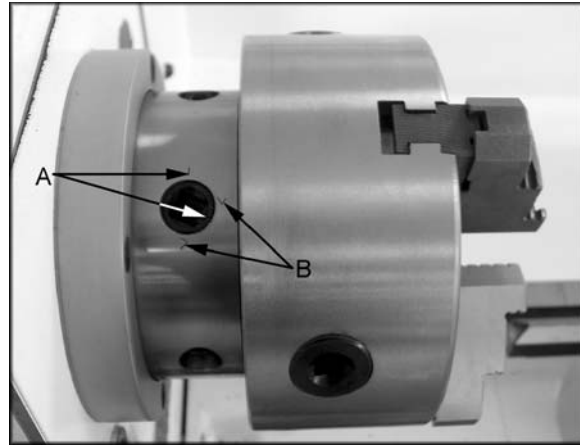

Figure 4

Lubrication

CAUTION Lathe must be serviced at all lubrication points and all reservoirs filled to operating level before the lathe is placed into service. Failure to comply may cause serious damage to the lathe.

1. **Headstock** - Oil must be up to indicator mark in both oil sight glasses (A, Fig. 5). Top off with Mobil DTE® Oil Heavy Medium. The headstock should be drained and refilled after the first three months of operation. Then, change oil in the headstock annually.

Drain oil completely by removing drain plugs (B, Fig. 5). Also loosen the three set screws in the pulleys (K, Fig. 6) and shaft (E, Fig. 6) and drain the oil from these. When done, re-tighten the set screws (K,E) and re-insert the drain plugs (B). Refill by removing fill plugs (C, Fig. 6). Grease three fittings (D, Fig. 7) with Mobil 1® Synthetic Universal Grease daily.

2. **External Gears** - Coat all gears with a heavy, non-slinging grease, see Figure 7.
3. **Center Back Gear Shaft** - Remove the set screw on the shaft (E, Fig. 6) and oil with a couple of drops of Mobil DTE® Oil Heavy Medium once weekly.
4. **Quick Change Gearbox** - Oil must be up to indicator mark in oil sight glass (F, Fig. 5). Top off with Mobil DTE® Oil Heavy Medium. Fill by removing plug (G, Fig. 7). Drain oil by removing drain plug (H, Fig. 7) and refill after the first month of operation. Then, change oil in the gearbox annually.

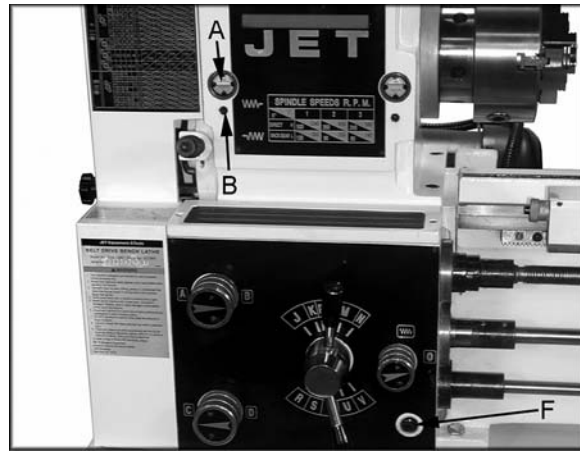

Figure 5

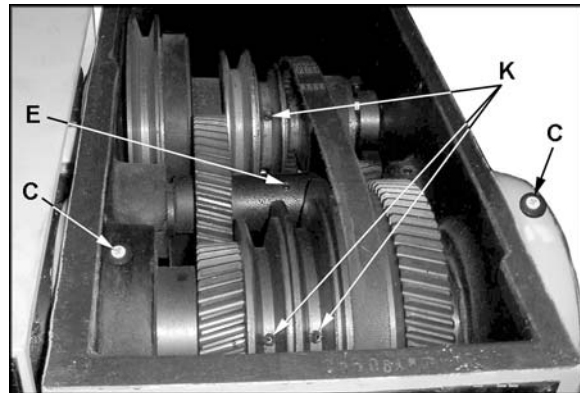

Figure 6

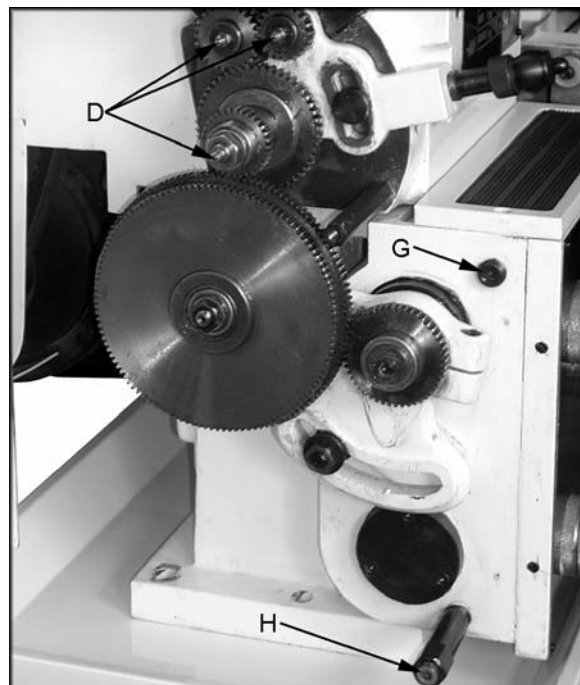

Figure 7

5. **Apron** - Oil must be up to indicator mark in oil sight glass (A, Fig. 8). Top off with Mobil DTE® Oil Heavy Medium. Fill by removing oil plug (B, Fig. 8). After the first three months of operation, drain oil completely (drain is on the bottom of the apron) and refill with Mobil DTE® Oil Heavy Medium, at a level equivalent to the indicator line. Then, change oil annually.

6. **Feed Selector** - Lubricate ball oiler (C, Fig. 8) once daily with Mobil DTE® Oil Heavy Medium.

7. **Carriage** - Lubricate two ball oilers (D, Fig. 8) once daily with Mobil DTE® Oil Heavy Medium.

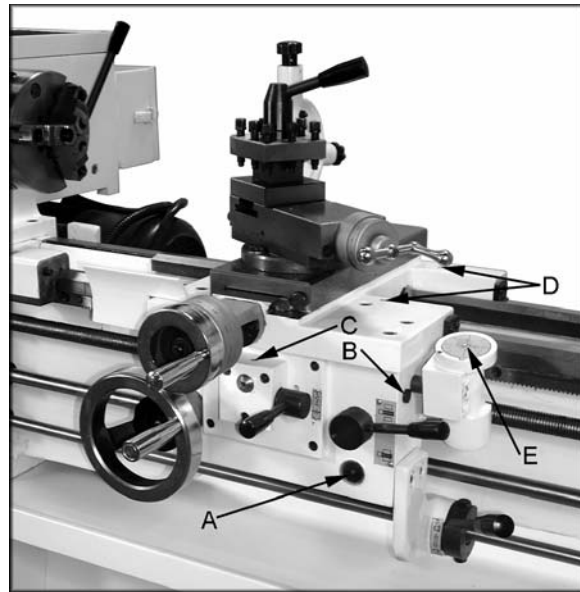

Figure 8

8. **Thread Dial Indicator** - Lubricate ball oiler (E, Fig. 8) once daily with Mobil DTE® Oil Heavy Medium.

9. **Compound Rest** - Lubricate three ball oilers (F, Fig. 9) once daily with Mobil DTE® Oil Heavy Medium.

10. **Cross Slide** - lubricate four ball oilers (G, Fig. 9) once daily with Mobil DTE® Oil Heavy Medium.

11. **Longitudinal Feed Handwheel** - Lubricate ball oiler (H, Fig. 9) once daily with Mobil DTE® Oil Heavy Medium.

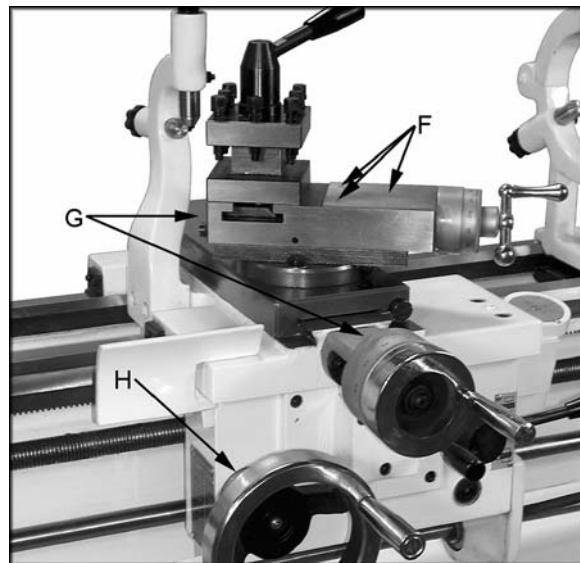

Figure 9

12. **Tailstock** - Lubricate three ball oilers (I, Fig. 10) once daily with Mobil DTE® Oil Heavy Medium.

13. **Leadscrew/Feed Rod** - Lubricate three ball oilers once daily (J, Fig. 10) with Mobil DTE® Oil Heavy Medium.

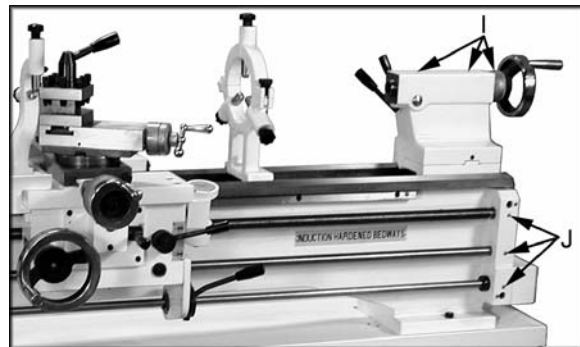

Figure 10

Electrical Connections

⚠WARNING All electrical connections must be completed by a qualified electrician and must comply with all relevant codes. Failure to comply may cause serious injury and/or damage to the machinery and property.

The BDB-1340A bench lathe is rated at **2HP, 1PH, 230V only**. Confirm that power available at the lathe's location is the same rating as the lathe.

Make sure the lathe is properly grounded.

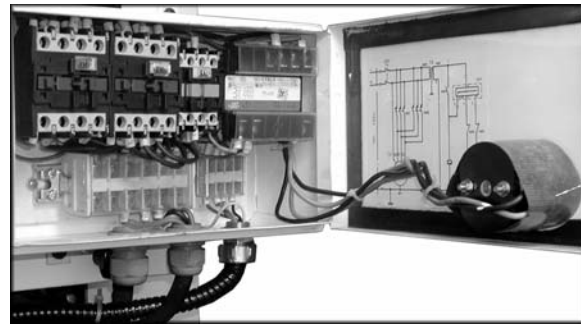

Figure 11

General Description

Lathe Bed

The lathe bed (A, Fig. 12) is made of high grade cast iron. By combining high cheeks with strong cross ribs, a bed with low vibration and high rigidity is realized. Two precision ground vee slideways, reinforced by heat hardening and grinding, are an accurate guide for the carriage and headstock. The main drive motor is mounted to the rear of the bed.

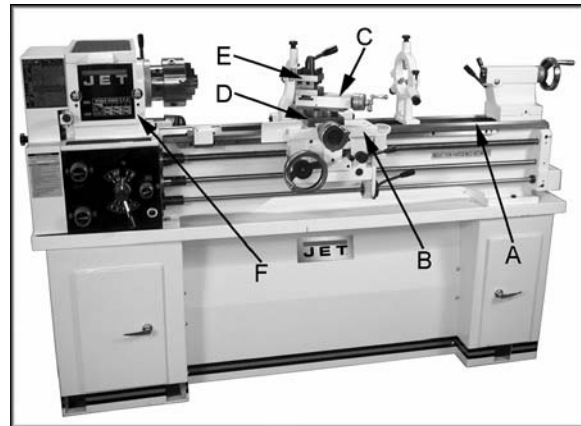

Figure 12

Carriage

The carriage (B, Fig. 12) is made from high quality cast iron. The sliding parts are smooth ground. The cross-slide is mounted on the carriage and moves on a dove-tailed slide which can be adjusted for play by means of the gibs.

The compound slide (C, Fig. 12), which is mounted on the cross slide (D, Fig. 12), can be rotated through 360°. The compound slide and the cross slide travel in a dovetail slide and have adjustable gibs. A four-way tool post (E, Fig. 12) is fitted on the compound slide.

Headstock

The headstock (F, Fig. 12) is cast from high grade, low vibration cast iron. It is mounted to the bed by four bolts with two adjusting bolts for alignment. In the head, the spindle is mounted on two precision taper roller bearings. The hollow spindle has Morse Taper #5 with a 1-3/8" bore.

Four Way Tool Post

The four-way tool (E, Fig. 12) post is mounted on the compound slide and allows a maximum of four tools to be mounted simultaneously. Remember to use a minimum of two clamping screws when installing a cutting tool.

Apron

The apron (A, Fig. 13) is mounted to the carriage. In the apron a half nut is fitted. The half nut gibs can be adjusted from the outside. The half nut is engaged by use of a lever. Quick travel of the apron is accomplished by means of a bed-mounted rack and pinion, operated by a hand wheel on the front of the apron.

Tailstock

The tailstock (B, Fig. 13) slides on a v-way and can be locked at any location by a clamping lever. The tailstock has a heavy-duty spindle with a Morse Taper #3.

Leadscrew and Feed Rod

The leadscrew (C Fig. 13) and feed rod (D, Fig. 10) are mounted on the front of the machine bed. They are connected to the gearbox at the left for automatic feed and lead. They are supported by bushings on both ends. Both are equipped with brass shear pins.

Gear Box

The gear box (E, Fig. 13) is made from high quality cast iron and is mounted to the left side of the machine bed.

Steady Rest

The steady rest (F, Fig. 13) serves as a support for shafts on the free tailstock end. The steady rest is mounted on the bedway and secured from below with a bolt, nut and locking plate. The sliding fingers require continuous lubrication at the contact points with the workpiece to prevent premature wear.

Follow Rest

The traveling follow rest (G, Fig. 13) is mounted on the saddle and follows the movement of the turning tool. Only two fingers are required as the turning tool takes the place of the third. The follow rest is used for turning operations on long, slender workpieces. It prevents flexing of the workpiece from the pressure of the cutting tool.

The sliding fingers are set similar to the steady rest, free of play, but not binding. The sliding fingers require continuous lubrication at the contact points with the workpiece to prevent premature wear.

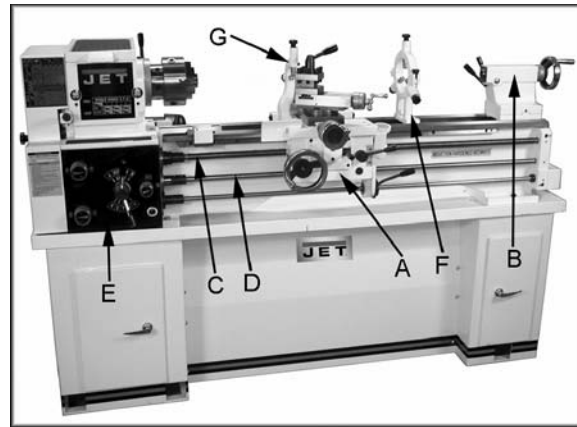

Figure 13

Controls

1. **Main On-Off Switch (A, Fig. 14)** – Power is off in the “0” position and on in the “I” position.
2. **Feed Direction Selector (B, Fig. 15)** – Arrows above the handle indicate saddle travel direction when the chuck is rotating in the forward direction or counter-clockwise as viewed from the front of the chuck.
3. **Feed Rod/Leadscrew Selector (C, Fig. 15)** – Use knob and lever to activate leadscrew and feed rod.
4. **Belt Tensioning Handle (D, Fig. 15)** – Pull forward to release tension on the drive belt. Push toward the rear to tension the belt.
5. **Feed Rate Selector (E, Fig. 15)** – Two knobs and two handles used to set desired feed, or lead rates.
6. **Forward/Reverse Lever (F, Fig. 16)** – Pull lever up for clockwise spindle rotation (reverse). Push lever down for counter-clockwise spindle rotation (forward). Neutral position is a center detent and the spindle remains idle.
7. **Compound Rest Lock (G, Fig. 16)** – Turn hex nut clockwise to lock and counter-clockwise to unlock.
8. **Compound Slide Lock (H, Fig. 16)** – Turn set screw clockwise to tighten and counter-clockwise to loosen.
9. **Cross Slide Lock (I, Fig. 16)** – Turn set screw clockwise, and tighten to lock. Turn counter-clockwise and loosen to unlock. **Caution:** cross slide lock screw must be unlocked before engaging automatic feeds or damage to the lathe may occur.
10. **Carriage Lock (J, Fig. 16)** – Turn hex socket cap screw clockwise and tighten to lock. Turn counter-clockwise and loosen to unlock. **Caution:** Carriage lock screw must be unlocked before engaging automatic feeds or damage to lathe may occur.

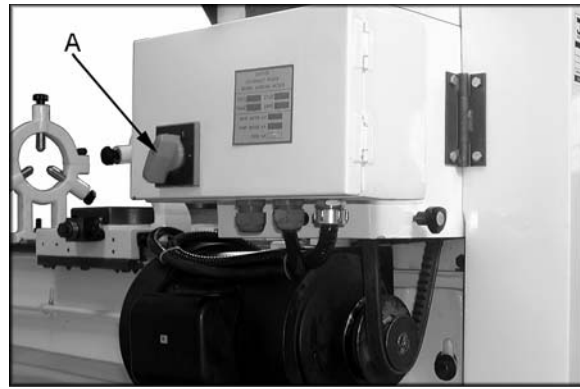

Figure 14

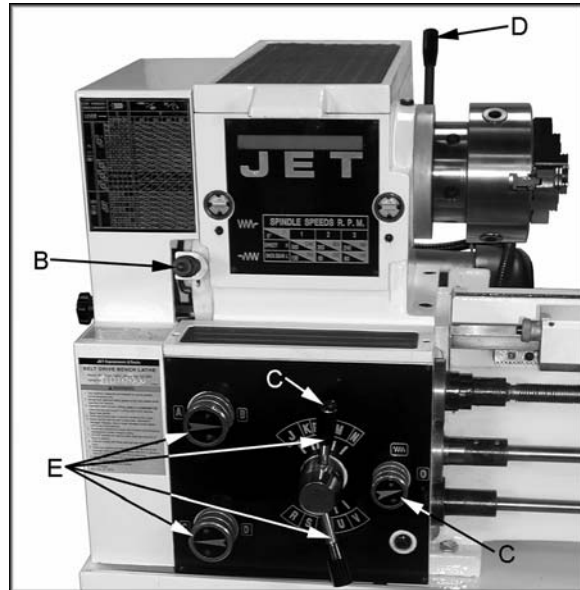

Figure 15

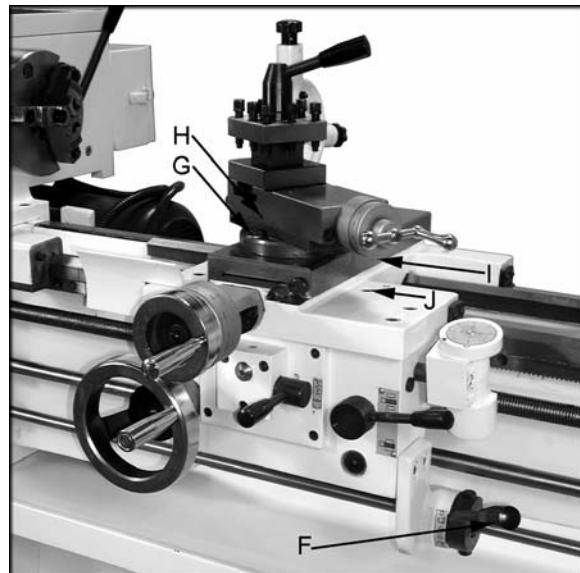

Figure 16

11. **Longitudinal Traverse Handwheel** (A, Fig. 17) – Rotate handwheel clockwise to move the apron assembly toward the tailstock (right). Rotate the wheel counter-clockwise to move the apron assembly toward the headstock (left).
12. **Feed Selector** (B, Fig. 17) – Push lever to the left and down to activate the crossfeed function. Pull lever to the right and up to activate the longitudinal function.
13. **Half Nut Engage Lever** (thread cutting) (C, Fig. 17) – Move the lever down to engage. Move the lever up to disengage.
14. **Cross Traverse Handwheel** (D, Fig. 17) – Clockwise rotation moves the cross slide toward the rear of the machine.
15. **Compound Rest Traverse Handwheel** (E, Fig. 17) – Rotate clockwise or counter-clockwise to move or position.
16. **Tool Post Clamping Lever** (F, Fig. 17) – Rotate counter-clockwise to loosen and clockwise to tighten. Rotate the tool post when the lever is unlocked.
17. **Threading Dial** (G, Fig. 17) – Engage by pushing into the leadscrew. Pull out to disengage. The dial indicator and chart will specify at which point a thread can be entered.
18. **Tailstock Quill Clamping Lever** (H, Fig. 18) – Lift up to lock the spindle. Push down to unlock.
19. **Tailstock Clamping Lever** (I, Fig. 18) – Lift up lever to lock. Push down lever to unlock.
20. **Tailstock Quill Traverse Handwheel** (J, Fig. 18) – Rotate clockwise to advance the quill. Rotate counter-clockwise to retract the quill.
21. **Tailstock Off-Set Adjustment** (K, Fig. 18) – Three set screws located on the tailstock base are used to off-set the tailstock for cutting tapers. Loosen lock screw on tailstock end. Loosen one side set screw (K, Fig. 18) while tightening the other until the amount of off-set is indicated on scale. Tighten lock screw.

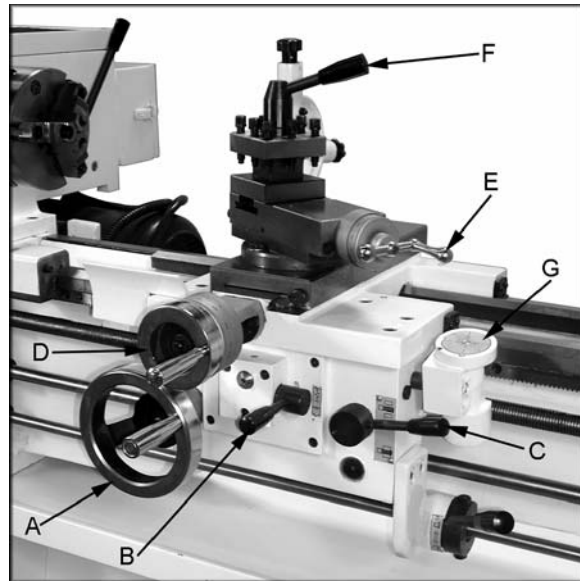

Figure 17

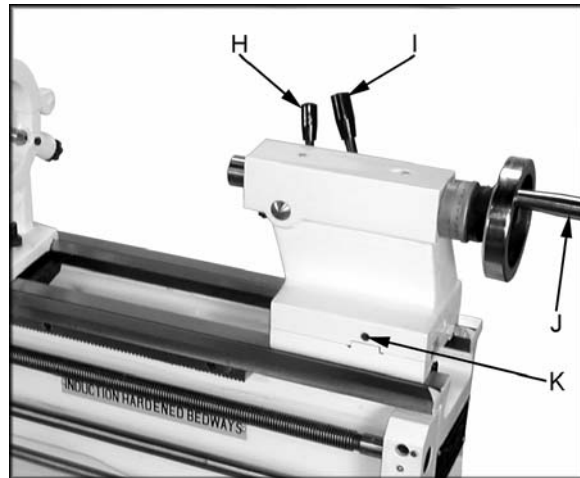

Figure 18

22. **High-Low Speed Selector** (A, Fig. 19) - Push toward the rear of the machine for the high-speed range and pull toward the front for the low speed range.
23. **Lock Pin for Back Gear** (B, Fig. 20) – For *high-speed* operation, pull out pin and turn pin 90° clockwise to engage back gear (B₁). To disengage the back gear for *low-speed* operation, pull the pin out, turn 90° counter-clockwise, and rotate the chuck until the pin seats.

CAUTION Engage back gear only for high-speed operation. Do not operate in low-speed range while back gear (B₁) is engaged. Failure to comply may result in gear damage.

Adjustments

Break-In Procedure

During manufacturing and testing, this lathe has been operated in the low R.P.M. range for three hours.

To allow time for the gears and bearings to break-in and run smoothly, do not run the lathe above 580 R.P.M. for the first six hours of operation and use.

Speed Selection

To change speeds, disconnect the lathe from the power source and remove the tension by pulling handle (C, Fig. 20) forward. Move the belts (D, Fig. 20) to the desired location according to the speed selection chart (E, Fig. 21). Tension the belts by moving the handle towards the rear.

Feed and Thread Selection

1. Reference the feed and thread tables (F, Fig. 21).
2. Move levers and knobs (G, Fig. 21) to the appropriate position.

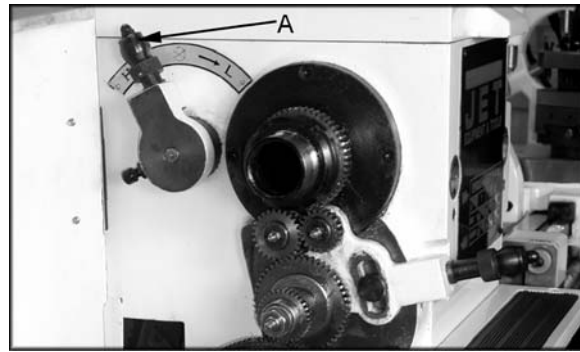

Figure 19



Figure 20

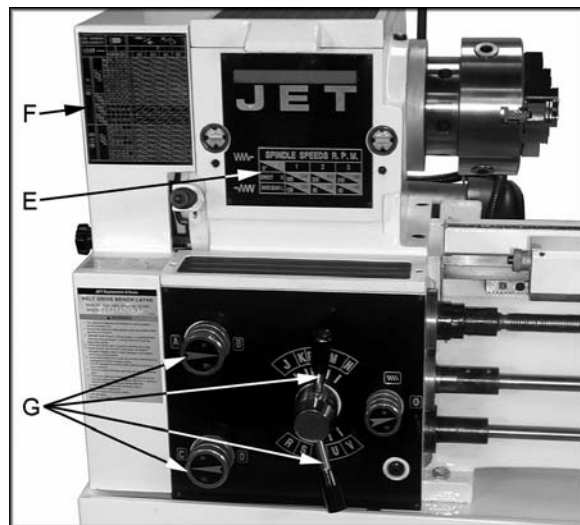

Figure 21

Change Gear Replacement

Note: The 32T x 127T x 48T gears are installed in the end gear compartment when delivered from the factory. This combination will cover most inch feeds and threads under normal circumstances. The additional gears found in the toolbox are used for some metric threads and feeds.

1. Disconnect the machine from the power source.
2. Open the end cover on the left end of the headstock.
3. Loosen the socket head cap screw (A, Fig. 22) and hex nuts (B, Fig. 22). Move the quadrant out of the way.
4. Change gears (C, Fig. 22) to match the feed and thread chart.
5. Thoroughly clean and install new gears.
6. Move the quadrant so the large gear meshes with the smaller gears and tighten to secure in place. Note: Make sure there is backlash of 0.002" – 0.003" between gears. Setting the gears too tight will cause excessive noise and wear.
7. Close the cover and connect the machine to the power source.

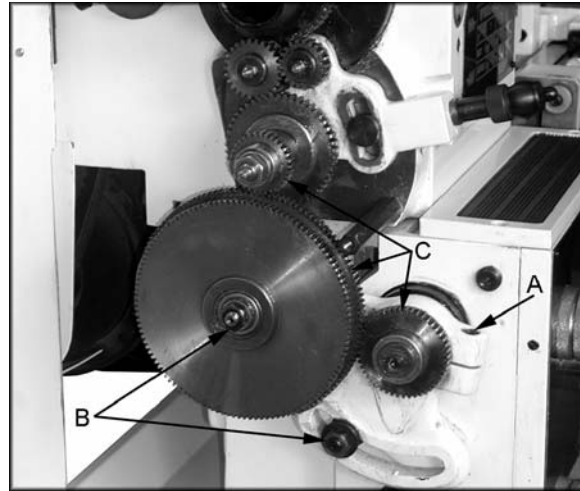

Figure 22

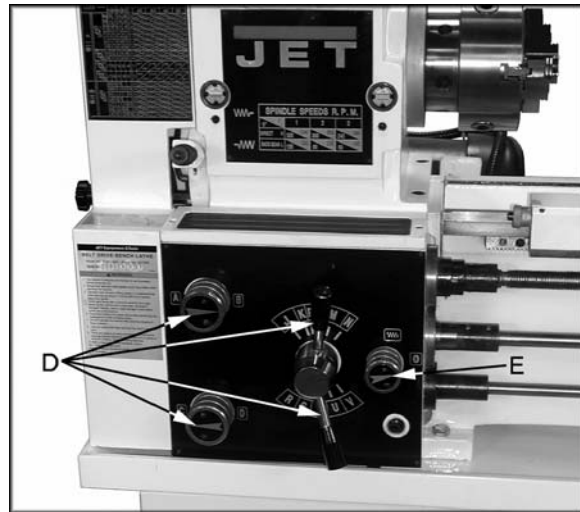

Figure 23

Thread Cutting

1. Set feed rate selectors (D, Fig. 23) in proper position for the correct feed rate of the thread to be cut.
2. Move knob (E, Fig. 23) to the "0" position to disengage the feed rod.
3. Engage the half nut lever (F, Fig. 24).
4. The half nut lever and threading dial are used to thread in the conventional manner. The thread dial chart specifies at which point a thread can be entered using the threading dial.
5. To cut metric threads, the half nuts must be left continually engaged once the start point has been selected and the half nut is initially engaged (thread dial cannot be used).

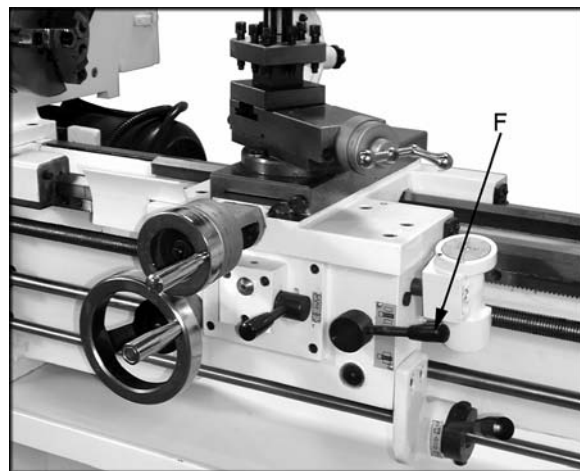





Figure 24

Thread and Feed Chart

LEAD SCREW 8TPI CROSS SCREW 8TPI													
LEVER →		0				P							
		ADBDACBC				AD BD AC BC							
IN T/1"		③② 127 ②① ④⑧	NU	3½	7	14	28	U	.0278 .0096	.0139 .0048	.0070 .0024	.0035 .0012	
			NS	4	8	16	32	S	.0244 .0084	.0122 .0042	.0061 .0021	.0030 .0010	
			KU	5¼	10½	21	42	U	.0278 .0096	.0139 .0048	.0070 .0024	.0035 .0012	
			KT	5½	11	22	44	T	.0266 .0091	.0133 .0046	.0066 .0023	.0033 .0011	
			LT	6	12	24	48	T	.0266 .0091	.0133 .0046	.0066 .0023	.0033 .0011	
			KV	9	18	36	72	V	.0162 .0056	.0081 .0028	.0041 .0014	.0020 .0007	
		④④ 127 ②① ③③	KR	10	20	40	80	R	.0146 .0050	.0073 .0025	.0037 .0013	.0018 .0006	
			KV	4½	9	18	36	V	.0325 .0112	.0162 .0055	.0081 .0028	.0041 .0014	
			KR	5	10	20	40	R	.0292 .0100	.0146 .0049	.0073 .0025	.0036 .0012	
			③② 127 ②① ④⑥	LT	5¾	11½	23	46	T	.0277 .0095	.0139 .0048	.0069 .0024	.0035 .0012
				LT	6½	13	26	52	T	.0245 .0084	.0122 .0042	.0061 .0021	.0031 .0011
			MM MM		④⑧ 127 ②① ④⑧	MM	3.5	1.75			V	.0230 .0079	.0115 .0040
KR	3.6	1.8				0.9	0.45	R	.0207 .0071	.0104 .0036	.0052 .0018	.0026 .0009	
KV	4	2				1	0.5	V	.0230 .0079	.0115 .0040	.0058 .0020	.0029 .0010	
LS	5.5	2.75						S	.0345 .0119	.0173 .0059	.0086 .0030	.0043 .0015	
LT	6	3				1.5	0.75	T	.0374 .0130	.0187 .0065	.0093 .0032	.0047 .0016	
NS	9	4.5				2.25		S	.0345 .0119	.0173 .0059	.0086 .0030	.0043 .0015	
JS	10	5				2.5	1.25	S	.0345 .0119	.0173 .0059	.0086 .0030	.0043 .0015	

Automatic Feed Operation and Feed Changes

1. Move forward/reverse selector (A, Fig. 25) up or down depending on desired direction.
2. Set the selector handle (B, Fig. 26) to the "P" position and turn knob (C, Fig. 26) counter-clockwise so the arrow is pointing up to start the feed rod rotating.

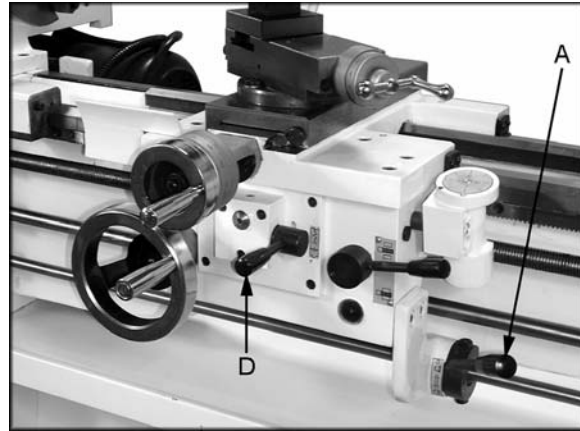

Figure 25

Powered Carriage Travel

Push lever (D, Fig. 25) to the left and down to engage crossfeed. Pull lever to the right and up to engage longitudinal feed.

Saddle Adjustment

1. Loosen four hex nuts (E, Fig. 27) found on the bottom rear of the cross slide.
2. Turn each of the four set screws (F, Fig. 27) equally with a hex wrench until a slight resistance is felt. Do not over tighten.
3. Move the carriage with the hand wheel and determine if drag is to your preference. Re-adjust the setscrews as necessary to achieve the desired drag.
4. Hold socket set screw firmly with a hex wrench and tighten hex nut to lock in place.
5. Move the carriage again and adjust if necessary. **Note:** Over adjustment will cause excessive premature wear of the gibs.

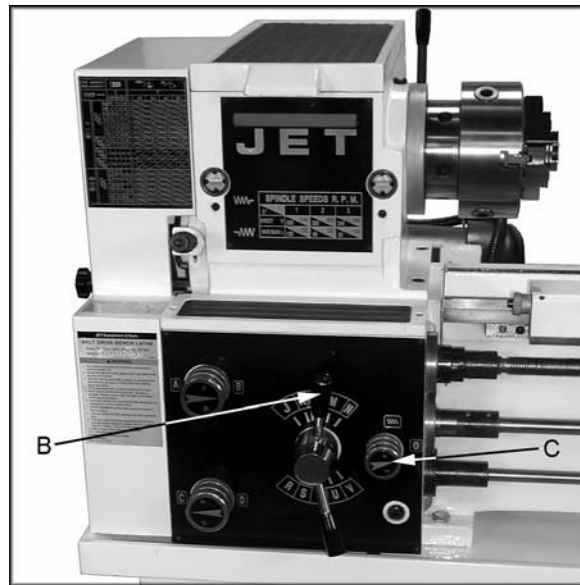

Figure 26

Cross Slide Adjustment

If the cross slide is too loose, follow procedure below to tighten:

1. Loosen the rear gib screw (G, Fig. 27) approximately one turn.
2. Tighten front gib screw a quarter turn. Turn the cross slide handwheel to see if the cross slide is still loose. If it is still loose, tighten the front screw a bit more and try again.
3. When cross slide is properly adjusted, snug rear gib screw. Do not over tighten. This will cause premature wear on the gib and mating parts.

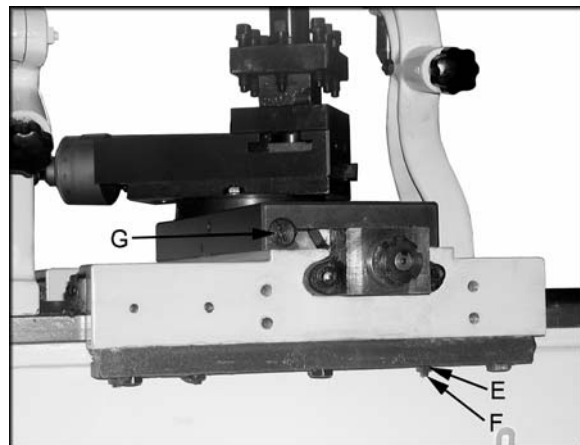

Figure 27

Compound Rest Adjustment

Follow the same procedure as for the cross slide adjustment.

Tailstock Adjustment

If the handle will not lock the tailstock securely, use the following procedure:

1. Lower handle to the unlocked position.
2. Slide tailstock to an area that will allow you to reach under the tailstock.
3. Tighten tailstock clamping nut 1/4 turn, and re-test for proper locking. Repeat as necessary.

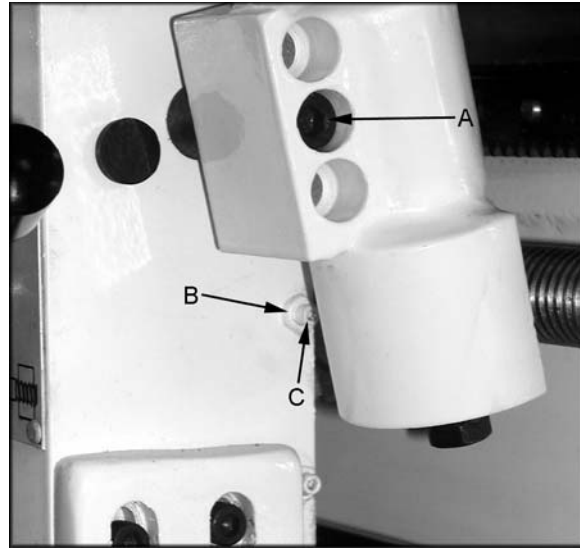

Figure 28

Half Nut Gib Adjustment

1. Remove the thread dial assembly by unscrewing the screw (A, Fig. 28).
2. Loosen three hex nuts (B, Fig. 28) found on the side of apron, and turn three set screws (C, Fig.28) equally with a hex wrench.
3. Adjust properly for wear and play. Hold socket set screw firmly with a hex wrench and tighten hex nut to lock in place. **Note:** Over adjustment will cause excessive premature wear on gib and mating parts.

Headstock Alignment

The headstock has been aligned at the factory and should not require adjustment. However, if adjustment is deemed necessary, follow the procedure below to align the headstock.

1. Using an engineer's precision level on the bedways, make sure the lathe is level side to side and front to back. If the lathe is not level, correct to a level condition before proceeding. Re-test alignment if any leveling adjustments were made.
2. From steel bar stock of approximately two inches in diameter, cut a piece approximately eight inches long.
3. Place two inches of bar stock into chuck and tighten chuck. Do not use the tailstock or center to support the other end.
4. Set up and cut along five inches of the bar stock.

5. Using a micrometer, measure the bar stock next to the chuck and at the end. The measurement should be the same.
6. If the measurements are not the same and adjustment is required, loosen the four bolts that hold the headstock to the bed. Do not loosen completely; some drag should remain.
7. Loosen two hex nuts found on the two adjusting bolts located on the backside of headstock just above the motor mount bracket. Adjust the bolts for alignment and tighten hex nuts. Tighten the headstock bolts and make another cut. Keep adjusting screws after each cut until the bar stock measurements are the same. Tighten all headstock bolts and jam nuts on adjusting screws.

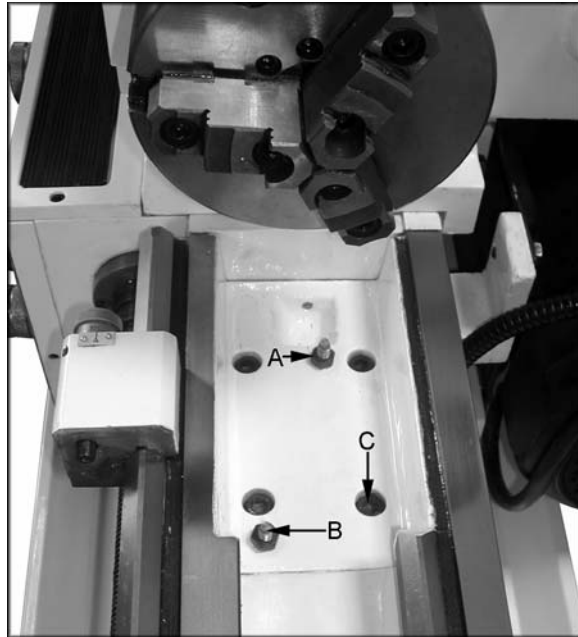

Figure 29

Removing Gap Bridge

1. Using an open end wrench, tighten the two hex nuts (A, Fig. 29). This will cause the taper pins (B, Fig. 29) to release. Remove the taper pins.
2. Remove the four hex socket cap screws (C, Fig. 29) with a hex key wrench.
3. Gap bridge can now be removed.

Installing Gap Bridge

1. Clean the bottom and the ends of the gap bridge thoroughly.
2. Set gap bridge in place and align.
3. Remove nuts (A, Fig. 29) from the taper pins (B, Fig. 29).
4. Slide taper pins in their respective holes and seat using a mallet. Install nuts on the taper pins finger tight.
5. Install four socket head cap screws (C, Fig. 29) and tighten securely.



Model No.:	Stock No.:
Serial No.:	
Purchased From:	
Date Purchased:	Date Installed:

Parts List and Electrical Diagrams

For Lathe models BDB-1340A, GHB-1340A, GHB-1440A



(GHB-1340A shown with optional stand 321443AK)

For GHB-1340A/1440A Operating Instructions, see document M-321357A-1
For BDB-1340A Operating Instructions, see document M-321360A

JET

427 New Sanford Road
LaVergne, Tennessee 37086
Ph.: 800-274-6848
www.jettools.com

Part No. M-321357A
Revision I 11/2014
Copyright © 2014 JET

Table of contents

Section	Page
Table of contents.....	2
Replacement parts.....	3
1.0 BDB-1340A Headstock Assembly I – Exploded View.....	4
1.1 BDB-1340A Headstock Assembly I – Parts List.....	5
2.1 BDB-1340A Headstock Assembly II – Exploded View.....	6
2.2 BDB-1340A Headstock Assembly II – Parts List.....	7
3.1 BDB-1340A Headstock Assembly III – Exploded View.....	8
3.2 BDB-1340A Headstock Assembly III – Parts List.....	9
4.1 GHB-1340A/1440A Headstock Assembly I – Exploded View.....	10
4.2 GHB-1340A/1440A Headstock Assembly I – Parts List.....	11
5.1 GHB-1340A/1440A Headstock Assembly II – Exploded View.....	13
5.2 GHB-1340A/1440A Headstock Assembly II – Parts List.....	14
6.1 GHB-1340A/1440A Headstock Assembly III – Exploded View.....	15
6.2 GHB-1340A/1440A Headstock Assembly III – Parts List.....	16
7.1 Bed Assembly I – Exploded View.....	17
7.2 Bed Assembly I – Parts List.....	18
8.1 Bed Assembly II – Exploded View.....	20
8.2 Bed Assembly II – Parts List.....	21
9.1 Gear Assembly I – Exploded View.....	22
9.2 Gear Assembly I – Parts List.....	23
10.1 Gear Assembly II – Exploded View.....	24
10.2 Gear Assembly II – Parts List.....	25
11.1 Gear Assembly III – Exploded View.....	26
11.2 Gear Assembly III – Parts List.....	27
12.1 Apron Assembly I – Exploded View.....	28
12.2 Apron Assembly I – Parts List.....	29
13.1 Apron Assembly II – Exploded View.....	30
13.2 Apron Assembly II – Parts List.....	31
14.1 Apron Assembly III – Exploded View.....	32
14.2 Apron Assembly III – Parts List.....	32
15.1 Micro Carriage Stop Assembly – Exploded View.....	33
15.2 Micro Carriage Stop Assembly – Parts List.....	33
16.1 Top Slide, Tool Post, Saddle, and Cross Slide I – Exploded View.....	34
16.2 Top Slide, Tool Post, Saddle, and Cross Slide I – Parts List.....	35
17.1 Top Slide, Tool Post, Saddle, and Cross Slide II – Exploded View.....	36
17.2 Top Slide, Tool Post, Saddle, and Cross Slide II – Parts List.....	37
18.1 Tailstock Assembly I – Exploded View.....	38
18.2 Tailstock Assembly I – Parts List.....	39
19.1 Tailstock Assembly II – Exploded View.....	40
19.2 Tailstock Assembly II – Parts List.....	40
20.1 Follow Rest – Exploded View.....	41
20.2 Follow Rest – Parts List.....	41
21.1 Steady Rest – Exploded View.....	42
21.2 Steady Rest – Parts List.....	43
22.1 GHB-1340A/1440A Chuck Guard Assembly – Exploded View.....	44
22.2 GHB-1340A/1440A Chuck Guard Assembly – Parts List.....	44
23.0 Additional Parts (Not Shown).....	45
24.0 Additional Electrical Components (Not Shown).....	45
25.1 Electrical Schematic – GHB-1340A/1440A.....	46
25.2 Electrical Schematic Parts List – GHB-1340A/1440A.....	46
26.1 Electrical Schematic – BDB-1340A.....	47
26.2 Electrical Schematic Parts List – BDB-1340A.....	47
27.0 GHB-1340A/1440A Wiring Photo.....	48
28.0 BDB-1340A Wiring Photo.....	48

Replacement parts

To order parts or reach our service department, call 1-800-274-6848 Monday through Friday (see our website for business hours, www.jettools.com). Having the Model Number and Serial Number of your machine available when you call will allow us to serve you quickly and accurately.

1.0 BDB-1340A Headstock Assembly I – Exploded View

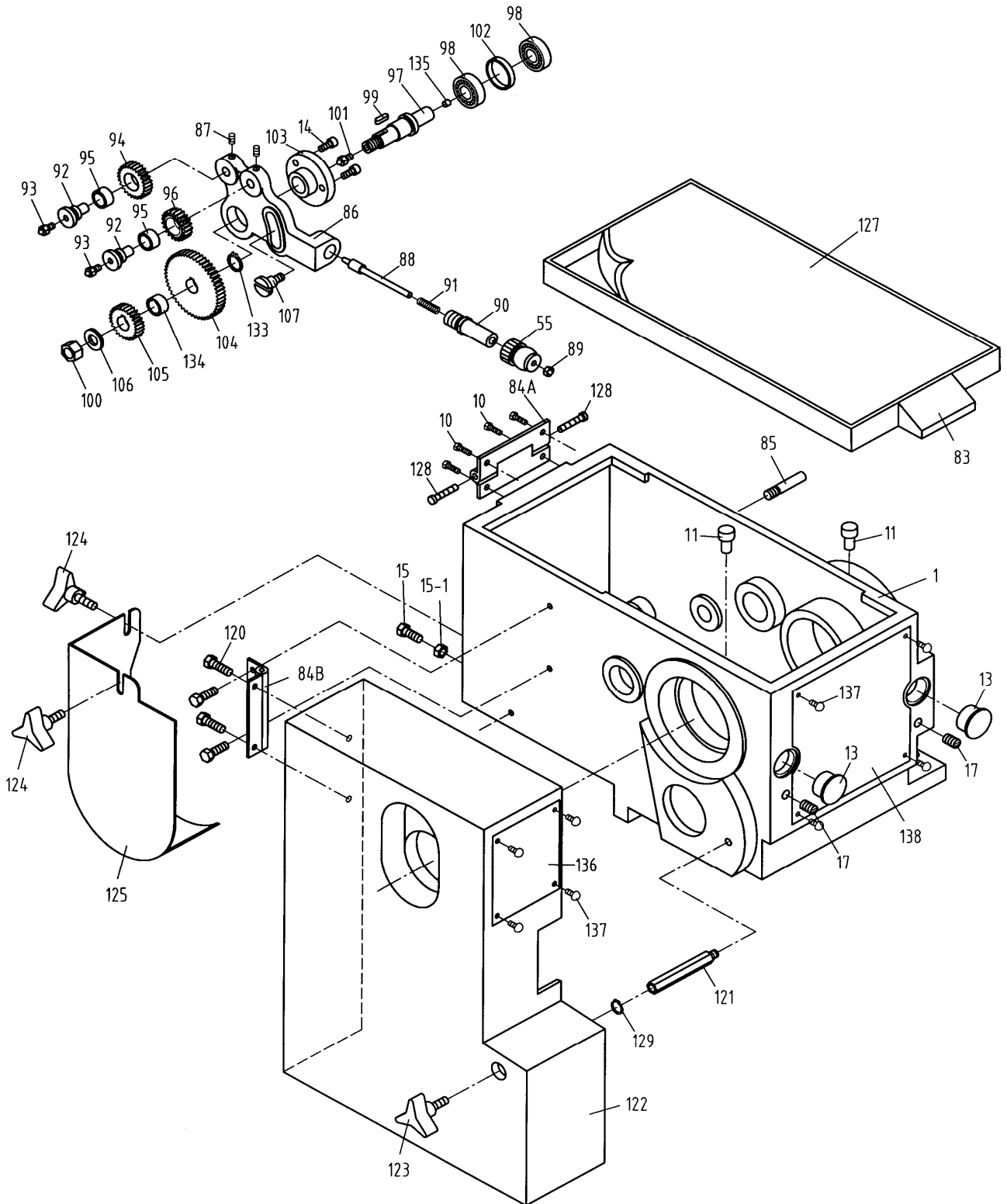

1.1 BDB-1340A Headstock Assembly I – Parts List

Index No	Part No	Description	Size	Qty
1	04101B	Headstock Casting		1
10	TS-1482021	Hex Socket Cap Screw	M6 x 12	4
11	04501A	Inlet Plug		2
13	BDB1340-H13	Oil Sight Glass		2
14	TS-1503031	Hex Socket Cap Screw	M6 x 12	3
15	TS-1490081	Hex Cap Bolt	M8 x 45	2
15-1	TS-1540061	Nut	M8	2
17	BDB1340-H17	Screw	1/8"	2
55	04733B	Knob		1
83	04310	Cover		1
84A	04723A	Cover Hinge		1
84B	04723B	End Cover Hinge		1
85	04705	Strut		1
86	BDB1340A-02118A	Arm		1
87	TS-1523031	Set Screw	M6 x 10	2
88	04725B	Plunger		1
89	BDB1340-H89	Cap Nut		1
90	04734B	Spring Sleeve		1
91	BDB1340-H91	Spring	1x9x50	1
92	04721	Idle Shaft		2
93	BDB1340-H93	Oil Nipple		2
94	04719	Gear	1.5m26T	1
95	04303	Bushing		2
96	04720	Gear	1.5m21T	1
97	BDB1340A-02717A	Output Shaft		1
98	BB-6202ZR	Ball Bearing	6202ZR	2
99	BDB1340A-H99	Key	5 x 5 x 50	1
100	TS-1540081	Hex Nut	M12	1
101	BDB1340-H93	Oil Nipple		1
102	04716	Spacer		1
103	04119A	Flange		1
104	BDB1340A-02718A	Gear	1.5m50T	1
105	GH1340A-05735	Gear	1.25m32T	1
	32A5726A	Gear	1.25m42T	1
	BDB1340A-32A5726A	Gear	1.25m44T	1
106	BDB1340-H106	Washer		1
107	04714	Bolt		1
120	TS-1482021	Cap Screw	M6 x 12	4
121	BDB1340A-02722A	Stud		1
122	BDB1340A-02305A	End Cover		1
123	BDB1340-H123	Knob		1
124	BDB1340-H124	Knob		2
125	04724	Cover		1
127	BDB1340-H127	Rubber Mat		1
128	TS-1503081	Hex Socket Cap Screw	M6 x 35	2
129	BDB1340-H129	C-Clip	8	1
133	BDB1340A-H133	C-clip for Shaft	19	1
134	BDB1340A-02124	Spacer		1
135	BDB1340A-H135	Plug	5	1
136	BDB1340A-H136	Sign Plate		1
137	BDB1340A-H137	Half Round Cap Screw	M3x50	8
138	BDB1340A-H138	Sign Plate		1

2.1 BDB-1340A Headstock Assembly II – Exploded View

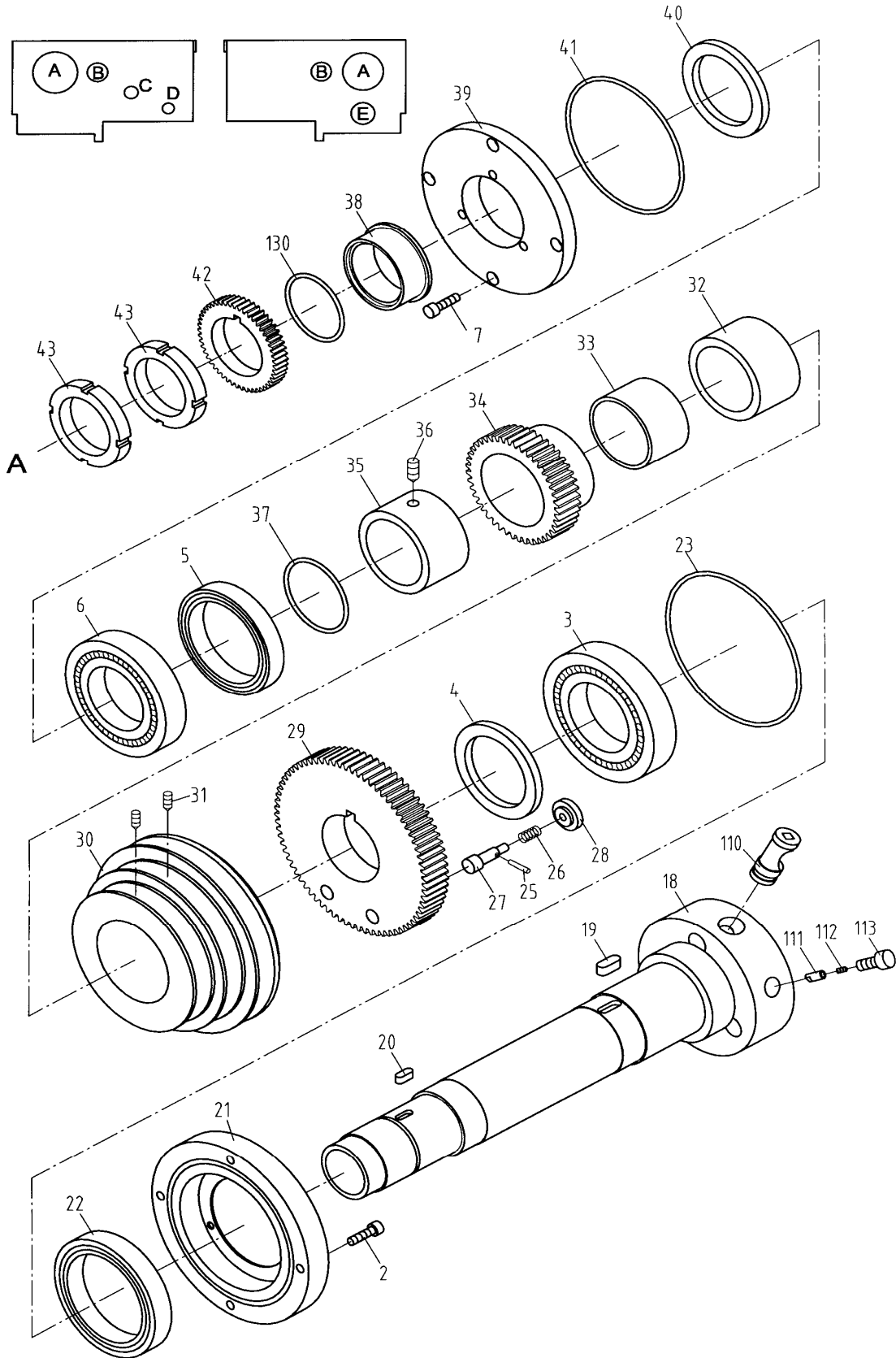

2.2 BDB-1340A Headstock Assembly II – Parts List

Index No	Part No	Description	Size	Qty
2	TS-1503051	Socket Set Screw	M8 x 10	4
3	BB-30212	Taper Roller Bearing	60 x 110 x 22	1
4	BDB1340-H4	Oil Seal	PG60 x 80 x 12	1
5	OS-709012	Oil Seal	SG70 x 90 x 12	1
6	BB-30211	Taper Roller Bearing	55 x 100 x 21	1
7	TS-1503041	Hex Socket Cap Screw	M6 x 16	4
18	04701	Spindle	D1-4	1
19	BDB1340-H19	Key	8 x 7 x 18	1
20	BDB1340-H20	Key	6 x 6 x 16	1
21	04102	Bearing Cover (front)		1
22	BDB1340-H22	Oil Seal	75 x 100 x 12	1
23	BDB1340-H23	O-Ring	125 x 3.1	1
25	BDB1340-H25	Shaft Pin	3 x 18	1
26	BDB1340-H26	Spring	0.8 x 11 x 18	1
27	04703	Pin		1
28	04702	Nut		1
29	04117A	Gear	2m74T	1
30	04116	Pulley		1
31	TS-1523031	Set Screw	M6 x 10	2
32	04302	Bushing		1
33	04301	Bushing		1
34	04115	Gear	2m44T	1
35	04114	Spacer		1
36	TS-1524021	Set Screw	M8 x 6	1
37	BDB1340-H37	O-Ring	60 x 3.1	1
38	04112A	Spacer		1
39	04113	Bearing Cover (rear)		1
40	BDB1340-H40	Oil Seal	W60 x 80 x 8	1
41	BDB1340-H41	O-Ring	110 x 3.1	1
42	04713	Gear	1.5m50T	1
43	04743	Locking Nut		2
110	04729	Cam		3
111	04741	Pin		3
112	BDB1340-H112	Spring	0.6 x 4 x 16	3
113	TS-1504041	Hex Socket Cap Screw	M8 x 18	3
130	BDB1340-H130	O-Ring	55 x 3.1	1

3.1 BDB-1340A Headstock Assembly III – Exploded View

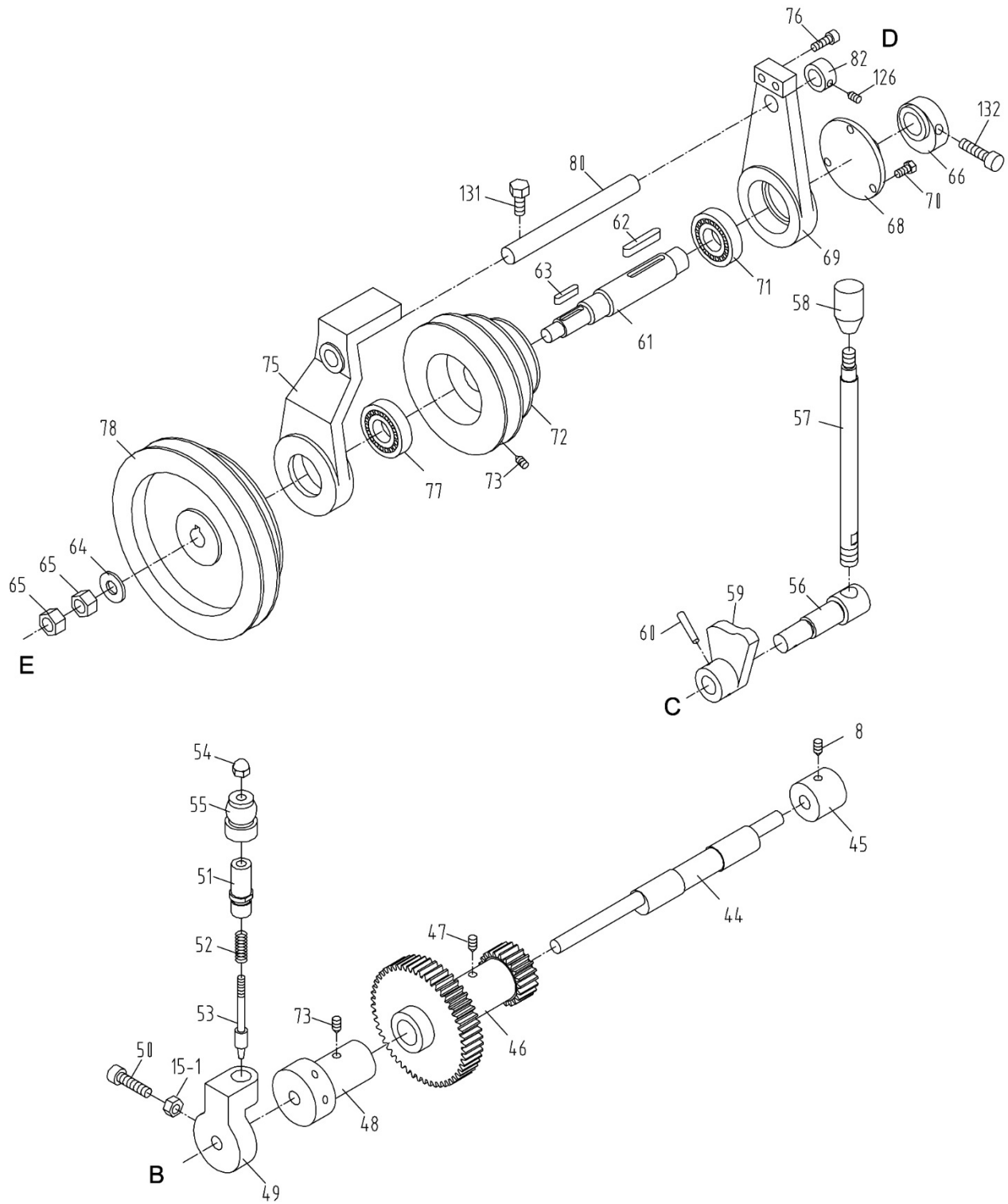

3.2 BDB-1340A Headstock Assembly III – Parts List

Index No	Part No	Description	Size	Qty
8	TS-1524021	Set Screw	M8 x 10	1
15-1	TS-1540061	Nut	M8	1
44	04704	Eccentric Shaft		1
45	04103A	Bushing		1
46	04109A	Gear	2m52T, 2m22T	1
47	TS-1523011	Set Screw	M6 x 6	1
48	04111A	Bushing		1
49	04110	Moving Arm		1
50	TS-1504071	Hex Socket Cap Screw	M8 x 35	1
51	04726	Sleeve		1
52	BDB1340-H52	Spring	1 x 9 x 40	1
53	04725	Shaft		1
54	BDB1340-H54	Cap Nut	M6	1
55	04733B	Knob		1
56	04706	Shaft		1
57	04707	Handle		1
58	BDB1340-H58	Knob		1
59	04104A	Cam		1
60	BDB1340-H60	Spring Pin	5 x 30	1
61	04712	Input Shaft		1
62	BDB1340-H62	Key	6 x 6 x 40	1
63	BDB1340-H63	Key	5 x 5 x 25	1
64	TS-1550081	Washer	M12	1
65	TS-1540081	Hex Nut	M12	2
66	04708	Cam		1
68	04709	Strut		1
69	04105A	Swing Arm		1
70	TS-1482021	Hex Socket Cap Screw	M6 x 12	3
71	BB-6204ZR	Ball Bearing	6204ZR	1
72	04107	Pulley		1
73	TS-1524021	Set Screw	M8 x 8	2
75	04106A	Swing Arm		1
76	TS-1503051	Hex Socket Cap Screw	M6 x 20	2
77	BB-6204	Ball Bearing	6204	1
78	BDB1340A-04108	Pulley		1
80	04711	Shaft		1
82	04710	Spacer		1
126	TS-1523011	Set Screw	M6 x 6	1
131	TS-1490041	Hex Cap Bolt	M8 x 25	1
132	TS-1504041	Hex Socket Cap Screw	M8 x 20	1
	BDB1340A-02311	Nameplate (not shown)		1
	BDB1340A-02304A	Nameplate (not shown)		1
	04308	Nameplate (not shown)		1
	VB-B32	V-Belt (not shown)	B32	1
	VB-B33	V-Belt (not shown)	B33	1

4.1 GHB-1340A/1440A Headstock Assembly I – Exploded View

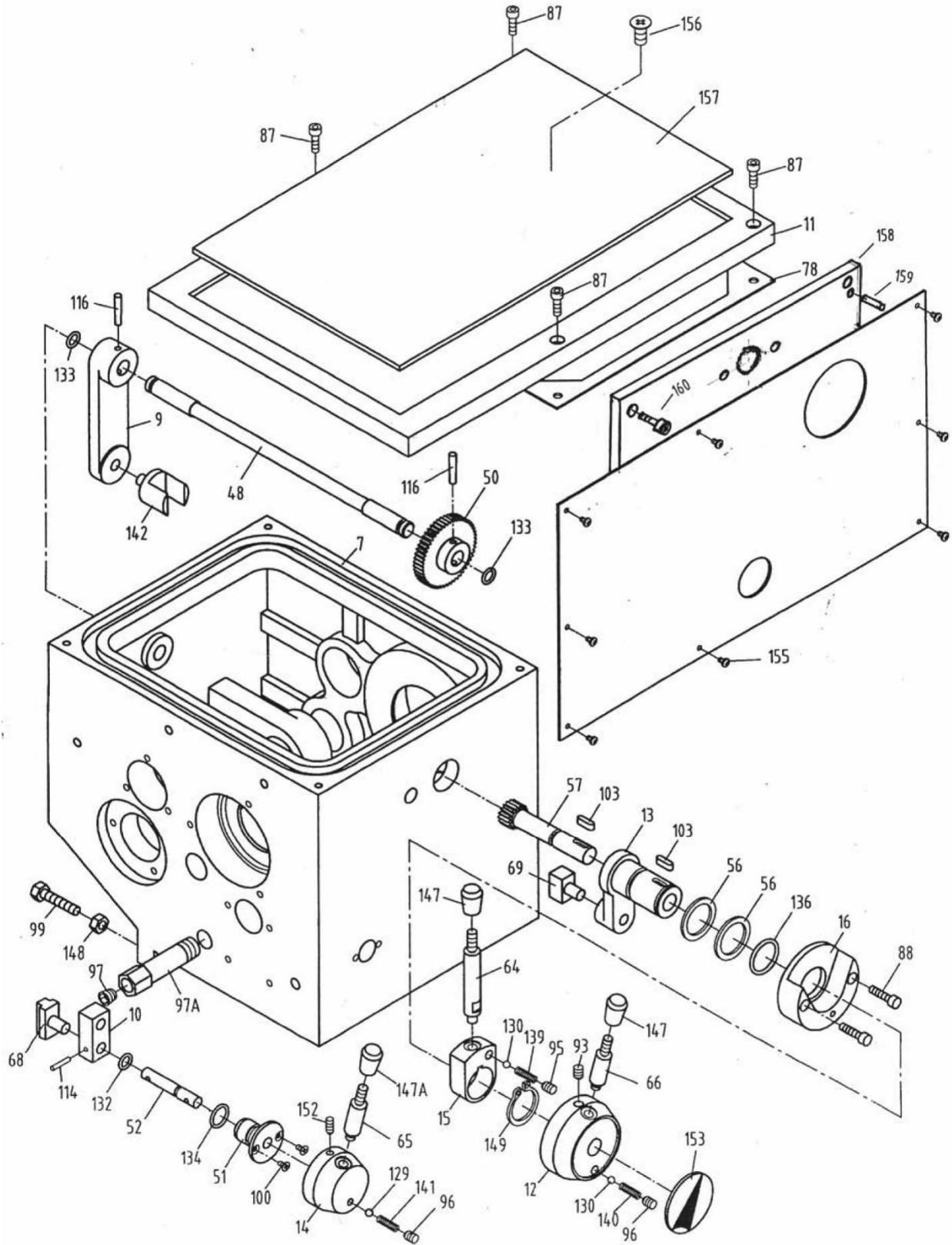

4.2 GHB-1340A/1440A Headstock Assembly I – Parts List

Index No	Part No	Description	Size	Qty
7	GHB1340A-02101	Gear Box Main Casting (GHB-1340A only)		1
	GHB1440A-02101	Gear Box Main Casting (GHB-1440A only)		1
9	04109	Shift Lever		1
10	04111	Shaft Housing		1
11	GHB1340A-02102	Cover (GHB-1340A only)		1
	GHB1440A-02102	Cover (GHB-1440A only)		1
12	GHB1340A-04117	Handle Hub		1
13	04121	Shaft Collar (GHB-1340A only)		1
	GHB1440A-02112	Shaft Collar (GHB-1440A only)		1
14	GHB1340A-04120	Handle Hub		1
15	GHB1340A-04119	Handle Block		1
16	GHB1340A-04118	Hub		1
48	04232	Shaft		1
50	04234	Gear	1.25m51T	1
51	04235	Collar (GHB-1340A only)		1
	GHB1440A-02709	Collar (GHB-1440A only)		1
52	04250	Shaft (GHB-1340A only)		1
	GHB1440A-02708	Shaft (GHB-1440A only)		1
56	04240	Washer		2
57	04241	Gear Shaft (GHB-1340A only)	1.25m17T	1
	GHB1440A-02716	Gear Shaft (GHB-1440A only)	1.25m17T	1
64	GHB1340A-04248	Handle		1
65	GHB1340A-04248-1	Handle		1
66	GHB1340A-04249	Handle		1
68	04402	Shift Fork		1
69	04403	Shift Fork		1
78	GHB1340-4506	Gasket (GHB-1340A only)		1
	GHB1440A-02507	Gasket (GHB-1440A only)		1
87	TS-1503051	Hex Socket Cap Screw	M6 x 20	4
88	TS-1503061	Hex Socket Cap Screw	M6 x 25	2
93	TS-1523061	Set Screw	M6 x 18	1
95	TS-1524011	Set Screw	M8 x 8	1
96	TS-1523041	Set Screw	M6 x 12	2
97	GHB1340A-97	Plug	Z1/4	1
97A	GHB1340A-97A	Oil Drain Plug		1
99	TS-1490071	Hex Cap Screw	M8 x 40	2
100	GHB1340-100	Screw	M4 x 8	4
103	GHB1340-103	Key	5 x 15	2
114	GHB1340-114	Pin	4 x 18	1
116	GHB1340-116	Pin	5 x 30	2
129	SB-5MM	Steel Ball	5	1
130	SB-6MM	Steel Ball	6	2
132	GHB1340-132	O-Ring	10 x 1.9	1
133	GHB1340-133	O-Ring	14 x 2.4	2
134	GHB1340-134	O-Ring	20 x 2.4	2
136	GHB1340-136	O-Ring	30 x 3.1	1
139	GHB1340-139	Spring	1 x 6 x 7	1
140	GHB1340-140	Spring	1 x 6 x 20	1
141	GHB1340-141	Spring	0.9 x 4.4 x 20	1
142	04235A	Shift Fork		1
147	GHB1340-147	Knob	M8 x 40	2
147A	GHB1340-147A	Knob		1
148	TS-1540061	Nut	M8	2
149	GHB1340-120	C-Clip	30	1
152	TS-1523041	Set Screw	M6 x 12	1
153	GHB1340A-153	Round Sign Plate		1
154	GHB1340A-02301	Label (GHB-1340A only)		1
	GHB1440A-02301	Label (GHB-1440A only)		1
155	GHB1340A-155	Screw	M3 x 5	8
156	GHB1340A-156	Screw	M10 x 18	1

Index No	Part No	Description	Size	Qty
157	GHB1340A-02502	Rubber Mat (GHB-1340A only)		1
	GHB1440A-02503	Rubber Mat (GHB-1440A only)		1
158	GHB1440A-02102	Headstock Side Board (GHB-1440A only)		1
159	GB117	Pin	5 x 20	2
160	TS-1503041	Hex Socket Cap Screw	M6 x 16	4
	GHB1340A-160	Oil Sight Glass (not shown) (GHB-1340A serial #10052363A and lower)		1
	GHB1340A-160M	Oil Sight Glass (not shown) (GHB-1340A serial #10102364A and higher)	M27x1.5	1

5.1 GHB-1340A/1440A Headstock Assembly II – Exploded View

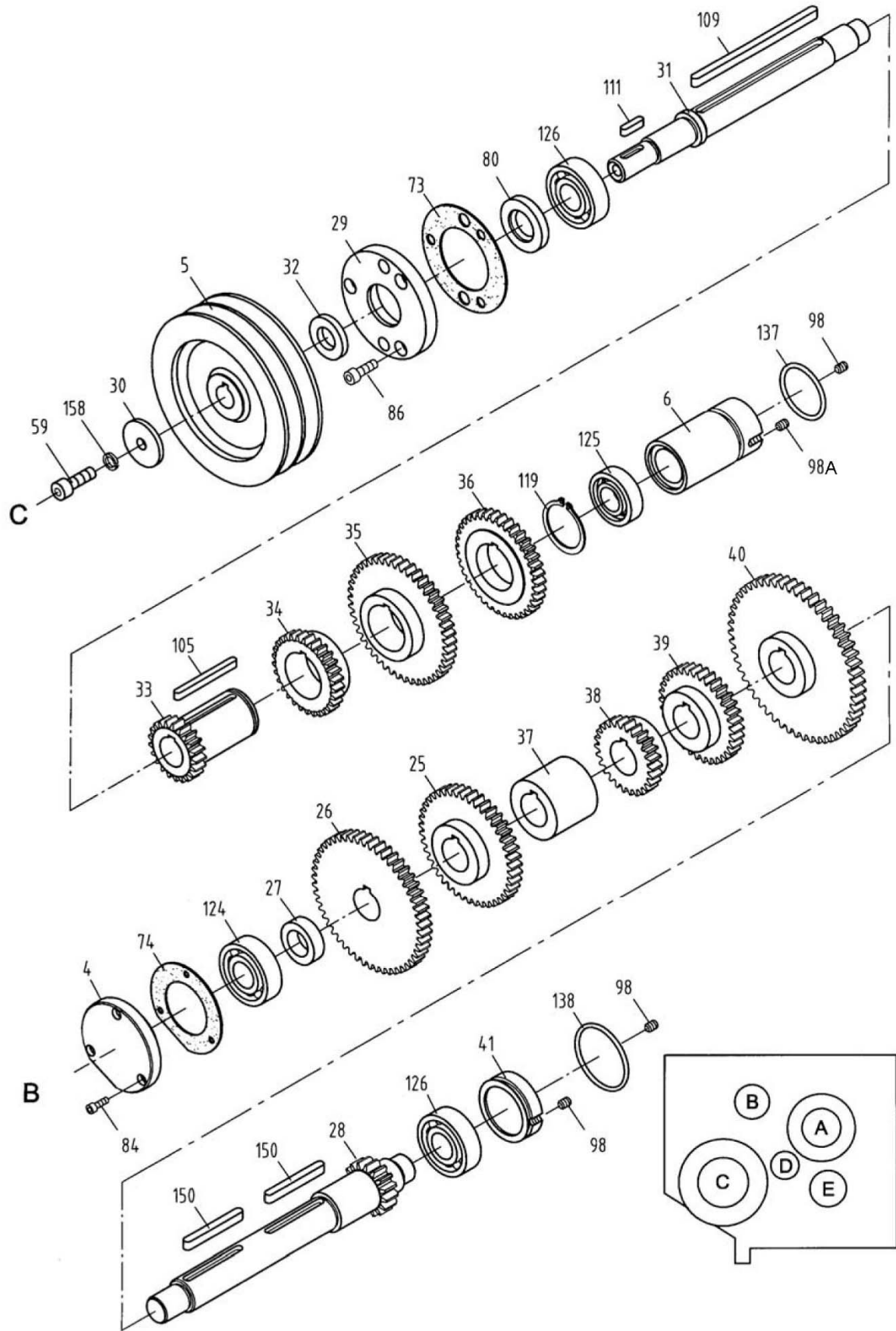

5.2 GHB-1340A/1440A Headstock Assembly II – Parts List

Index No	Part No	Description	Size	Qty
4	04104Z	Rear Cover		1
5	04105	Pulley		1
6	GHB1340-4106	Plug		1
25	04209	Gear	2m43T	1
26	GHB1340-4210	Gear	2m51T	1
27	04211	Spacer		1
28	04212	Gear Shaft	2.25m16T	1
29	04213	Cover (s/n 0207ZN3348 and lower)		1
	04213A	Cover (s/n 0207ZN3349 and higher)		1
30	04214	Washer		1
31	04215	Shaft		1
32	04216	Washer		1
33	04217	Collar w/Gear	2m21T	1
34	04218	Gear	2m29T	1
35	04219	Gear	2m46T	1
36	04220	Gear	2m38T	1
37	04221	Collar		1
38	04222	Gear	2m26T	1
39	04223	Gear	2m34T	1
40	04224	Gear	2.25m53T	1
41	04225	Plug		1
59	TS-1504041	Socket Head Cap Screw	M8 x 20	1
73	GHB1340-4501	Gasket		1
74	GHB1340-4502	Gasket		1
80	GHB1340-4508	Oil Seal	20 x 40	1
84	TS-1501041	Hex Socket Cap Screw	M4 x 12	3
86	TS-1503031	Hex Socket Cap Screw	M6 x 12	3
98	TS-1523031	Set Screw	M6 x 8	4
105	GHB1340-105	Key	5 x 50	1
109	GHB1340-109	Key	6 x 120	1
111	GHB1340-111	Key	5 x 20	1
119	GHB1340-119N	C-Clip	35	1
124	GHB1340-124	Bearing	20 x 47 x 14	1
125	GHB1340-125	Bearing	17 x 40 x 12	1
126	GHB1340-126	Bearing	20 x 47 x 14	2
137	GHB1340-137	O-Ring	40 x 3.1	1
138	GHB1340-138	O-Ring	47 x 3.1	1
150	GHB1340A-150	Key	6 x 55	2
158	TS-1551061	Lock Washer	M8	1
	VB-A31	V-Belt (not shown)	A31	2
98A	GH-1440K02752	Screw		2

6.1 GHB-1340A/1440A Headstock Assembly III – Exploded View

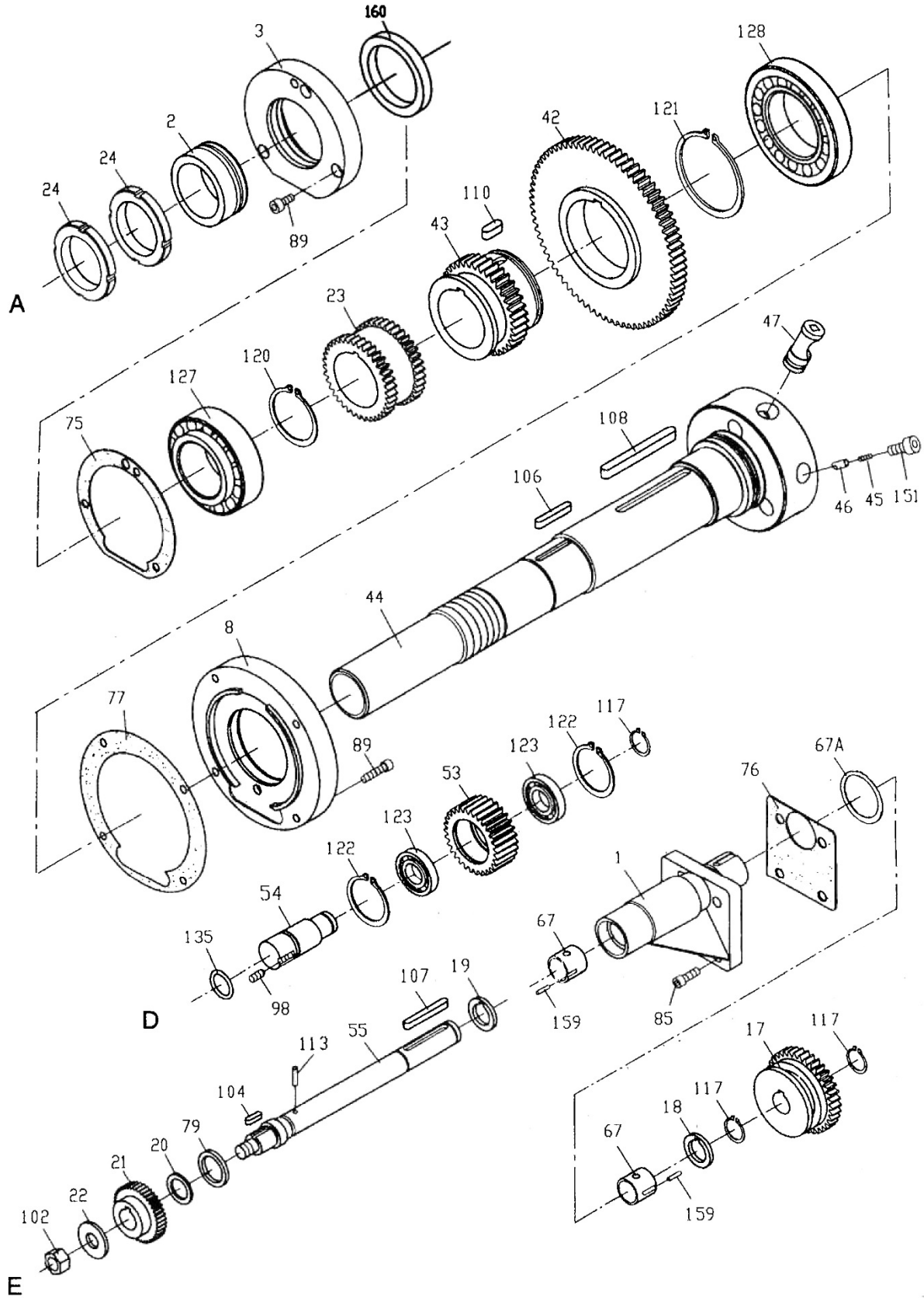

6.2 GHB-1340A/1440A Headstock Assembly III – Parts List

Index No	Part No	Description	Size	Qty
1	GHB1340A-02103	Collar	1-1/4" I.D. C'bore	1
	GHB1340A-02103N	Collar	1-3/8" I.D. C'bore	1
2	04102	Collar (serial #07061677A and lower)		1
	C0632A-02117A	Collar (serial #07061678A and higher)		1
3	GHB1340-4103N	Rear Cover (serial #07061677A and lower)		1
	C0632A-02115A	Rear Cover (serial #07061678A and higher)		1
8	04108Z	Front Cover		1
17	04201	Gear	2m37T	1
18	04202Z	Washer		1
19	04203Z	Washer		1
20	04204	Washer		1
21	04205A	Gear	1.25m32T	1
22	04206	Washer	12	1
23	04207A	Gear	2m37T	1
24	04208	Lock Nut		2
42	04226	Gear	2.25m74T	1
43	04227	Gear	2.25m37T	1
44	GHB1340A-02702	Spindle		1
45	04229	Spring	0.6 x 4 x 16	3
46	04230	Pin		3
47	04231	Cam		3
53	04237	Gear	2m30T	1
54	04238	Shaft		1
55	GHB1340A-02701	Shaft		1
67	04401	Collar		2
67A	GHB1340-67A	O-ring	32 x 3.1	1
75	GHB1340-4503	Gasket		1
76	GHB1340A-02501	Gasket		1
77	GHB1340-4505	Gasket		1
79	GHB1340-4507	Oil Seal	B-22x35x7	1
85	TS-1502041	Hex Socket Cap Screw	M5 x 16	4
89	TS-1503061	Hex Socket Cap Screw	M6 x 25	7
98	TS-1523031	Set Screw	M6 x 8	1
102	TS-1540081	Hex Nut	M12	1
104	GHB1340-104	Key	5 x 18	1
106	GHB1340-106	Key	6 x 40	1
107	GHB1340-107	Key	6 x 50	1
108	GHB1340-108	Key	8 x 85	1
110	GHB1340-110	Key	8 x 18	1
113	GHB1340-113	Pin	3 x 10	1
117	GHB1340-117N	C-Clip	20	2
120	GHB1340-120	C-Clip	50	1
121	GHB1340-121	C-Clip	72	1
122	GHB1340-122	C-Clip	42	2
123	GHB1340-123	Bearing	20 x 42 x 8	2
127	GHB1340-127	Bearing	50 x 90 x 20	1
128	GHB1340-128	Bearing	60 x 110 x 22	1
135	GHB1340-135	O-Ring	25 x 2.4	1
151	GHB1340A-151	Hex Socket Cap Screw	M8 x 18	3
159	GHB1340A-159	Pin	2 x 16	2
160	GB13871	Oil Seal (serial #07061678A and higher)	B-60x80x8	1

7.1 Bed Assembly I – Exploded View

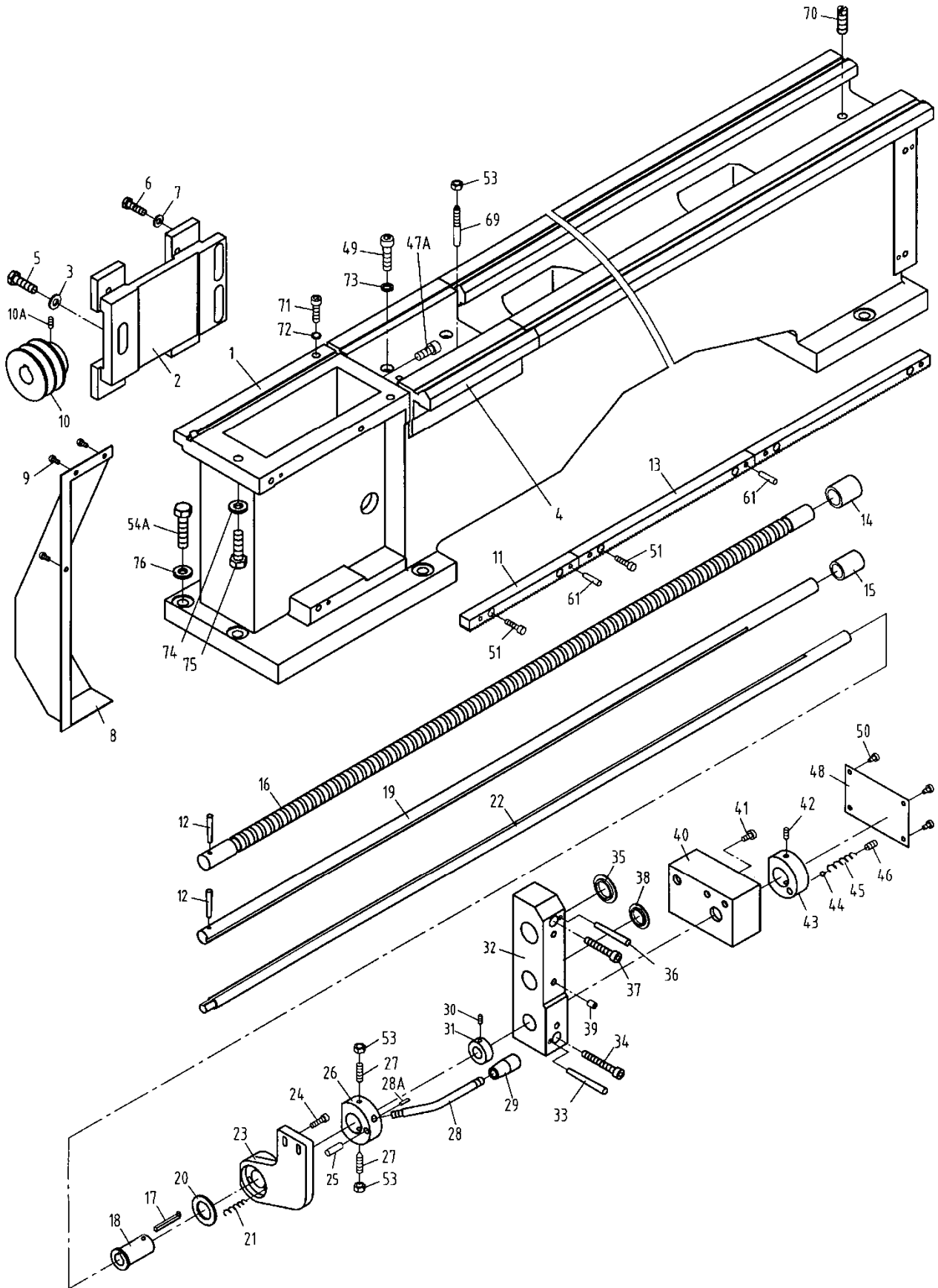

7.2 Bed Assembly I – Parts List

Index No	Part No	Description	Size	Qty
1	GHB1340A-01101	Bed		1
2	GHB1340A-1110	Motor Base		1
3	TS-1550071	Washer	M10	3
4	GHB1340-1102	Gap Bridge		1
5	TS-149105	Hex Cap Bolt	M10 x 35	3
6	TS-1490041	Hex Cap Bolt	M8 x 25	4
7	TS-1550061	Washer		4
8	GHB1340A-02703	End Cover (GHB-1340A only)		1
	GHB1440A-02703	End Cover (GHB-1440A only)		1
9	GHB1340A-9B	Screw	M5 x 8	3
10	GHB1340-01112	Pulley		1
10A	TS-1523041	Set Screw	M6 x 12	1
11	01203	Rack		1
12	GHB1340A-12B	Pin	5 x 35	2
13	01204-2	Rack		2
14	32A1105	Collar		1
15	32A1106	Collar		1
16	GHB1340A-1701	Lead Screw	GHB-1340A	1
	BDB1340A-1701	Lead Screw	BDB-1340A	1
17	321728	Key		1
18	321706	Collar		1
19	GHB1340A-1702	Feed Rod	GHB-1340A	1
	BDB1340A-1702	Feed Rod	BDB-1340A	1
20	01707	Brake Ring		1
21	GHB1340A-21B	Spring	1 x 7.5 x 25	3
22	GHB1340A-1703	Shaft	GHB-1340A	1
	BDB1340A-1703	Shaft	BDB-1340A	1
23	32A1103A	Bracket		1
24	TS-1503061	Hex Socket Cap Screw	M6 x 22	4
25	GHB1340A-25B	Pin	6 x 25	1
26	32A1710	Handle Hub		1
27	TS-1524061	Screw	M8 x 28	2
28	01710A	Handle		1
28A	GHB1340A-77	Pin	3 x 10	1
29	GHB1340A-29B	Knob	BM10 x 50	1
30	TS-1522031	Set Screw	M5 x 8	1
31	01708	Collar		1
32	32A1104A	Bracket		1
33	GHB1340A-33B	Pin	6 x 70	1
34	TS-1504131	Hex Socket Cap Screw	M8 x 65	1
35	32A1502	Plug		1
36	GHB1340A-36B	Pin	6 x 65	2
37	TS-1504121	Hex Socket Cap Screw	M8 x 60	2
38	32A1502	Plug		1
39	GHB1340A-39B	Oil Ball	8	3
40	32A1301	Switch Box		1
41	TS-1504041	Hex Socket Cap Screw	M8 x 20	4
42	TS-1523051	Screw	M6 x 16	1
43	32A1705	Bushing		1
44	SB-6MM	Steel Ball	6	1
45	GHB1340A-45B	Spring	1X5X22	1
46	TS-1524041	Screw	M8 x 16	1
47A	TS-1525021	Set Screw	M10 x 12	1
48	32A1504	Switch Box Cover		1
49	TS-1505051	Hex Socket Cap Screw	M10 x 35	4
50	TS-1502021	Socket Head Cap Screw	M5 x 10	4
51	TS-1503061	Hex Socket Cap Screw	M6 x 25	8
53	TS-1540061	Hex Nut	M8	4
54A	TS-1492061	Hex Cap Bolt	M12 x 60	6
61	GHB1340-61B	Pin	6 x 30	6

Index No	Part No	Description	Size	Qty
69	GHB1340-69B	Pin	8 x 60	2
70	GHB1340A-74B	Set Screw	M12 x 40	1
71	TS-1504071	Hex Socket Cap Screw	M8 x 35 (BDB)	2
	TS-1504081	Hex Socket Cap Screw	M8 x 40 (GHB)	2
72	TS-1551061	Lock Washer	M8	4
73	TS-1551071	Lock Washer	M10	4
74	TS-1550061	Washer	M8 (BDB)	2
	TS-1550061	Washer	M8 (GHB)	4
75	TS-1504091	Hex Socket Cap Screw	M8 x 45	2
76	TS-2360121	Washer	12	6

8.1 Bed Assembly II – Exploded View

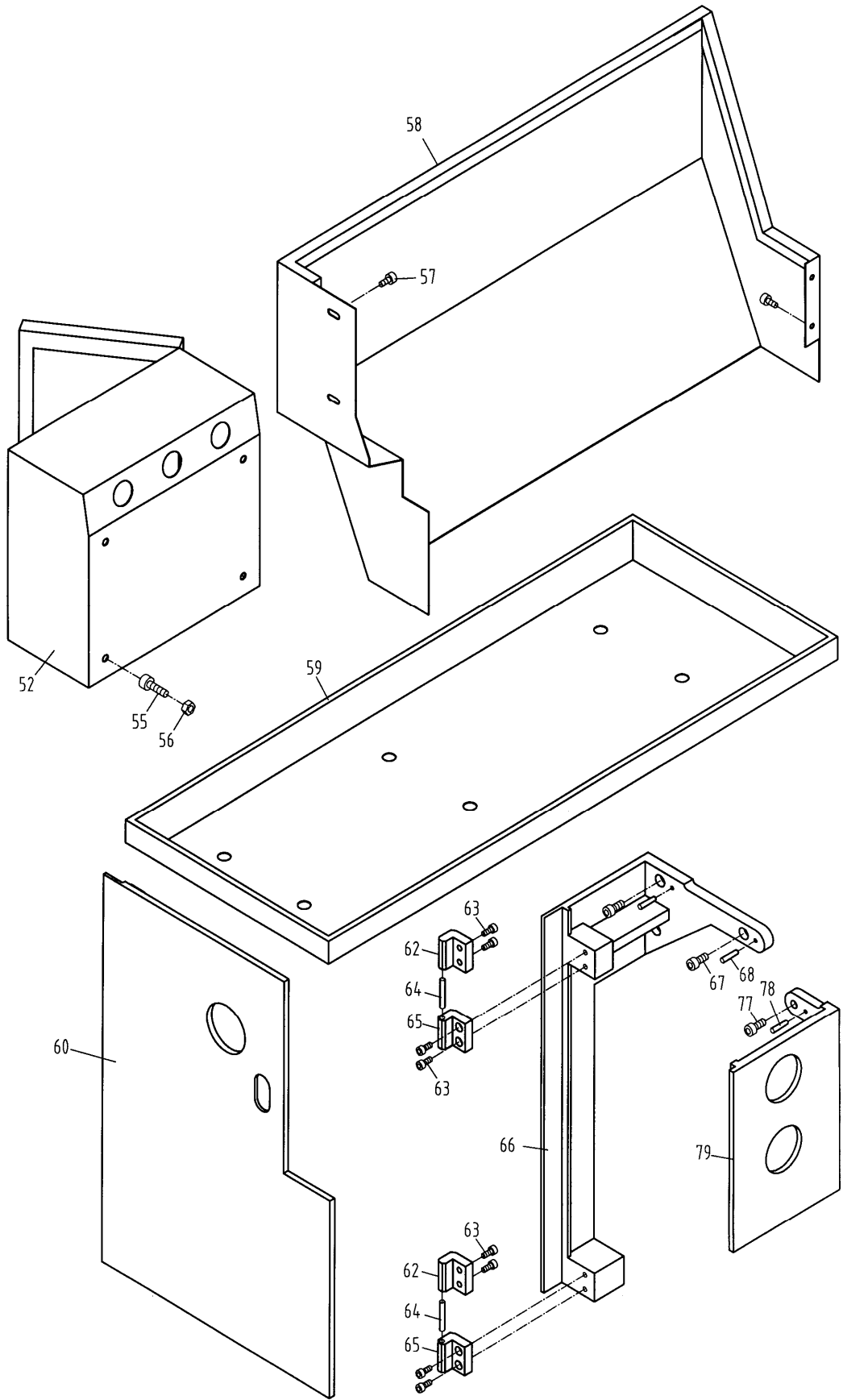

8.2 Bed Assembly II – Parts List

Index No	Part No	Description	Size	Qty
52	GHB1340A-18701	Electrical Box	GHB-1340A	1
52A	BDB1340A-18701	Electrical Box	BDB-1340A	1
55	GHB1340A-55B	Screw	M6 x 20	4
56	GHB1340A-56B	Nut	M6	4
57	GHB1340A-57B	Screw	M6 x 10	4
58	GHB1340A-12701	Splash Guard (serial #11072601A and lower)	GHB-1340A	1
	GHB1340A-12701A	Splash Guard (serial #11082602A and higher)	GHB-1340A	1
	GHB1440A-12701	Splash Guard	GHB-1440A	1
	BDB1340A-12701B	Splash Guard	BDB-1340A	1
59	GHB1340A-01701	Oil Plate (serial #12042866A and lower)	GHB-1340A	1
	GHB1340A-01701BJ	Oil Plate (serial #12092867A and higher)	GHB-1340A	1
	C0632-01727	Oil Plate	GHB-1440A	1
	BDB1340A-01701B	Oil Plate (serial #1204B1274A and lower)	BDB-1340A	1
	BDB1340A-01701BJ	Oil Plate (serial #1205B1275A and higher)	BDB-1340A	1
60	GHB1340A-02302	Back Cover	GHB/BDB-1340A	1
	C0636A-01501	Back Cover	GHB-1440A	1
62	ZX-8712	Upper Hinge		2
63	TS-1503041	Hex Socket Cap Screw	M6 x 14	8
64	GHB1340A-64B	Pin	10m6 x 40	2
65	ZX-8711	Lower Hinge		2
66	GHB1340A-02105	Rear Side Plate	GHB/BDB-1340A	1
	GHB1440A-02105	Rear Side Plate	GHB-1440A	1
67	TS-1504031	Hex Socket Cap Screw	M8 x 14	3
68	GHB1340A-68B	Pin	6 x 25	2
77	TS-1502041	Hex Socket Cap Screw	M5 x 14	2
78	GHB1340A-78B	Pin	5 x 25	2
79	GHB1340A-02104	Front Side Plate	GHB/BDB-1340A	1
	GHB1440A-02104	Front Side Plate	GHB-1440A	1

9.1 Gear Assembly I – Exploded View

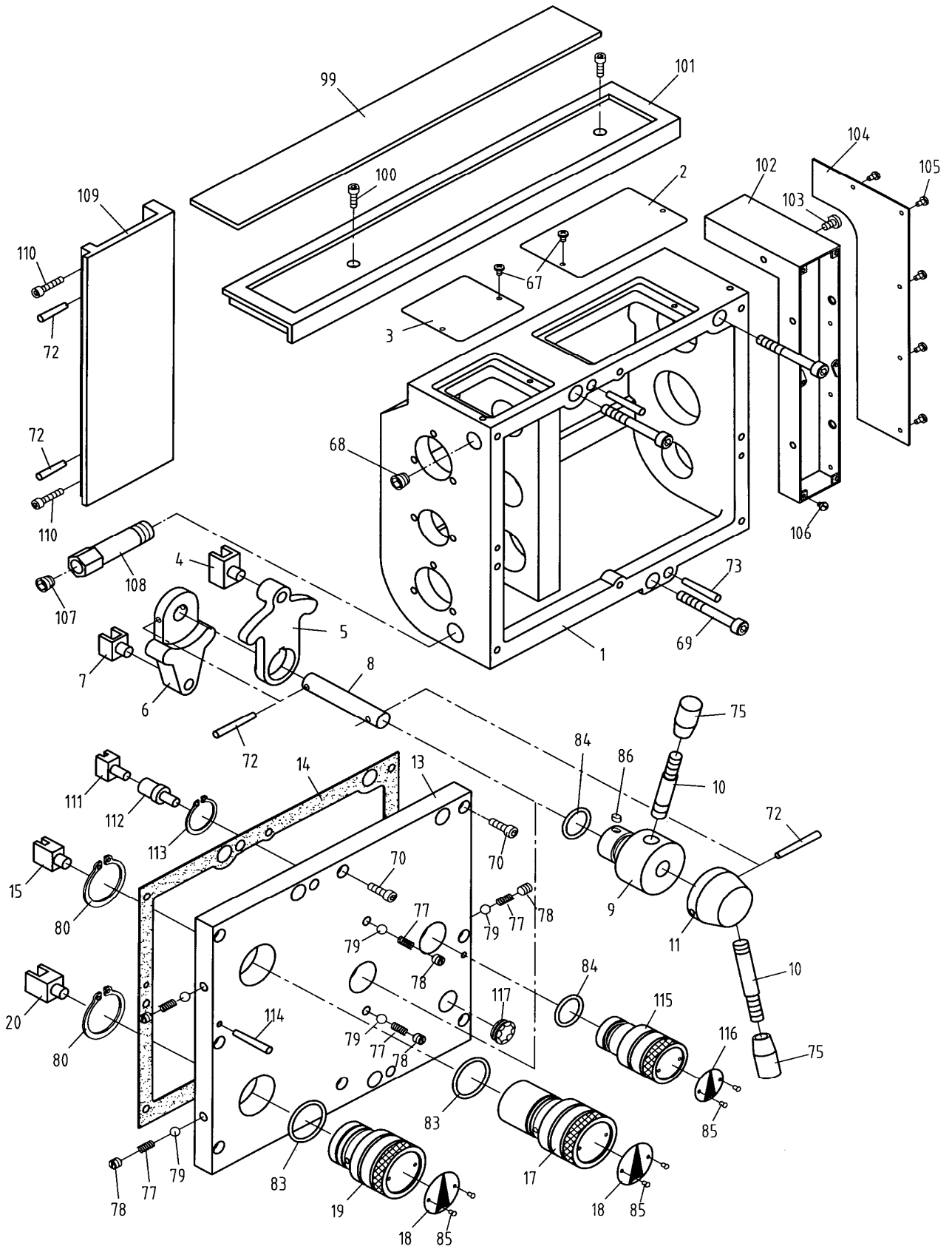

9.2 Gear Assembly I – Parts List

Index No	Part No	Description	Size	Qty
1	05101A	Casting		1
2	05715	Right cover		1
3	05720	Left cover		1
4	32A5308	Slipper		1
5	32A5111A	Lever		1
6	32A5108A	Lever		1
7	32A5307	Slipper		1
8	32A5702	Shaft		1
9	32A5109	Handle Base		1
10	32A5701	Lever		2
11	32A5110	Handle Base		1
13	GHB1340A-05106	Cover		1
14	05504	Gasket		1
15	32A5305	Slipper		1
17	32A5106	Lever		1
18	32A5302	Plate		2
19	32A5103	Handle		1
20	32A5306	Slipper		1
67	GHB1340A-G67	Screw	M4 x 6	6
68	GHB1340A-G68	Tapered Tap	ZG3/8"	2
69	GHB1340A-G69	Socket Head Cap Screw	M8 x 65	3
70	TS-1503061	Socket Head Cap Screw	M6 x 25	8
72	GHB1340A-G72	Pin	5 x 30	4
73	GHB1340A-G73	Pin	5 x 40	2
75	GHB1340A-G75	Knob	BM10 x 50	2
77	GHB1340A-G77	Spring	0.8 x 5 x 25	5
78	TS-1524021	Socket Set Screw	M8 x 10	5
79	SB-6.5MM	Steel Ball	6.5	5
80	GHB1340A-G80	C-clip	40	2
83	GHB1340A-G83	O-Ring	40 x 3.1	2
84	GHB1340A-G84	O-Ring	30 x 3.1	2
85	GHB1340A-G85	Screw	M3 x 6	6
86	GHB1340A-G86	Key	5 x 8	1
99	GHB1340A-05503	Rubber Mat (GHB-1340A only)		1
	GHB1440A-05503	Rubber Mat (GHB-1440A only)		1
	BDB1340A-05503	Rubber Mat (BDB-1340A only)		1
100	TS-1502041	Socket Set Screw	M5 x 16	2
101	GHB1340A-05105	Top Cover (GHB-1340A only)		1
	GHB1440A-05105	Top Cover (GHB-1440A only)		1
	BDB1340A-05105	Top Cover (BDB-1340A only)		1
102	05723	Cover		1
103	GHB1340A-G103	Screw	M4 x 8	3
104	05722	Plate		1
105	GHB1340A-G105	Screw	M3 x 5	5
106	GHB1340A-G106	Screw	M3 x 6	6
107	GHB1340A-G107	Tapered Tap	Z1/4"	1
108	05724	Oil Drain Pipe		1
109	05108	Extending Plate		1
110	TS-1502061	Socket Head Cap Screw	M5 x 25	2
111	05305	Slipper		1
112	05721	Slipper Shaft		1
113	GHB1340A-G113	C-clip	30	1
114	GHB1340A-G114	Pin	5 x 30	2
115	05107	Lever		1
116	05304	Sign Disc		1
117	GHB1340A-G117	Oil Sight Glass (GHB-1340A, serial #10052363A and lower)	12mm	1
	GHB1340A-G117	Oil Sight Glass (BDB-1340A, serial #1008B1083A and lower)	12mm	1
	GHB1340A-160M	Oil Sight Glass (GHB-1340A, serial #10102364A and higher)	M27x1.5	1
	GHB1340A-160M	Oil Sight Glass (BDB-1340A, serial #1010B1084A and higher)	M27x1.5	1
	GHB1340A-05306	Sign Plate (not shown)		1
	BDB1340A-05301	Sign Plate (not shown)		1

10.1 Gear Assembly II – Exploded View

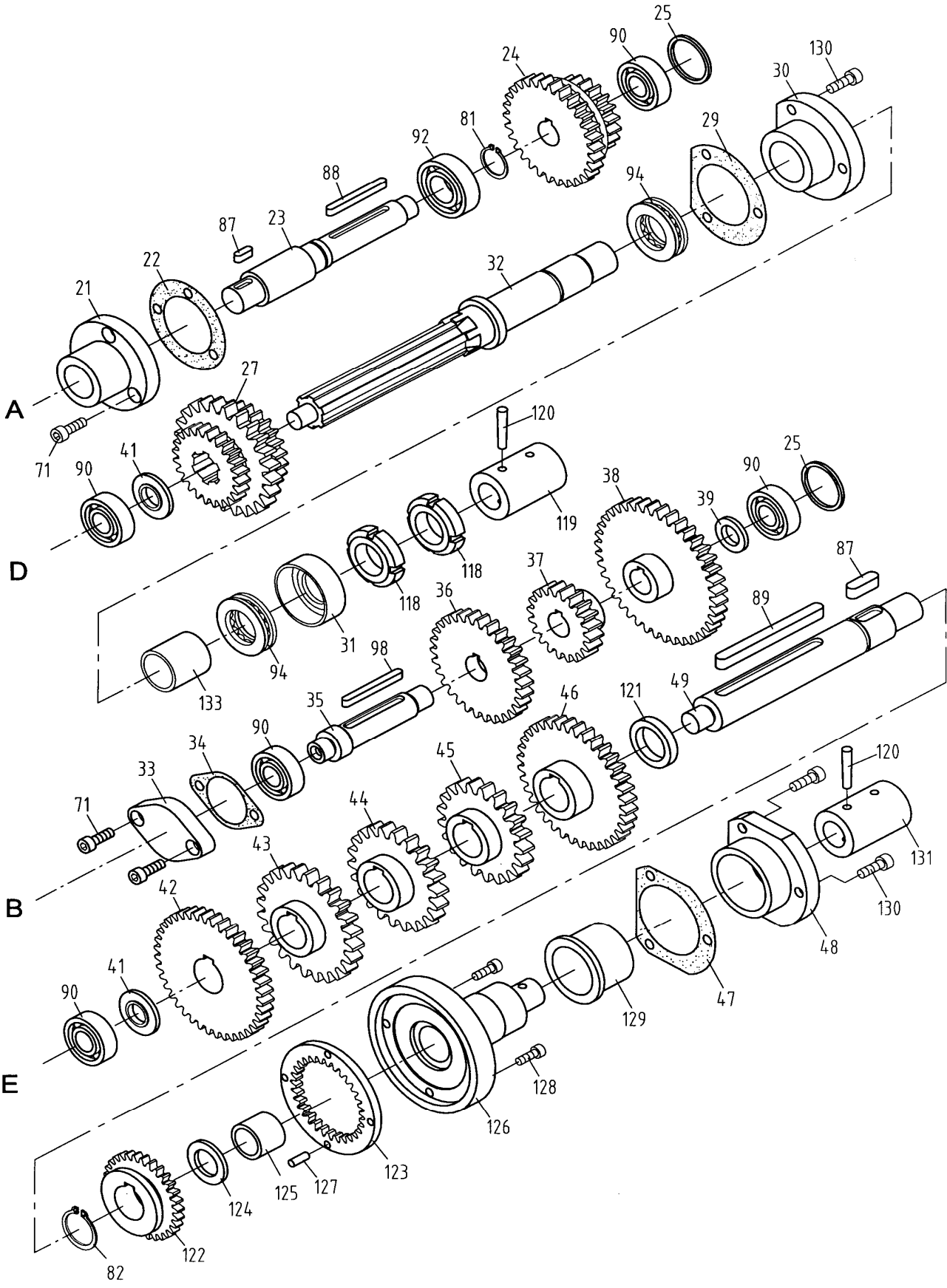

10.2 Gear Assembly II – Parts List

Index No	Part No	Description	Size	Qty
21	32A5113	Cover		1
22	32A5503	Gasket		1
23	32A5712	Shaft		1
24	32A5710A	Gear	2.5m30T, 20T	1
25	32A5719	Washer		2
27	05718	Gear	2.25m, 3.25m, 2.5m24T	1
29	05502	Gasket		1
30	05104	Bushing		1
31	05714	Washer		1
32	05716	Shaft		1
33	32A5114	End cover		1
34	32A5504	Gasket		1
35	32A5716	Shaft		1
36	32A5714A	Gear	2.5m30T	1
37	32A5715A	Gear	2.5m20T	1
38	32A5713A	Gear	2.5m40T	1
39	32A5708	Washer		2
41	05719	Washer		2
42	05702	Gear	2.25m40T	1
43	05703	Gear	3.25m24T	1
44	05704	Gear	3.25m22T	1
45	05705	Gear	3.25m21T	1
46	05706	Gear	2.5m36T	1
47	05501	Gasket		1
48	05103	Flange		1
49	05717	Shaft		1
71	TS-1504031	Socket Head Cap Screw	M6 x 16	5
81	GHB1340A-G81	C-clip	20	1
82	GHB1340A-G82	C-clip	25	1
87	GHB1340A-G87	Key	5 x 14	1
88	GHB1340A-G88	Key	5 x 50	1
89	GHB1340A-G89	Key	8 x 110	1
90	BB-6202	Bearing	6202	5
92	BB-6004	Bearing	6004	1
94	BB-51105	Thrust Bearing	51105	2
98	GHB1340A-G98	Key	5 x 55	1
118	GHB1340A-G118	Round Nut	M24 x 1.5	2
119	05713	Connecting Sleeve	GHB1340A	1
	BDB1340A-05713	Connecting Sleeve		1
120	GHB1340A-G120	Pin	5 x 35	4
121	05707	Washer		1
122	05708	Gear	2m30T	1
123	05709	Inner Gear	2m30T	1
124	05711	Washer		1
125	05302	Oil Light Bushing		1
126	05710	XIB Shaft		1
127	GHB1340A-G127	Pin	5n6 x 14	2
128	GHB1340A-G128	Screw	M5 x 10	2
129	05301	Sliding Bearing		1
130	TS-1503031	Socket Head Cap Screw	M6 x 12	6
131	GHB1340A-05712	Connecting Sleeve	GHB-1340A	1
	BDB1340A-05712	Connecting Sleeve	BDB-1340A	1
133	05303	Bearing Housing		1

11.1 Gear Assembly III – Exploded View

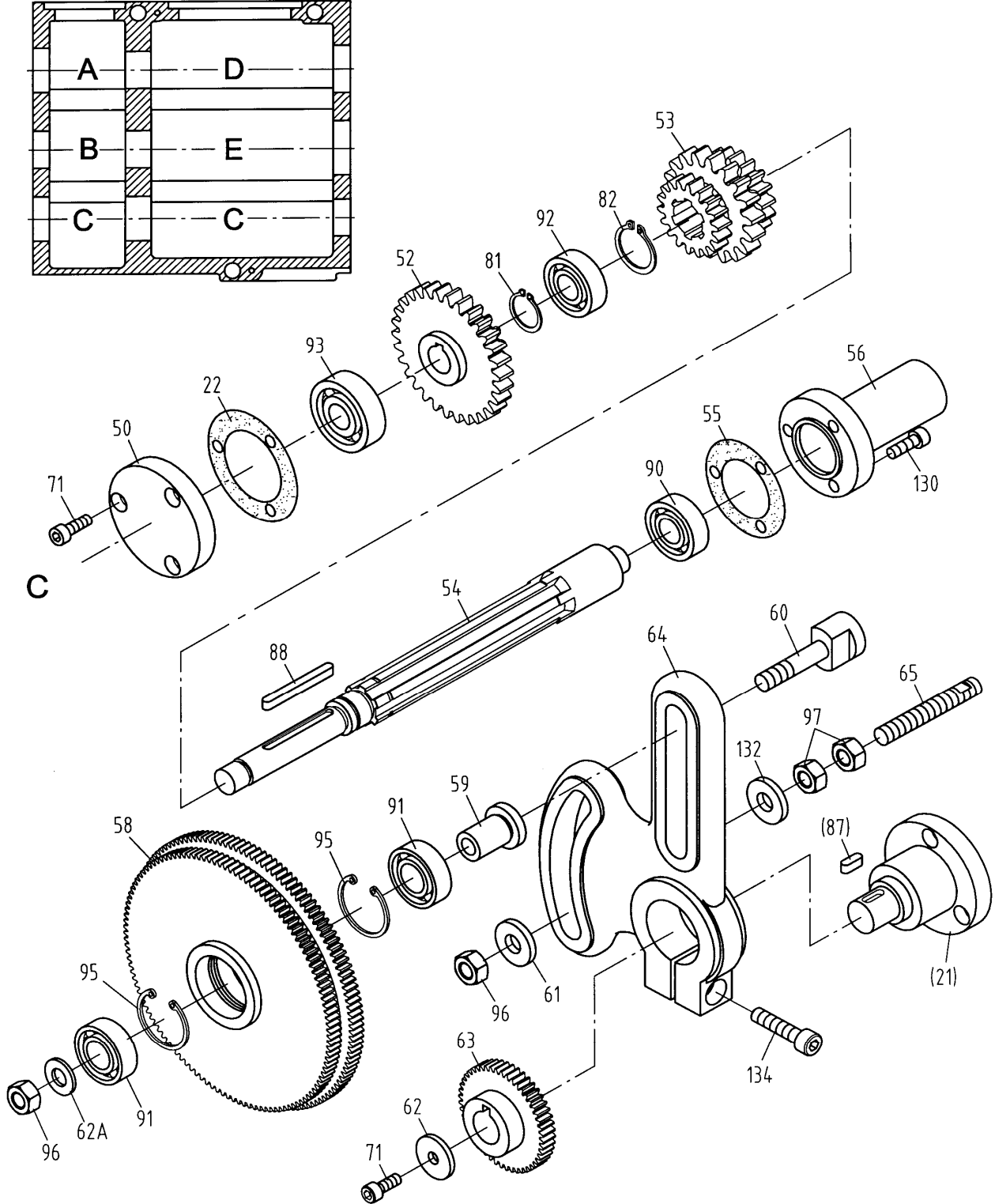

11.2 Gear Assembly III – Parts List

Index No	Part No	Description	Size	Qty
21	32A5113	Cover		1
22	32A5503	Gasket		1
50	32A5115	End Cover		1
52	32A5718A	Gear	2.5m30T, 15T	1
53	32A5721A	Gear	2.25m, 3.25m, 2.5m18T	1
54	05701	Key shaft		1
55	05505	Gasket		1
56	05102	Cover		1
58	40A5736	Gear	1.25m120T, 127T	1
59	40A5738	Collar		1
60	40A5739	Screw		1
61	321719	Washer		1
62	40A5740	Washer		2
62A	40A5740A	Washer		1
63	32A5726A	Gear	1.25m48T	5
64	32A5119	Gear Frame		1
65	321718	Screw rod		1
71	TS-1504031	Socket Head Cap Screw	M6 x 16	4
81	GHB1340A-G81	C-clip	20	1
82	GHB1340A-G82	C-clip	25	1
87	GHB1340A-G87	Key	5 x 14	1
88	GHB1340A-G88	Key	5 x 50	1
90	BB-6202	Bearing	6202	1
91	BB-6103	Bearing	6103	2
92	BB-6004	Bearing	6004	1
93	BB-6302	Thrust Bearing	6302	1
95	GHB1340A-G95	C-clip	35	2
96	TS-1540071	Hex Nut	M10	1
97	TS-1540081	Hex Nut	M12	3
130	TS-1503031	Socket Head Cap Screw	M6 x 12	3
132	TS-2360121	Washer		1
134	GHB1340A-G134	Hex Socket Cap Screw	M8 x 30	1

12.1 Apron Assembly I – Exploded View

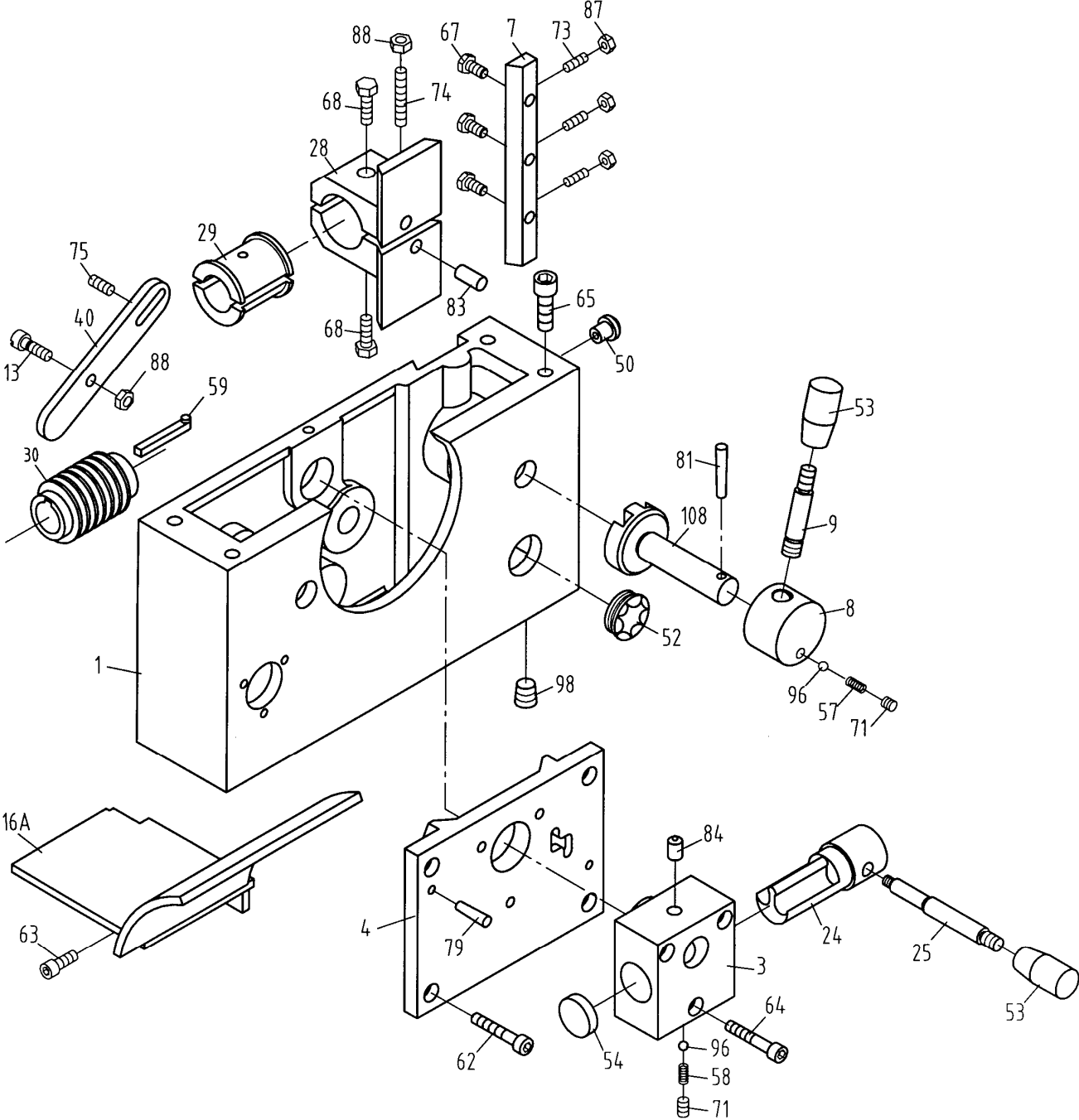

12.2 Apron Assembly I – Parts List

Index No	Part No	Description	Size	Qty
1	GHB1340A-06101A	.. Casting.....		1
3	06103 Housing.....		1
4	06104 Cover		1
7	06107 Gib		1
8	06208 Handle Hub.....		1
9	06209 Handle		1
13	06213 Gear Pin.....		1
16A	06415 Bracket.....		1
24	06222 Shift Lever.....		1
25	06223 Shift Handle		1
28	06126 Bracket.....		1
29	06427 Half Nut.....		1
30	06228 Worm (LH Thread).....	2m1T.....	1
	06228A Worm (RH Thread)	2m1T.....	1
40	06238 Bar		1
50	06548 Oil Filler Plug		1
52	06551 Oil Sight Glass (GHB-1340A serial #10052363A and lower)		1
	06551 Oil Sight Glass (BDB-1340A serial #1008B1083A and lower)		1
	GHB1340A-160M Oil Sight Glass (GHB-1340A serial #10102364A and higher).....	M27x1.5	1
	GHB1340A-160M Oil Sight Glass (BDB-1340A serial #1010B1084A and higher).....	M27x1.5	1
53	06553 Knob	M8 x 40	2
54	Z06554 Plug "A"		1
57	06257 Spring		1
58	06258 Spring		1
59	06260 Key.....		1
62	TS-1503031 Hex Socket Cap Screw.....	M6 x 12	4
63	TS-1503041 Hex Socket Cap Screw.....	M6 x 16	1
64	TS-1503061 Hex Socket Cap Screw.....	M6 x 25	2
65	TS-1504061 Hex Socket Cap Screw.....	M8 x 30	4
67	GHB1340-A67 Screw.....	M5 x 16	3
68	TS-1523041 Set Screw	M6 x 12	2
71	TS-1523011 Set Screw	M6 x 6	3
73	TS-1522051 Set Screw	M5 x 16	3
74	GHB1340-A74 Set Screw	M6 x 35	1
75	TS-1523031 Set Screw	M6 x 10	1
79	GHB1340-A79 Pin.....	5 x 20	2
81	GHB1340-A81 Pin.....	5 x 32	1
83	GHB1340-A83 Pin.....	8n6 x 12	2
84	GHB1340-A84 Oiler	8	2
87	TS-1540031 Hex Nut.....	M5	3
88	TS-1540041 Hex Nut.....	M6	2
96	SB-5MM Steel Ball.....	5	2
98	GHB1340A-A98 Plug.....	Z1/4".....	1
108	06261 Half Nut Controlling Shaft		1

13.1 Apron Assembly II – Exploded View

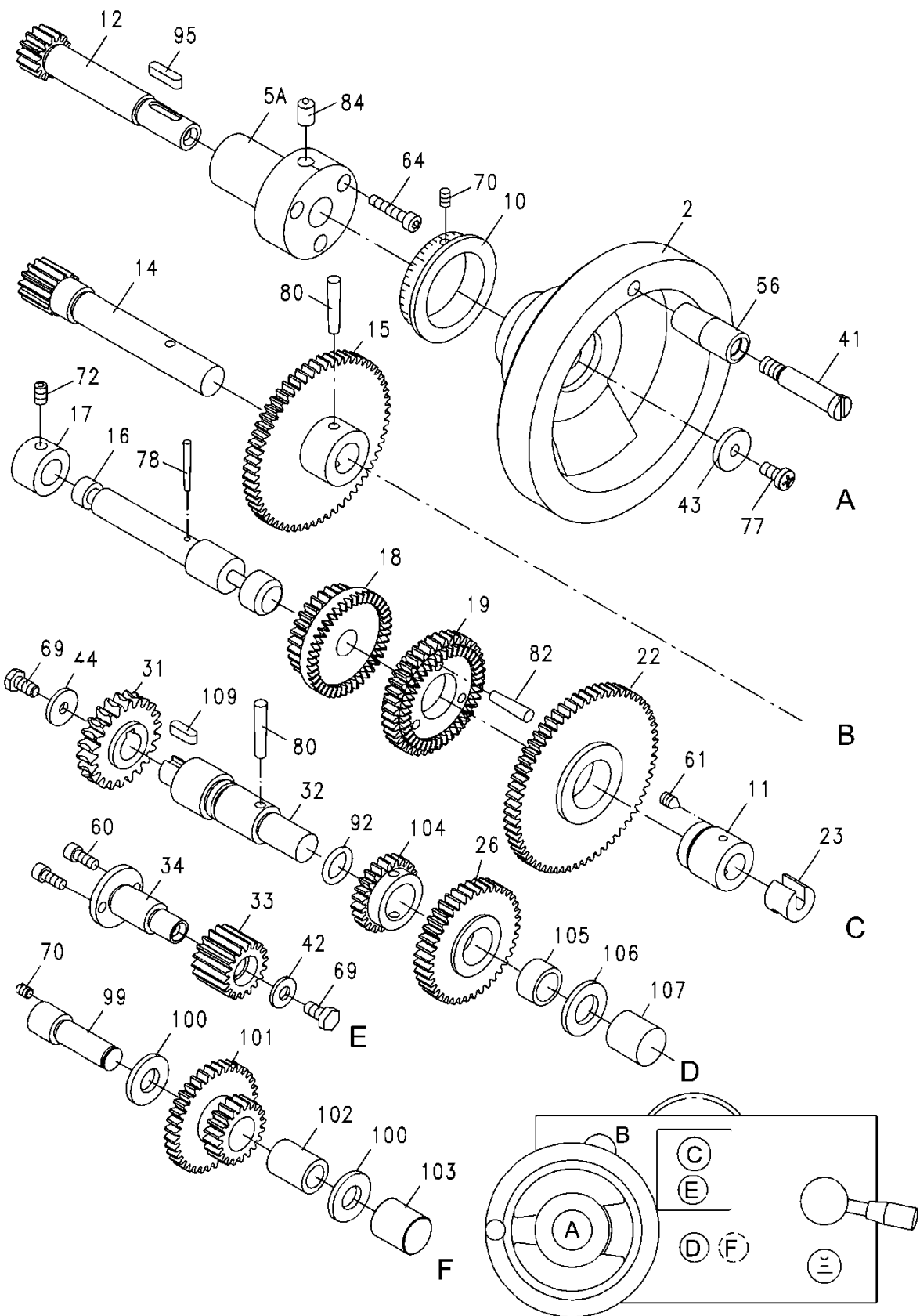

13.2 Apron Assembly II – Parts List

Index No	Part No	Description	Size	Qty
2	06102	Handwheel		2
5A	06105A	Hub		1
10	06510	Index Ring		1
11	Z06111	Cover		1
12	06212	Shaft	1.5m14T	1
14	06214	Gear Shaft	1.5m13T	1
15	06215	Gear	1.5m60T	1
16	06216	Shaft		1
17	06417	Collar		1
18	06218	Gear	1.5m30T	1
19	06219	Gear	1.5m40T	1
22	06220	Gear	1.5m46T	1
23	06421	Shift Fork		1
26	GHB1340A-06704	Gear	1.5m40T	1
31	06429	Gear	2m22T	1
32	GHB1340A-06714	Shaft		1
33	06231	Gear	1.5m18T	1
34	06232	Shaft		1
41	06239	Screw		1
42	TS-1550041	Washer		1
43	Z06241	Washer		1
44	06242	Washer		1
56	06556	Handle		1
60	TS-1502031	Hex Socket Cap Screw	M5 x 12	2
61	TS-1523011	Set Screw	M6 x 6	1
64	TS-1503061	Hex Socket Cap Screw	M6 x 25	3
69	TS-1503021	Screw	M6 x 10	2
70	TS-1522011	Set Screw	M5 x 6	2
72	TS-1523031	Set Screw	M6 x 10	1
77	GHB1340-A77	Screw	M6 x 12	1
78	GHB1340-A78	Pin	3 x 25	1
80	GHB1340-A80	Pin	5 x 30	2
82	GHB1340-A82	Pin	5 x 25	3
84	GHB1340-A84	Oiler	8	1
92	GHB1340-A92	O-Ring	20 x 2.4	2
95	GHB1340-A95	Key	A5 x 18	1
99	GHB1340A-06732	Shaft		1
100	GHB1340A-06114	Washer		2
101	GHB1340A-06734	Gear	1.5m20T, 36T	1
102	GHB1340A-06115	Collar		1
103	GHB1340A-A103	Shaft Plug		1
104	GHB1340A-06731	Gear	1.5m24T	1
105	GHB1340A-06113	Collar		1
106	GHB1340A-06111	Washer		1
107	GHB1340A-06112	Shaft Plug		1
109	GHB1340A-A109	Key	5 x 12	1

14.1 Apron Assembly III – Exploded View

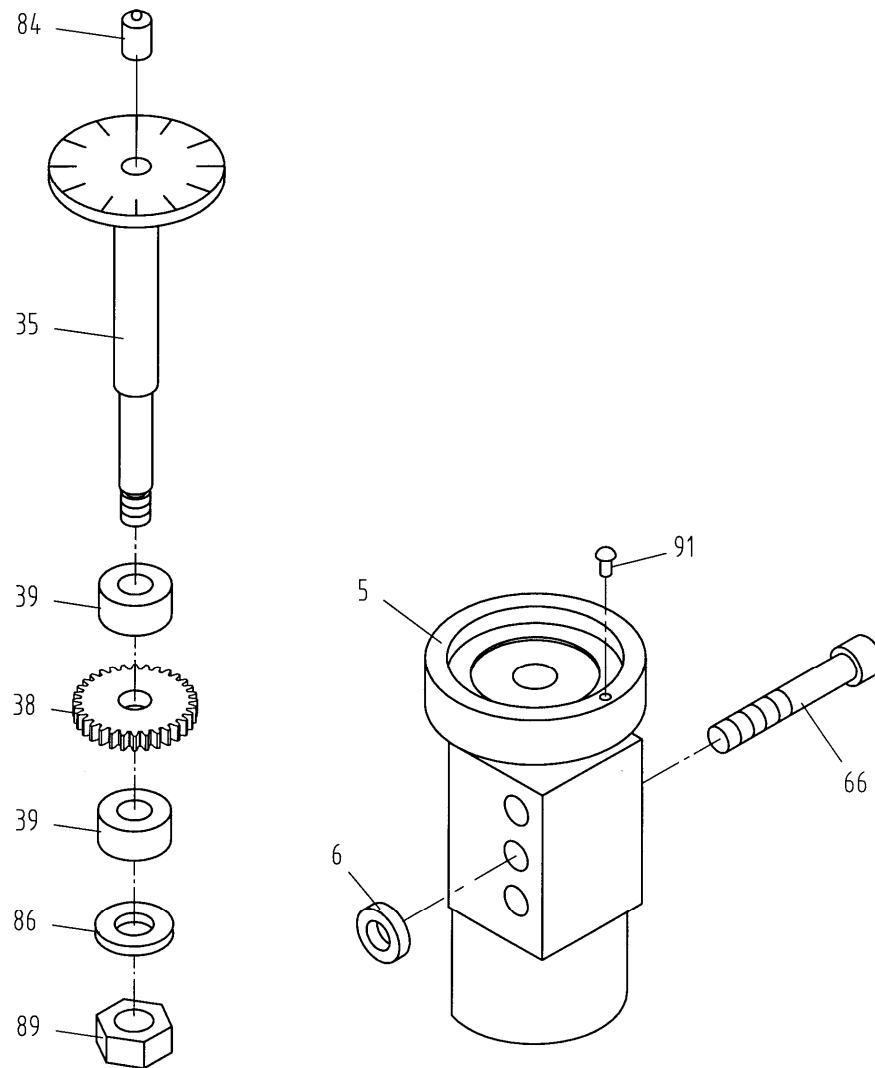

14.2 Apron Assembly III – Parts List

Index No	Part No	Description	Size	Qty
5	Z06105	Threading Dial Body		1
6	06206	Washer		1
35	06233	Threading Dial Shaft		1
38	06236	Gear	1m32T	1
39	06237	Spacer		2
66	TS-1504101	Hex Socket Cap Screw	M8 x 50	1
84	GHB1340-A84	Oiler	8	1
86	GHB1340-A86	Lock Washer	M8	1
89	TS-1540061	Hex Nut	M8	1
91	GHB1340-A91	Rivet	3 x 8	1

15.1 Micro Carriage Stop Assembly – Exploded View

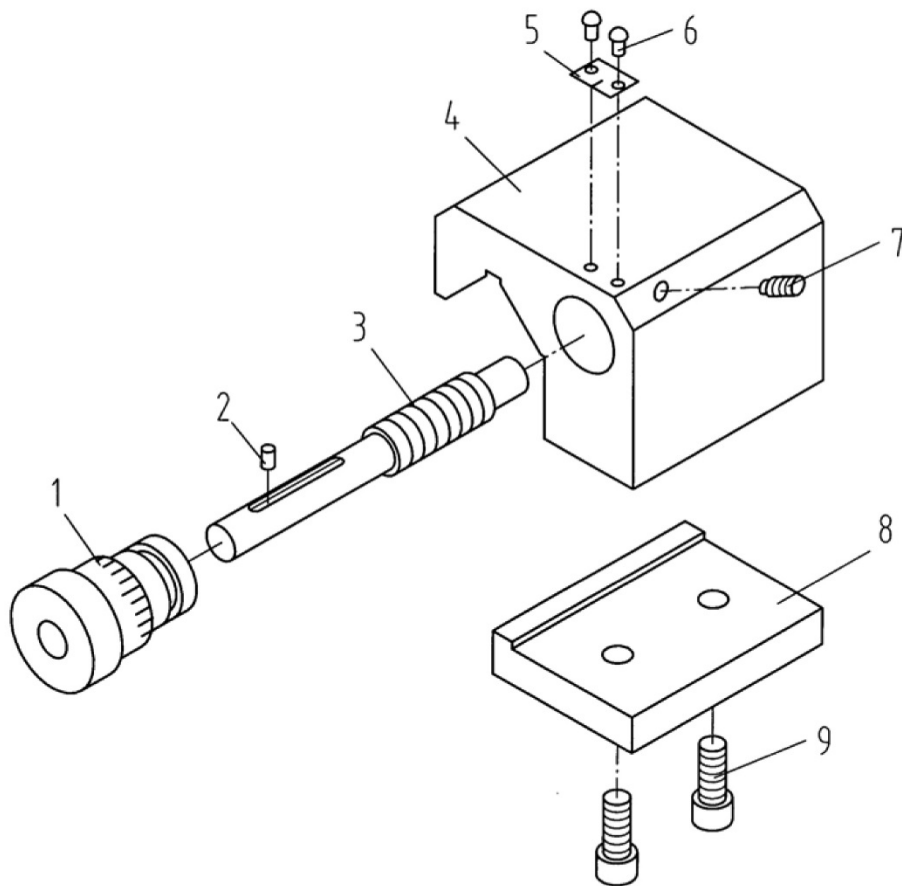

15.2 Micro Carriage Stop Assembly – Parts List

Index No	Part No	Description	Size	Qty
1	GHB1340A-01707	Dial		1
2	GHB1340A-MS02	Pin	B3 x 6	1
3	GHB1340A-01716	Axle		1
4	GHB1340A-01107	Stop		1
5	ZX-03302	Indicator Plate		1
6	ZX-MS06	Pin	3 x 8	2
7	TS-1523031	Socket Set Screw	M6 x 10	1
8	GH1340A-01108	Clamping Plate		1
9	TS-1503051	Hex Socket Cap Screw	M6 x 20	2

16.1 Top Slide, Tool Post, Saddle, and Cross Slide I – Exploded View

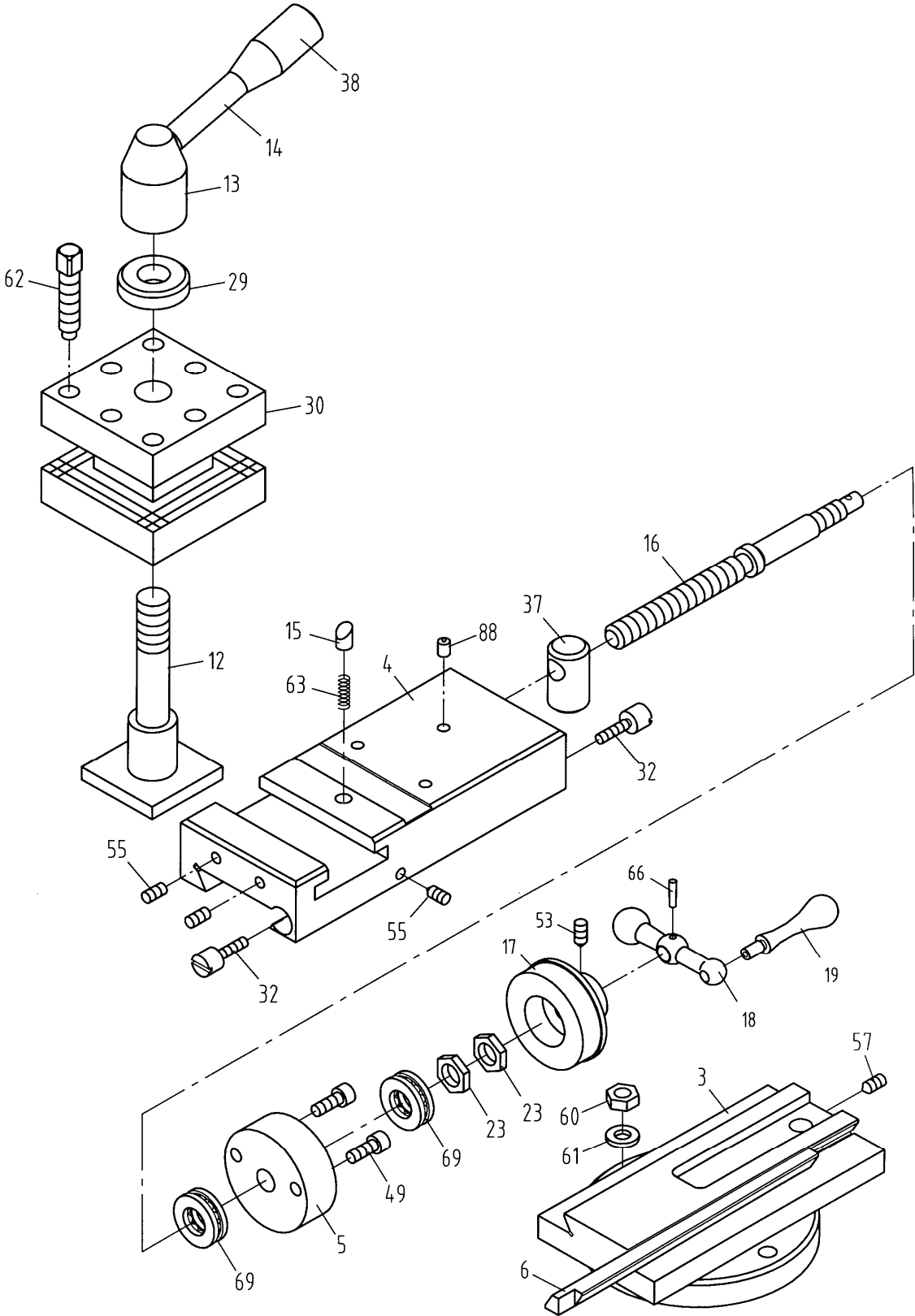

16.2 Top Slide, Tool Post, Saddle, and Cross Slide I – Parts List

Index No	Part No	Description	Size	Qty
3	07103	Swivel Slide		1
4	07104	Top Slide		1
5	07111	Collar		1
6	07117	Gib		1
12	07205	Screw		1
13	07206	Handle Base		1
14	07207	Handle Shaft		1
15	07209	Stop		1
16	07210	Screw		1
17	07212	Index Ring		1
18	07213	Ball Handle		1
19	07214	Handle		1
23	07221	Nut		2
29	07233	Washer		1
30	07234	Post Base		1
32	07237	Gib Adjusting Screw		2
37	07430	Nut		1
38	07508	Knob		1
49	TS-1503051	Hex Socket Cap Screw	M6 x 20	2
53	TS-1523011	Set Screw	M6 x 6	1
55	TS-1523031	Set Screw	M6 x 10	3
57	TS-1524011	Set Screw	M8 x 8	1
60	TS-1540061	Hex Nut	M8	2
61	TS-1550061	Washer	M8	1
62	GHB1340-62T	Screw	M10 x 40	8
63	GHB1340-63T	Spring	0.6 x 4x 18	1
66	GHB1340-66T	Pin	3 x 16	1
69	GHB1340-69T	Ball Bearing		2
	GHB1340-TSA	Top Slide Assembly w/o Tool Post		1
70	07545	Screw	M8 x 20	1
88	GHB1340-88	Oil Ball	6	1

17.1 Top Slide, Tool Post, Saddle, and Cross Slide II – Exploded View

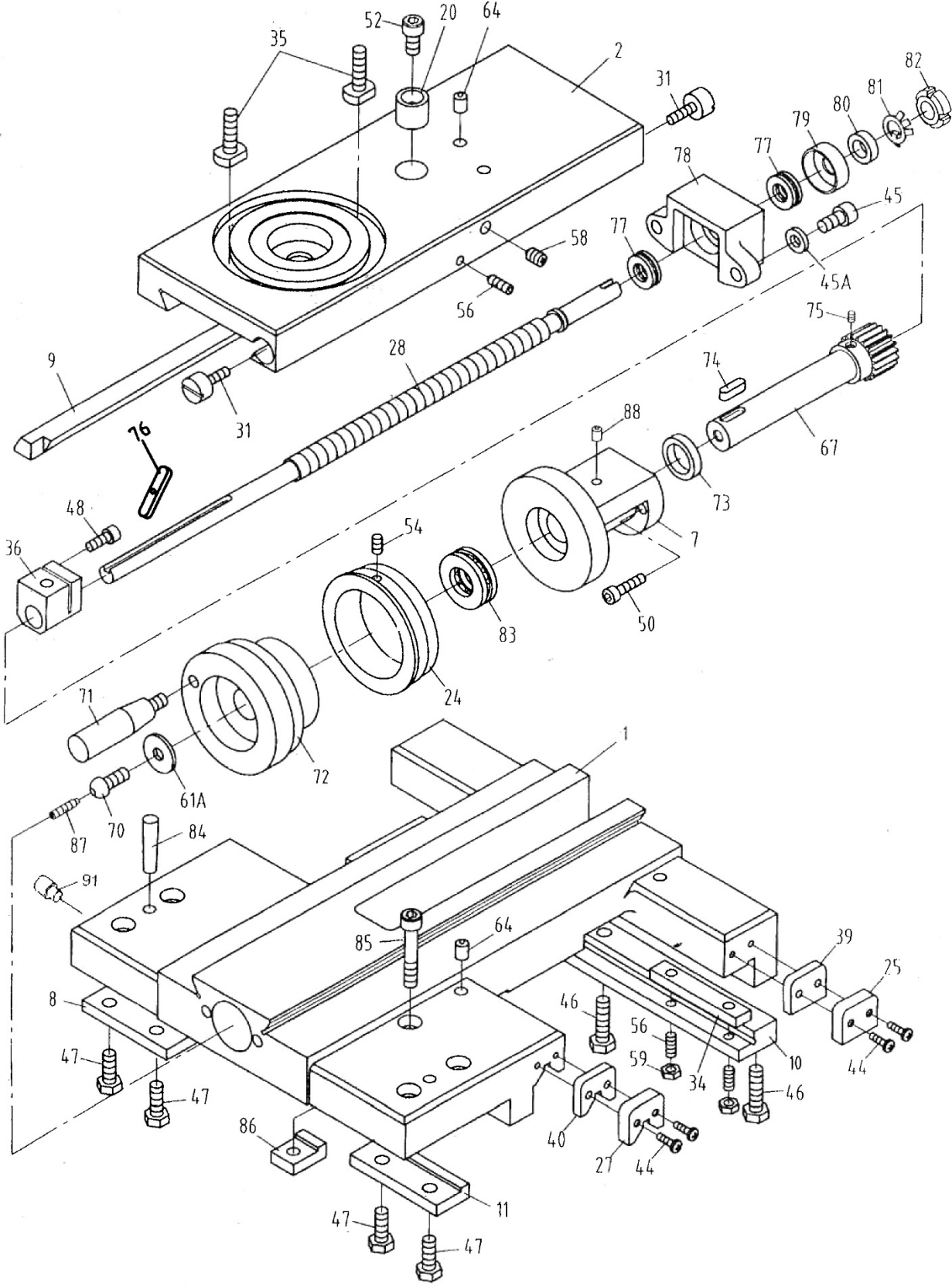

17.2 Top Slide, Tool Post, Saddle, and Cross Slide II – Parts List

Index No	Part No	Description	Size	Qty
1	07101	Saddle (GHB-1340A serial #07061685A and lower)		1
		(BDB-1340A serial #0706B0764A and lower)		1
	GHB-1340A-04101A	Saddle (GHB-1340A serial #07071686A and higher)		1
		(BDB-1340A serial #0707B0765A and higher)		1
2	07102	Cross Slide		1
7	07120N	Bearing Housing		1
8	07123	Strip		1
9	07131	Gib		1
10	07132	Strip		1
11	07141	Front Strip (GHB-1340A serial #07061685A and lower)		1
		(BDB-1340A serial #0706B0764A and lower)		1
	C0632-04111A	Front Strip (GHB-1340A serial #07071686A and higher)		1
		(BDB-1340A serial #0707B0765A and higher)		1
20	07216	Collar		1
24	07222N	Index Ring		1
25	07224	Plate		2
27	07227	Plate		2
28	07229N	Screw		1
31	07236	Gib Adjusting Screw		2
34	07239	Gib Strip		2
35	07240	T-Bolt		2
36	07415N	Block		1
39	07526	Wiper		2
40	07528	Wiper		2
44	GHB1340-44T	Screw	M4 x 12	8
45	TS-1504051	Hex Socket Cap Screw	M8 x 25	2
45A	TS-1551061	Lock Washer	M8	2
46	GHB1340-46T	Screw	M8 x 20	3
47	GHB1340-47T	Screw	M8 x 20	4
48	TS-1503041	Hex Socket Cap Screw	M6 x 16	1
50	TS-1503061	Hex Socket Cap Screw	M6 x 25	2
52	TS-1504031	Hex Socket Cap Screw	M8 x 16	1
54	TS-1523021	Set Screw	M6 x 8	1
56	TS-1523071	Set Screw	M6 x 25	5
58	TS-1524021	Set Screw	M8 x 10	1
59	TS-1540041	Hex Nut	M6	4
61	TS-1550061	Washer	M8	1
61A	GHB1340-65T	Washer		1
64	GHB1340-64T	Oil Ball	8	5
67	07530	Gear Shaft		1
70	TS-1504041	Screw	M8 x 20	1
71	07531	Handle		1
72	07532	Compound Handle		1
73	07533	Spacer		1
74	07534	Key		1
75	07535	Set Screw	M3 x 8	1
76	07536	Key	5 x 5 x 30	1
77	BB-8101	Thrust Bearing	8101	2
78	07538	Bearing Housing		1
79	07539	Bearing Dust Cover		1
80	07540	Washer		1
81	07541	Star Washer		1
82	07542	Locking Nut		1
83	BB-8104	Thrust Bearing	8104	1
84	GHB1340-84	Taper Pin	8 x 40	2
85	GHB1340-85	Hex Socket Cap Screw	M8 x 50	1
86	GHB1340-86	Locking Washer		1
87	GHB1340-87	Screw	M5 x 20	1
88	GHB1340-88	Oil Ball	6	1
91	GHB1340A-04789E	Stop Pin (GHB-1340A for serial #07071686A and higher)		1

18.1 Tailstock Assembly I – Exploded View

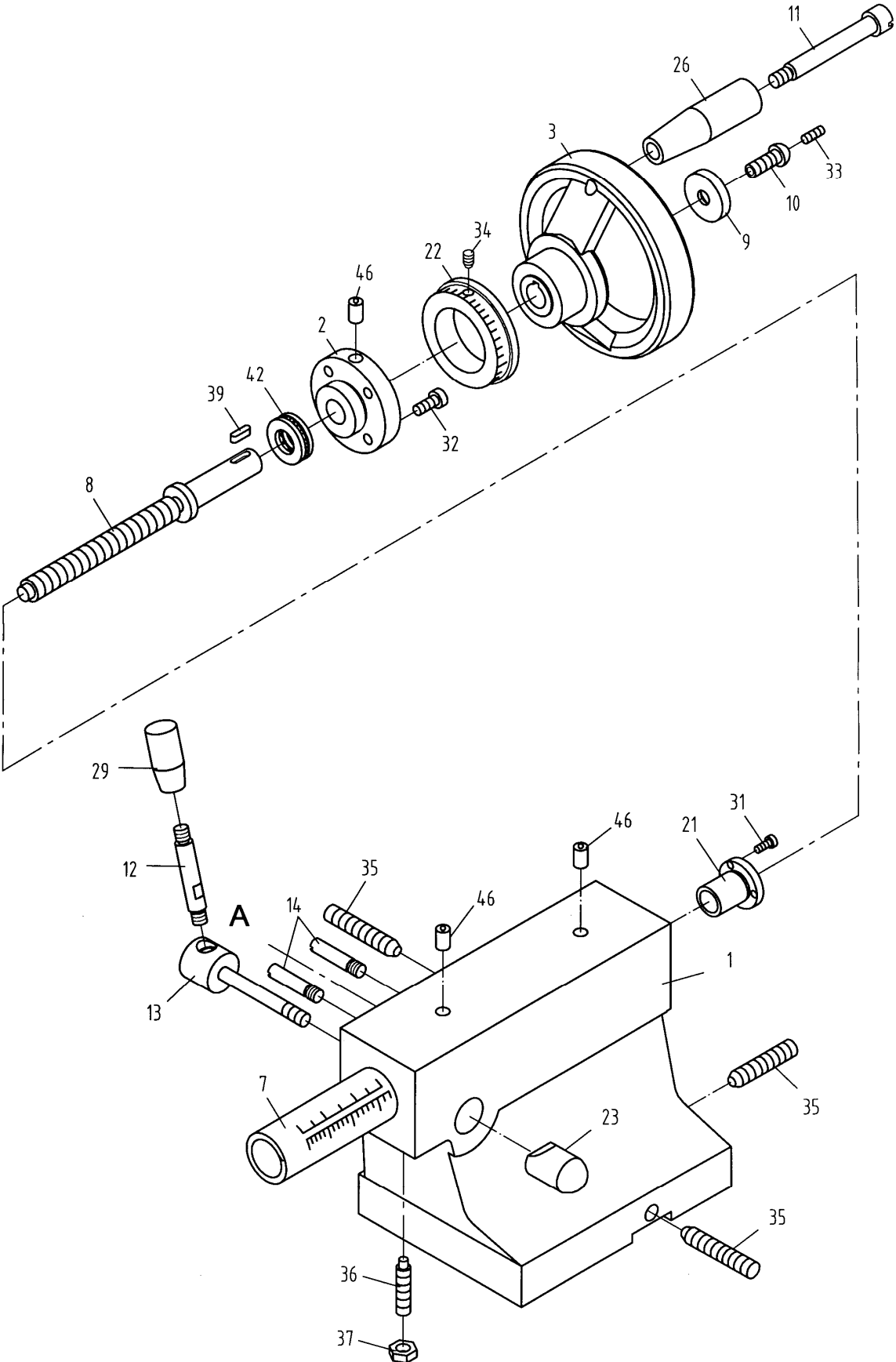

18.2 Tailstock Assembly I – Parts List

Index No	Part No	Description	Size	Qty
1	Z08101	Casting.....		1
2	Z08102	Flange Cover		1
3	08103	Hand Wheel		1
7	08202	Quill.....		1
8	Z08203	Screw.....		1
9	GHB1340-09TS	Washer		1
10	Z08205	Screw.....	M8 x 20	1
11	08206	Screw.....		1
12	Z08207	Lever.....		1
13	08208	Shaft		1
14	08209	Screw.....		2
21	08401	Nut		1
22	08402	Index Ring.....		1
23	08403	Pivot Block.....		1
26	08501	Handle		1
29	GHB1340-29TS	Handle	M8 x 40	1
31	TS-1501031	Hex Socket Cap Screw.....	M4 x 10	3
32	TS-1503041	Hex Socket Cap Screw.....	M6 x 16	4
33	TS-1522061	Set Screw	M5 x 20	1
34	TS-1523031	Set Screw	M6 x 8	1
35	GHB1340-35TS	Set Screw	M10 x 45	3
36	GHB1340-36TS	Screw.....	M8 x 35	1
37	TS-1540061	Hex Nut.....	M8	1
39	GHB1340-39TS	Key.....	4 x 15	1
42	BB-51102	Bearing	8102	1
46	GHB1340-43TS	Oil Ball	8	3
	Z08201	Live Center (not shown).....	MT3	1
	8404	Arrow Plate (not shown)		1
	8405	Scale Plate (not shown).....		1

19.1 Tailstock Assembly II – Exploded View

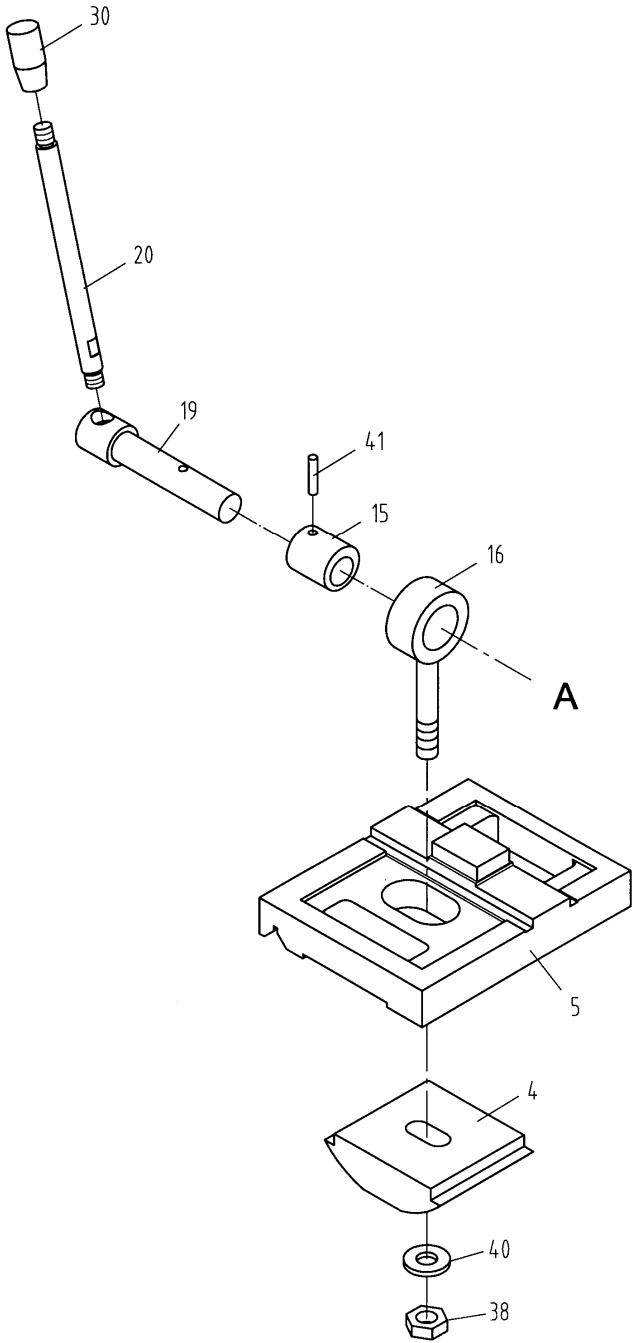

19.2 Tailstock Assembly II – Parts List

Index No	Part No	Description	Size	Qty
4	08104	Clamp Plate		1
5	08105	Base		1
15	08211	Collar		1
16	08212	Screw		1
19	08213	Shaft		1
20	08214	Lever		1
30	GHB1340-30TS	Knob	M10 x 50	1
38	TS-1540081	Hex Nut	M12	1
40	TS-2360121	Washer	M12	1
41	GHB1340-41TS	Pin	5 x 25	1

20.1 Follow Rest – Exploded View

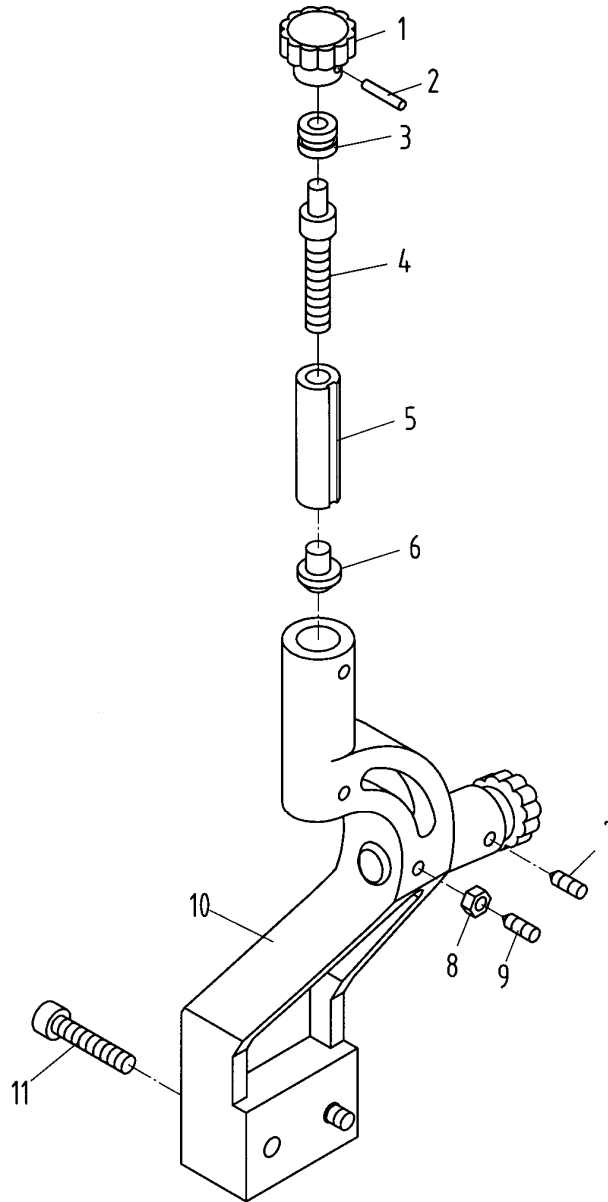

20.2 Follow Rest – Parts List

Index No	Part No	Description	Size	Qty
1	GHB1340-1FR	Knob		2
2	GHB1340-2FR	Pin	3 x 18	2
3	10208	Bushing		2
4	10204	Screw		2
5	10201	Sleeve		2
6	10401	Brass Finger		2
7	TS-1523011	Set Screw	M6 x 8	2
8	TS-1540041	Nut	M6	2
9	TS-1523051	Set Screw	M6 x 16	2
10	10104	Base Casting		1
11	TS-1504071	Hex Socket Cap Screw	M8 x 35	2
	GHB1340-FR	Follow Rest Complete		1

21.1 Steady Rest – Exploded View

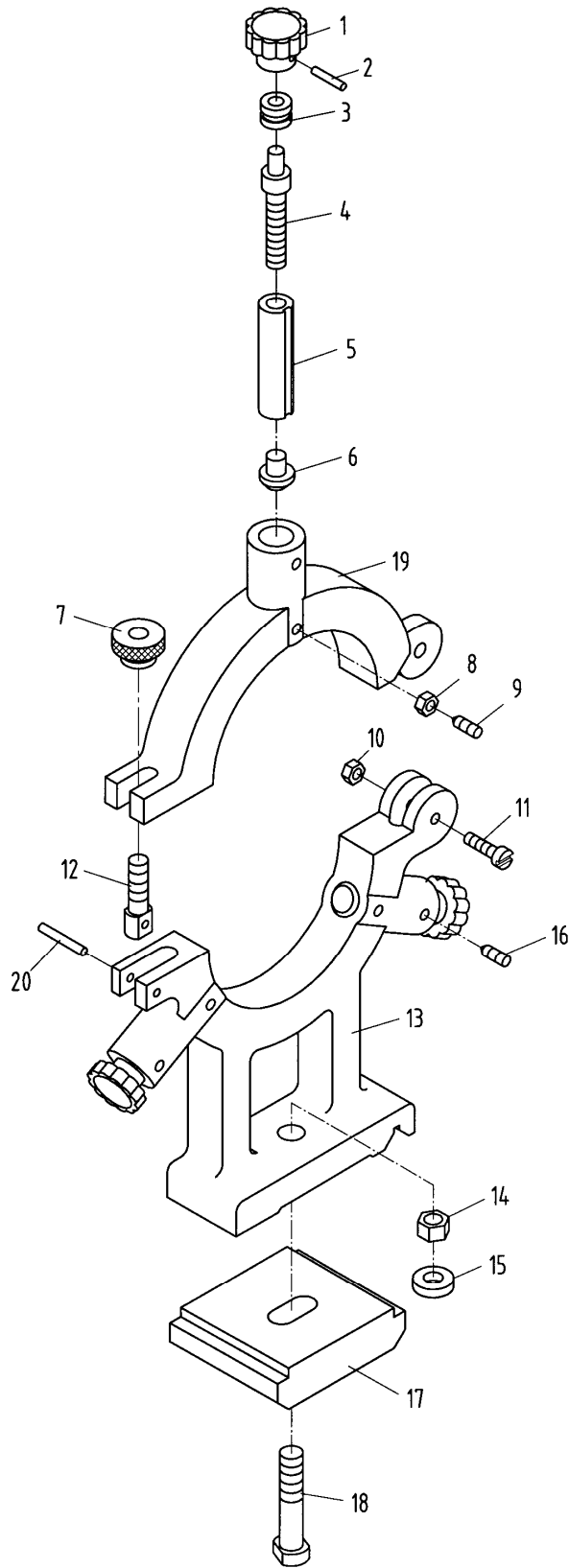

21.2 Steady Rest – Parts List

Index No	Part No	Description	Size	Qty
1	GHB1340-1FR	Knob		3
2	GHB1340-2FR	Pin	3 x 18	3
3	10203	Bushing		3
4	10204	Screw		3
5	10201	Sleeve		3
6	10401	Brass Finger		3
7	10205	Lock Knob		1
8	TS-1540041	Nut	M6	3
9	TS-1523051	Set Screw	M6 x 16	3
10	TS-1540041	Nut	M6	1
11	GHB1340-11SR	Bolt	M6 x 30	1
12	10206	Pivot Bolt		1
13	10102	Base Casting		1
14	TS-1540081	Nut	M12	1
15	TS-1550081	Flat Washer	M12	1
16	TS-1523021	Set Screw	M6 x 8	3
17	10103	Clamp Rod		1
18	TH1340-18SR	Clamp Screw		1
19	10101	Top Casting		1
20	GHB1340-20SR	Pin	5 x 25	1
	GHB1340-SR	Steady Rest Complete		1

22.1 GHB-1340A/1440A Chuck Guard Assembly – Exploded View

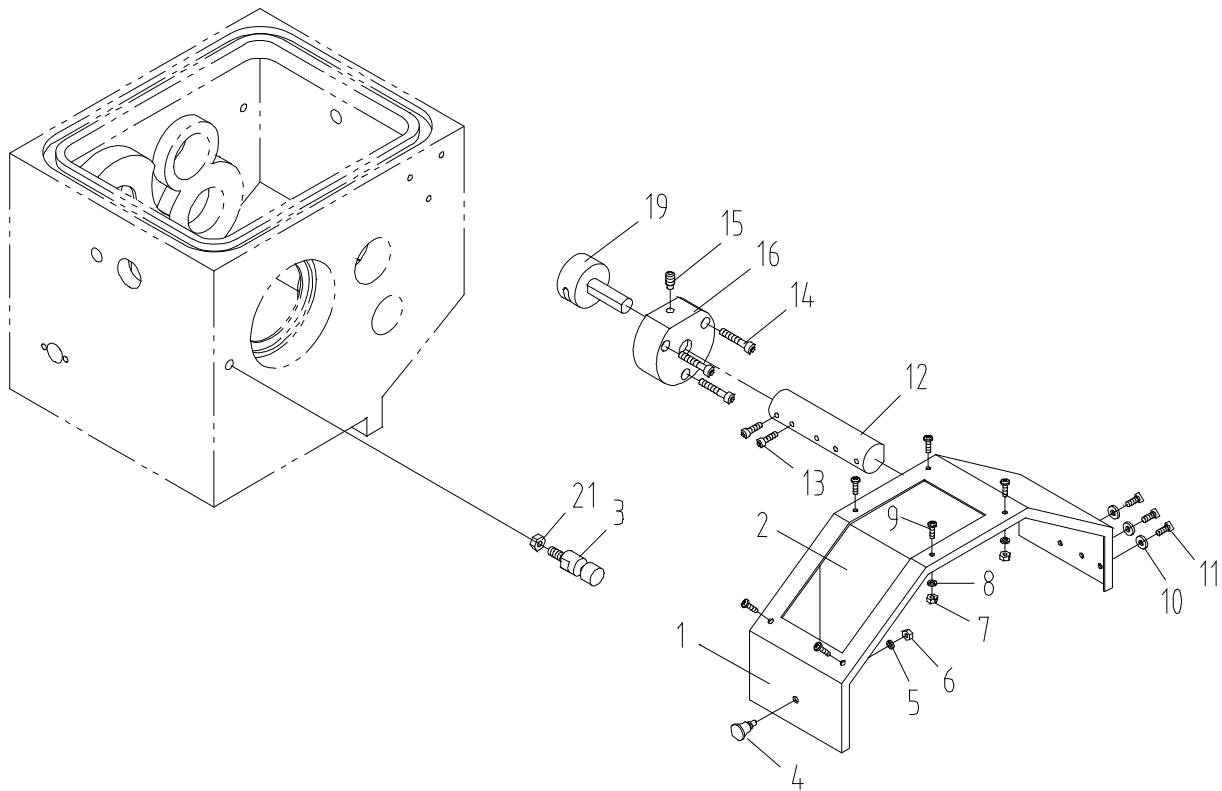

22.2 GHB-1340A/1440A Chuck Guard Assembly – Parts List

Index No	Part No	Description	Size	Qty
	GHB-CGA	Chuck Guard Assembly (index #1 thru 21)		1
1	GHB1340A-19701E	Protection Guard		1
2	GHB1340A-19501E	Protection Guard Visual Glass		1
3	ZX-19704E	Fixing Rod		1
4	SG-04	Handle	HY32-1	1
5	TS-2361051	Spring Lock Washer	5 mm	1
6	TS-1540031	Hex Nut	M5	1
7	ZX-S07E	Hex Thin Nut	M4	6
8	TS-1550031	Plain Washer	5 mm	6
9	TS-1532042	Cross Recessed Pan Head Screws	M4x12	6
10	TS-1550031	Plain Washer	5 mm	3
11	TS-1534032	Cross Recessed Pan Head Screws	M6x10	3
12	GHB1340A-19703E	Rest Bar		1
13	TS-1524021	Hex Socket Set Screw	M8x10	2
14	TS-1503071	Hex Socket Cap Screw	M6x30	3
15	TS-1524041	Hex Socket Set Screw	M8x16	1
16	GHB1340A19704	Switch Box		1
19	GHB1340A19702E	Shaft		1
21	ZXS21E	Nut	M8	1

23.0 Additional Parts (Not Shown)

Index No	Part No	Description	Size	Qty
	GHB1340-FP	Face Plate	12" D1-4	1
	GHB1340-TBC	Tool Box Complete		1
	321449	Chuck	6" 3 Jaw	1
	321430	Chuck	8" 4 Jaw	1
	GHB1340A-CG1	Change Gear	1.25m44T	1
	GHB1340A-CG2	Change Gear	1.25m48T	1
	GHB1340A-CG3	Change Gear	1.25m33T	1
	GHB1340A-CG4	Change Gear	1.25m46T	1
	GHB1340A-CG5	Change Gear	1.25m52T	1

24.0 Additional Electrical Components (Not Shown)

Index No	Part No	Description	Size	Qty
	BDB1340-QS1	Main Power Switch (BDB-1340A Only)		1
	BDB1340-QS1-A	Faceplate for Power Switch (BDB-1340A Only)		1
	BDB1340-QS1-B	Knob for Power Switch (BDB-1340A Only)		1
	321320	Motor (2HP, 1Ph, 60HZ 230V only for GHB-1340A/1440A)		1
	GHB1340-MP	Motor Pulley		1
	321321	Motor (2HP, 1Ph, 60HZ 230V only for BDB-1340A)		1
	BDB1340-MP	Motor Pulley		1
	GHB1340-C	Capacitor (same with BDB-1340A)		1
	GHB1340-CC	Capacitor Cover (same with BDB-1340A)		1
	GHB1340-CSF	Centrifugal Switch Fixture (same with BDB-1340A)		1
	GHB1340-CSR	Centrifugal Switch Rotor		1
	BDB1340-CSR	Centrifugal Switch Rotor		1
	GHB1340A-EBC	Electrical Box Complete		1
	BDB1340A-EBC	Electrical Box Complete		1
	GHB1340A-18701	Electrical Box (bare)		1
	BDB1340A-18701	Electrical Box (bare)		1
	GHB1340-JB	Motor Junction Box		1
	BDB1340-JB	Motor Junction Box		1
	GHB1340A-RSB	Rotary Switch Box		1
	GHB1340A-SP	Electric Switch Plate (GHB-1340A/1440A Only)		1

25.1 Electrical Schematic – GHB-1340A/1440A

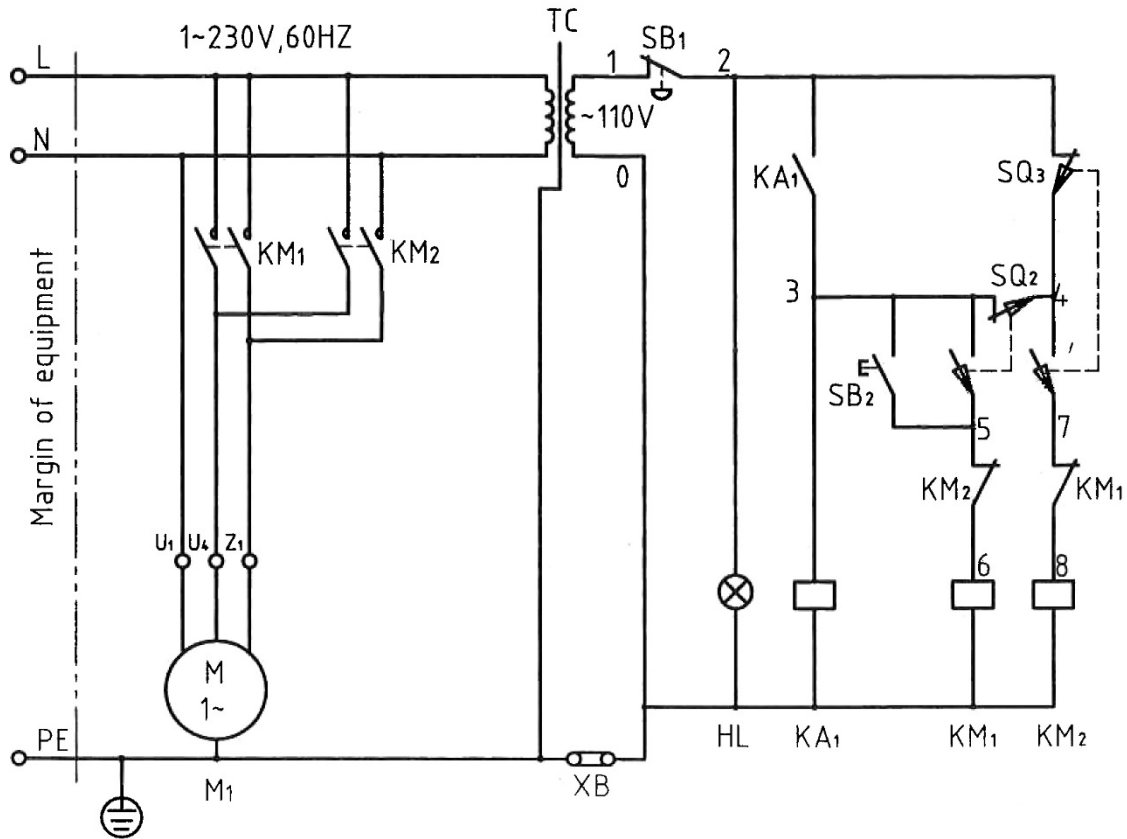

25.2 Electrical Schematic Parts List – GHB-1340A/1440A

Index No	Part No	Description	Size	Qty
1	GHB1340-SB1	Emergency Stop	LAY3-01ZS/1	1
2	GHB1340-SB2	Jog Button	LAY3-11	1
3	GHB1340-HL	Power Indicator Light	AD1-30/20	1
4	GHB1340-KA1	Magnetic Starter	CA2-DN140	1
5	GHB1340-KM1	Magnetic Starter	LC1-D259	1
6	GHB1340-KM2	Magnetic Starter	LC1-D259	1
7	GHB1340-TC	Control Transformer	JBK3-63	1
8	GHB1340A-SQ2	Stroke Switch	LXW5-11D1	1
9	GHB1340A-SQ3	Stroke Switch	LXW5-11D1	1
10	GHB1340-XT1	Wiring Board	JHY1-32	1
11	GHB1340-XT2	Wiring Board	JHY1-16	1
12	GHB1340-XB	Copper Plate (for grounding)		1

26.1 Electrical Schematic – BDB-1340A

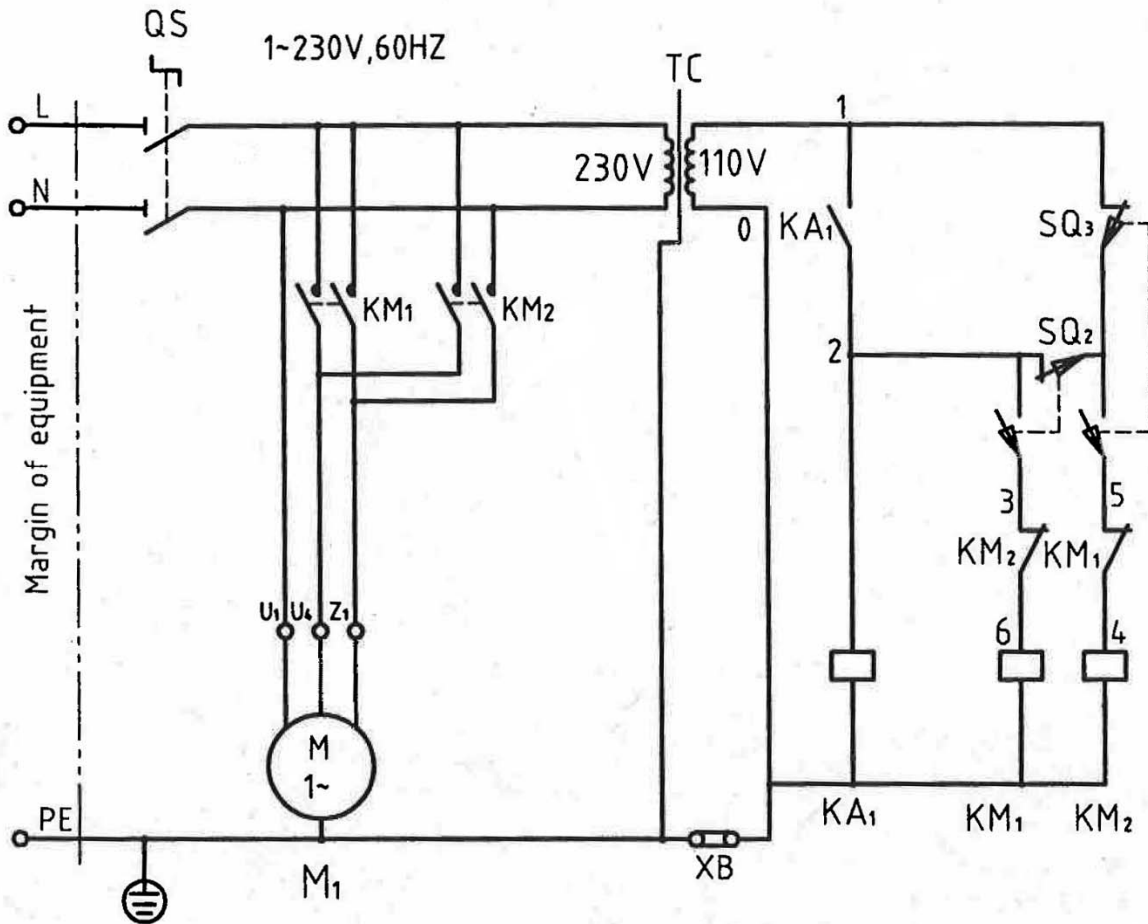

26.2 Electrical Schematic Parts List – BDB-1340A

Index No	Part No	Description	Size	Qty.
1	GHB1340-KA1	Relay	CA2-DN140	1
2	GHB1340-KM1	A.C. Contactor	LC1-D259	1
3	GHB1340-KM2	A.C. Contactor	LC1-D259	1
4	GHB1340-TC	Control Transformer	JBK3-63	1
5	GHB1340A-SQ2	Stroke Switch	LXW5-11D1	1
6	GHB1340A-SQ3	Stroke Switch	LXW5-11D1	1
7	GHB1340-XT1	Wiring Board	JHY1-32	1
8	GHB1340-XT2	Wiring Board	JHY1-16	1
9	GHB1340-XB	Copper Plate (for grounding)		1

27.0 GHB-1340A/1440A Wiring Photo

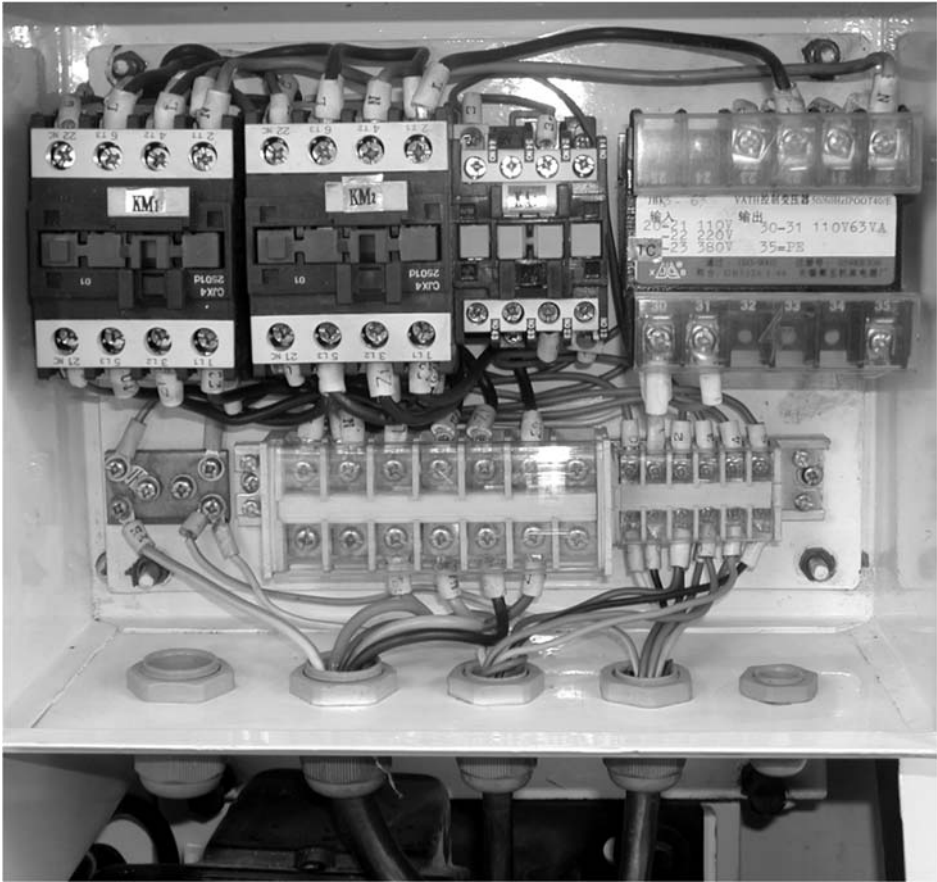

28.0 BDB-1340A Wiring Photo

