



# Operating Instructions and Parts Manual

## 5C Collet Closer for BDB-1340A Lathe

Model CC-BDB1340A



**JET**  
427 New Sanford Road  
LaVergne, Tennessee, 37086  
Ph.: 800-274-6848  
[www.jettools.com](http://www.jettools.com)

**Part No. M-321515A**  
Revision B 03/2014  
Copyright © 2014 JET

# Warranty and Service

JET warrants every product it sells against manufacturers' defects. If one of our tools needs service or repair, please contact Technical Service by calling 1-800-274-6846, 8AM to 5PM CST, Monday through Friday.

## Warranty Period

The general warranty lasts for the time period specified in the literature included with your product or on the official JET branded website.

- JET products carry a limited warranty which varies in duration based upon the product. (See chart below)
- Accessories carry a limited warranty of one year from the date of receipt.
- Consumable items are defined as expendable parts or accessories expected to become inoperable within a reasonable amount of use and are covered by a 90 day limited warranty against manufacturer's defects.

## Who is Covered

This warranty covers only the initial purchaser of the product from the date of delivery.

## What is Covered

This warranty covers any defects in workmanship or materials subject to the limitations stated below. This warranty does not cover failures due directly or indirectly to misuse, abuse, negligence or accidents, normal wear-and-tear, improper repair, alterations or lack of maintenance.

## Warranty Limitations

Woodworking products with a Five Year Warranty that are used for commercial or industrial purposes default to a Two Year Warranty. Please contact Technical Service at 1-800-274-6846 for further clarification.

## How to Get Technical Support

Please contact Technical Service by calling 1-800-274-6846. **Please note that you will be asked to provide proof of initial purchase when calling.** If a product requires further inspection, the Technical Service representative will explain and assist with any additional action needed. JET has Authorized Service Centers located throughout the United States. For the name of an Authorized Service Center in your area call 1-800-274-6846 or use the Service Center Locator on the JET website.

## More Information

JET is constantly adding new products. For complete, up-to-date product information, check with your local distributor or visit the JET website.

## How State Law Applies

This warranty gives you specific legal rights, subject to applicable state law.

## Limitations on This Warranty

JET LIMITS ALL IMPLIED WARRANTIES TO THE PERIOD OF THE LIMITED WARRANTY FOR EACH PRODUCT. EXCEPT AS STATED HEREIN, ANY IMPLIED WARRANTIES OF MERCHANTABILITY AND FITNESS FOR A PARTICULAR PURPOSE ARE EXCLUDED. SOME STATES DO NOT ALLOW LIMITATIONS ON HOW LONG AN IMPLIED WARRANTY LASTS, SO THE ABOVE LIMITATION MAY NOT APPLY TO YOU.

JET SHALL IN NO EVENT BE LIABLE FOR DEATH, INJURIES TO PERSONS OR PROPERTY, OR FOR INCIDENTAL, CONTINGENT, SPECIAL, OR CONSEQUENTIAL DAMAGES ARISING FROM THE USE OF OUR PRODUCTS. SOME STATES DO NOT ALLOW THE EXCLUSION OR LIMITATION OF INCIDENTAL OR CONSEQUENTIAL DAMAGES, SO THE ABOVE LIMITATION OR EXCLUSION MAY NOT APPLY TO YOU.

JET sells through distributors only. The specifications listed in JET printed materials and on official JET website are given as general information and are not binding. JET reserves the right to effect at any time, without prior notice, those alterations to parts, fittings, and accessory equipment which they may deem necessary for any reason whatsoever. JET® branded products are not sold in Canada by JPW Industries, Inc.

## Product Listing with Warranty Period

90 Days – Parts; Consumable items; Light-Duty Air Tools
1 Year – Motors; Machine Accessories; Heavy-Duty Air Tools; Pro-Duty Air Tools
2 Year – Metalworking Machinery; Electric Hoists, Electric Hoist Accessories; Woodworking Machinery used for industrial or commercial purposes
5 Year – Woodworking Machinery
Limited Lifetime – JET Parallel clamps; VOLT Series Electric Hoists; Manual Hoists; Manual Hoist Accessories; Shop Tools; Warehouse & Dock products; Hand Tools

NOTE: JET is a division of JPW Industries, Inc. References in this document to JET also apply to JPW Industries, Inc., or any of its successors in interest to the JET brand.



# Warnings

1. Read and understand the entire owner's manual before attempting assembly or operation.
2. Read and understand warnings posted on the machine and in this manual. Failure to comply with all of these warnings may cause serious injury.
3. Replace warning labels if they become obscured or removed.
4. This band saw is designed and intended for use by properly trained and experienced personnel only. If you are not familiar with the proper and safe operation of a band saw, do not use until proper training and knowledge have been obtained.
5. Do not use this band saw for other than its intended use. If used for other purposes, JET disclaims any real or implied warranty and holds itself harmless from any injury that may result from that use.
6. Always wear approved safety glasses/face shields while using this machine. Everyday eyeglasses only have impact resistant lenses; they are not safety glasses.
7. Before operating this machine, remove tie, rings, watches, and other jewelry, and roll sleeves up past the elbows. Remove all loose clothing and confine long hair. Non-slip footwear is recommended. Do **not** wear gloves.
8. Wear ear protectors (plugs or muffs) during extended periods of operation (*Figure D*).
9. Some dust created by power sanding, sawing, grinding, drilling and other construction activities contain chemicals known to cause cancer, birth defects or other reproductive harm. Some examples of these chemicals are:
  - Lead from lead based paint.
  - Crystalline silica from bricks, cement and other masonry products.
  - Arsenic and chromium from chemically treated lumber.
10. Your risk of exposure varies, depending on how often you do this type of work. To reduce your exposure to these chemicals: work in a well-ventilated area and work with approved safety equipment, such as face or dust masks that are specifically designed to filter out microscopic particles.
11. Do not operate tool while tired or under the influence of drugs, alcohol or any other medication.
12. Make certain the switch is in the **OFF** position before connecting the machine to the power supply.
13. Make certain the machine is properly grounded.
14. Make all machine adjustments or maintenance with the machine unplugged from the power source.
15. Remove adjusting keys and wrenches. Form a habit of checking to see that keys and adjusting wrenches are removed from the machine before turning it on.
16. Keep machine guards in place at all times when the machine is in use. If removed for maintenance purposes, use extreme caution and replace the guards immediately.
17. Make sure the band saw is firmly secured to the floor before use.
18. Check damaged parts. Before further use of the machine, a guard or other part that is damaged should be carefully checked to determine that it will operate properly and perform its intended function – check for alignment of moving parts, binding of moving parts, breakage of parts, mounting, and any other conditions that may affect its operation. A guard or other part that is damaged should be properly repaired or replaced.

# Warnings

19. Provide for adequate space surrounding work area and non-glare, overhead lighting.
20. Keep the floor around the machine clean and free of scrap material, oil and grease.
21. Keep visitors a safe distance from the work area. **Keep children away.**
22. Make your workshop child proof with padlocks, master switches or by removing starter keys.
23. Give your work undivided attention. Looking around, carrying on a conversation and “horse-play” are careless acts that can result in serious injury.
24. Do **not** over reach. Maintain a balanced stance at all times so that you do not fall or lean against the drill bit or other moving parts.
25. Use the right tool. Don't force a tool or attachment to do a job for which it was not designed. The right tool will do the job better and safer at the rate for which it was designed.
26. Use recommended accessories; improper accessories may be hazardous.
27. Maintain tools with care. Keep tools sharp and clean for the best and safest performance. Follow instructions for lubricating and changing accessories.
28. Make sure the work piece securely attached or clamped to the table. Never use your hand to hold the work piece.
29. Never brush away chips while the machine is running. Use the correct speed and feed for the tool. Be sure that the tool is the correct one for your operation.
30. Never stand on a machine. Serious injury could occur if the machine tipped or if the drill bit is unintentionally contacted.
31. Never leave the machine running unattended. Turn the power off and don't leave the machine until it comes to a complete stop.



Familiarize yourself with the following safety notices used in this manual.

## **WARNING**

This means that if precautions are not heeded, it may result in serious injury or possibly even death.

## **CAUTION**

This means that if precautions are not heeded, it may result in minor or moderate injury and/or possible machine damage.

# Assembly

1. Disconnect the machine from the power source.
2. Unpack and clean all rust protected surfaces with a mild solvent or kerosene. Do not use paint thinner, lacquer thinner, or gasoline. These items will damage painted surfaces.
3. Turn cam locks to release the chuck.
4. Remove the chuck and place it on a piece of wood.
5. Clean the spindle nose and internal taper thoroughly.
6. Screw the coupling assembly into the spindle threads (Figure 1).

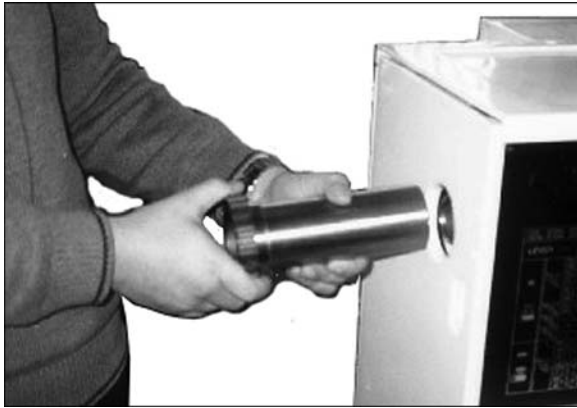

Figure 1

7. The runout on the coupling should be 0.005" or less. Adjustments can be made by three hex socket cap screws (A, Figure 2).

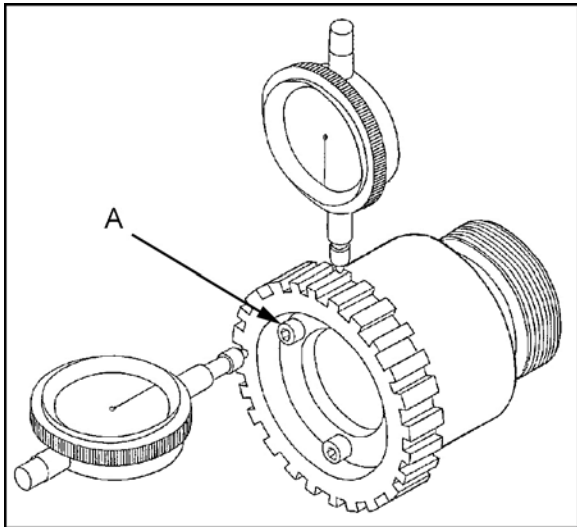

Figure 2

8. Thread the drawbar (B, Figure 3) into the collet closer assembly (C, Figure 3) until it is flush with the assembly.

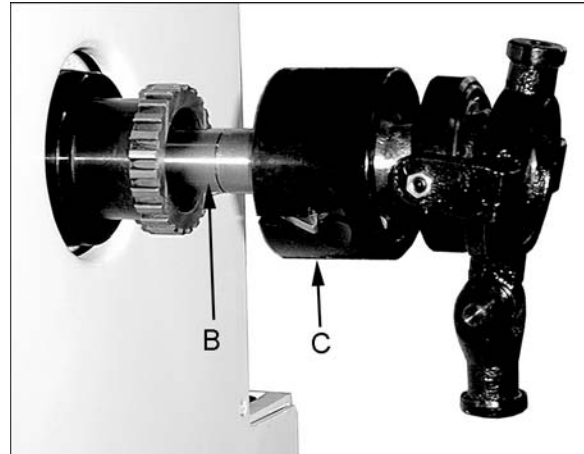

Figure 3

9. Slide collet closer assembly into spindle. Make sure it completely engages castled gear on the coupling.
10. Screw collet closer into collet by releasing collet closer lock and turning collet closer clockwise.

**Note:** It is necessary to push collet in while turning closer body to engage draw bar with the collet. Continue turning until the collet taper is seated (but not tensioned) in the taper.

11. Assemble all linkage and attach to collet closer body (Figure 4).

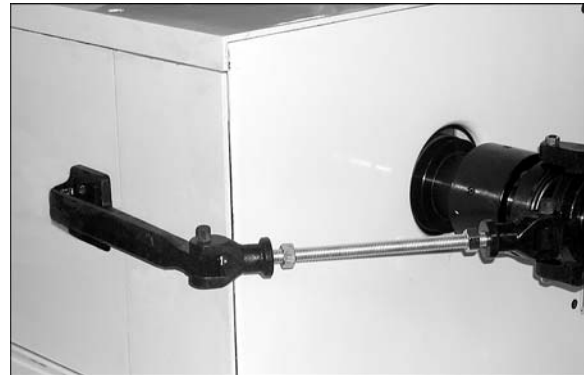

Figure 4

12. With the help of another person, hold the collet closer in position with the fixed seat against the headstock.

**Note:** The bearing shaft should be centered in the bearing body.

13. Once the location of the fixed seat has been determined, use a transfer punch to mark the location of four mounting holes.

14. Drill four pilot holes with a smaller bit (0.136"). Drill four appropriate sized holes with a 0.203" drill bit.

**Caution: Do not drill through headstock! Mark the drill bit so that you do not exceed 0.5".**

15. Tap drilled holes with a 1/4"-20 plug tap. Finish the holes with a 1/4"-20 tap.

16. Install fixed seat to headstock with four 1/4"-20 x 3/4" hex socket cap screws.

17. Connect all linkage and adjust for proper operation.

18. Place a cutter or material into the collet so you can adjust the outward flange. Turn the outward flange until you can move the lever and it "pops" into place locking the cutter or material into the collet.

## Replacement Parts

### Ordering Information

Replacement parts are listed on the following pages. To order parts or reach our service department, call 1-800-274-6848 Monday through Friday, 8:00 a.m. to 5:00 p.m. CST. Having the Model Number and Serial Number of your product available when you call will allow us to serve you quickly and accurately.

CC-BDB1340A Collet Closer – Exploded View

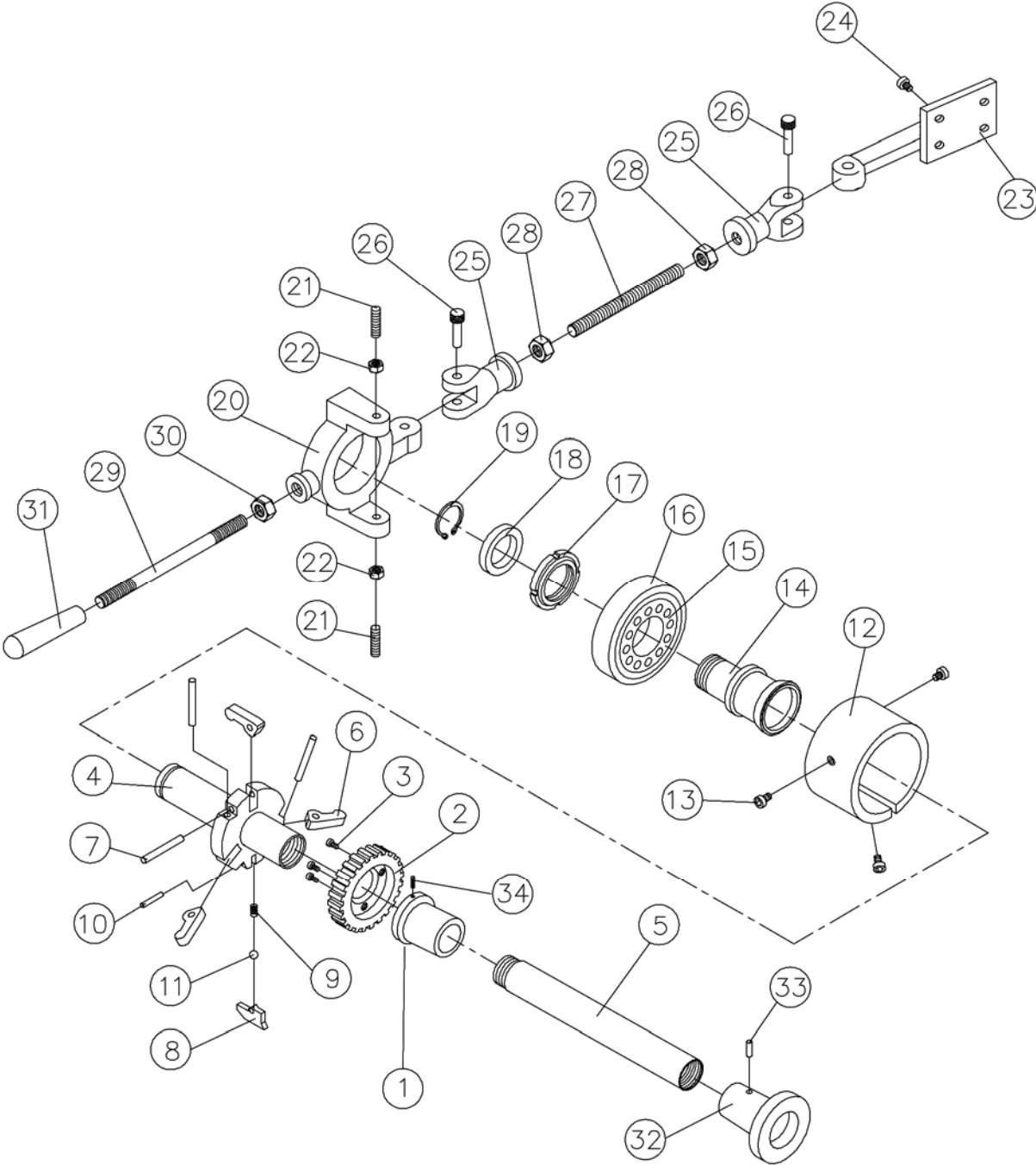

## CC-BDB1340A Collet Closer – Parts List

Index No.	Part No.	Description	Size	Quantity
1	CC13BD-01A	Sleeve Coupling	85mm	1
2	CC13BD-02	Coupling		1
3	CC13BD-03	Hex Socket Cap Screw		3
4	CC13BD-04	Arbor		1
5	CC-05BJ	Draw Bar	390mm	1
6	CC13BD-06	Buckle		3
7	CC13BD-07	Pin		3
8	CC13BD-08	Buckling Plate		1
9	CC13BD-09	Spring		1
10	CC13BD-10	Pin		1
11	CC13BD-11	Steel Ball		1
12	CC13BD-12	Outward Flange		1
13	CC13BD-13	Hex Socket Cap Screw		3
14	CC13BD-14	Bearing Shaft		1
15	CC13BD-15	Ball Bearing		1
16	CC13BD-16	Bearing Stand		1
17	CC13BD-17	Locking Nut		1
18	CC13BD-18	Collar		1
19	CC13BD-19	Retaining Ring (external)		1
20	CC13BD-20	Bearing Body		1
21	CC13BD-21	Set Screw		2
22	CC13BD-22	Hex Nut		2
23	CC-23LN	Fixed Seat	200L	1
24	CC13BD-24	Hex Socket Cap Screw		4
25	CC13BD-25	Coupling		2
26	CC13BD-26	Special Pin		2
27	CC13BD-27	Screw Bolt		1
28	CC13BD-28	Hex Nut		2
29	CC13BD-29	Screw Bolt		1
30	CC13BD-30	Hex Nut		1
31	CC13BD-31	Grip		1
32	CC13BD-32	Sleeve		1
33	CC13BD-33	Pin		1
34	CC13BD-34	Set Screw	M6x8	1



427 New Sanford Road  
 LaVergne, Tennessee 37086  
 Phone: 800-274-6848  
[www.jettools.com](http://www.jettools.com)