

**Option X02 Hand Crank**  
Serial number 0316 to \_\_\_\_ (MMYY)

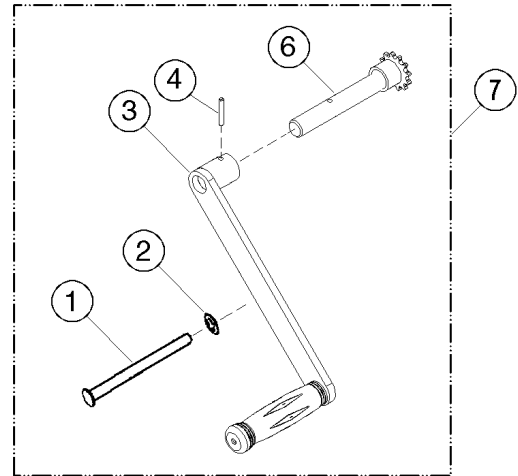

ITEM #	QTY.	PART #	DESCRIPTION
1	1	100-P	STOP PIN, HAND CRANK, 1/2 X 5
2	1	718-P	NUT, PUSH, 1/2"
3	1	5U-P	HAND CRANK, W/ SOCKET TUBE
4	1	64-P	ROLL PIN, 3/16 X 1-1/4
6	1	5135-P	SHAFT, 12T SPROCKET & SPACER
7	1	1460-P	CRANK KIT, SIMPLE, W/ 12T

**Option X03 Hand Wheel**  
Serial number 0316 to \_\_\_\_ (MMYY)

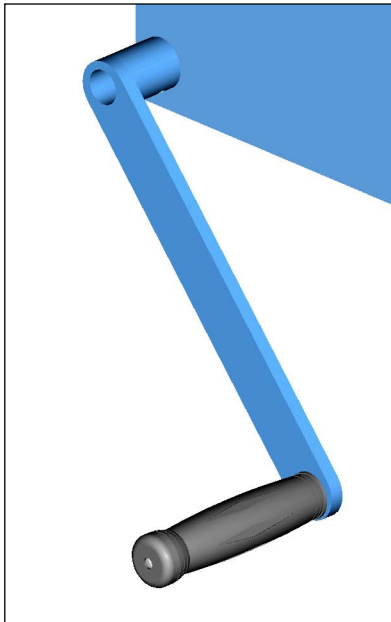
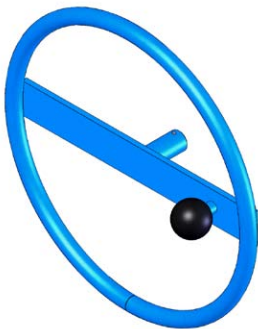

Part # 2685-P  
16" Hand Wheel



Part # 2813-P  
10" Hand Wheel

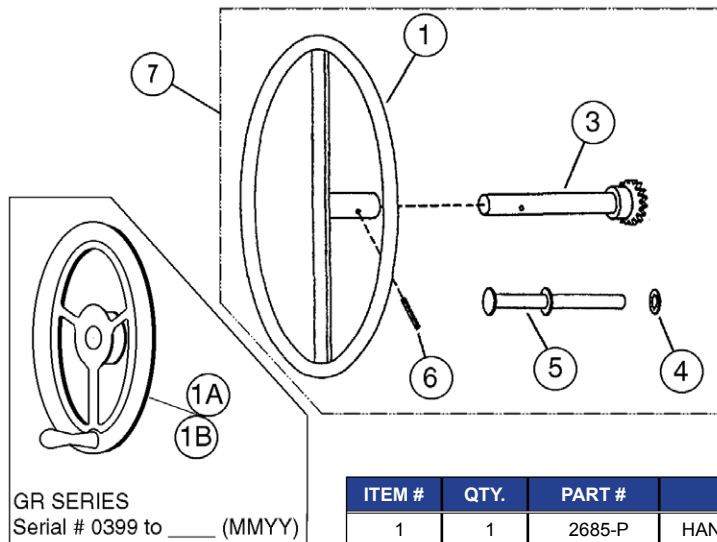

GR SERIES  
Serial # 0399 to \_\_\_\_ (MMYY)

ITEM #	QTY.	PART #	DESCRIPTION
1	1	2685-P	HANDWHEEL 16" 3/4B w/ KNOB
1A	1	2813-P	HANDWHEEL, 10", 185GR, 3/4"
1B	1	5034-P	HANDWHEEL, 8", 285GR, 5/8"
3	1	5135-P	SHAFT, 12T SPROCKET & SPACER
4	1	718-P	NUT, PUSH, 1/2"
5	1	101-P	STOP PIN, HANDWHEEL, 1/2"
6	1	64-P	ROLL PIN, 3/16 X 1-1/4
7	1	2690-P	KIT, 16" DIA HANDWHEEL, W/ 12T