

Contents	Page
Parts List and Diagram. . . . .	1
Installation Instructions. . . . .	1
Operating Instructions. . . . .	2

**Operator's Manual**  
**for Morse Rim Clamp Assembly Kit**

**Kit # 4560-P**  
**Serial number 0615 to \_\_\_\_ (MMYY)**

**IMPORTANT NOTE**  
4-Digit serial numbers are simply the month & year of manufacture  
Example: 0802 is August 2002

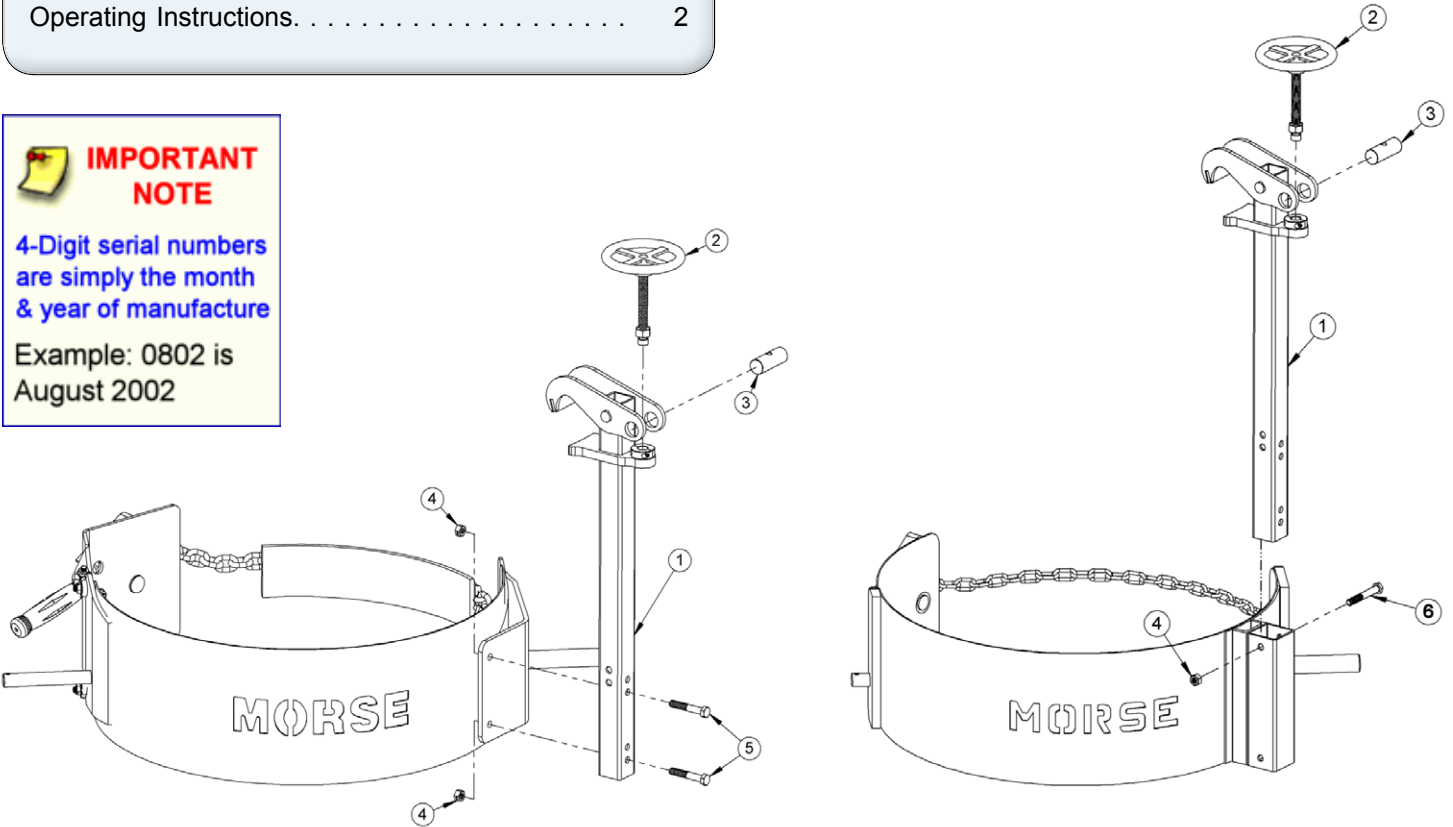

**INSTALLATION INSTRUCTIONS**  
**for MORcinch Drum Holder**

1. Position Rim Clamp Assembly (item 1) on drum holder bracket with holes aligned.
2. Bolt in place using 2 bolts (item 5) and 2 nuts (item 4).

**INSTALLATION INSTRUCTIONS**  
**for Drum Holder with Socket Tube**

1. Slide Rim Clamp Assembly (item 1) down through socket tube, and line up top holes in Rim Clamp Assembly with top holes of socket tube.
2. Use bolt (item 6) and nut (item 4) to bolt in place through the top holes of the socket tube and the Rim Clamp Assembly.

ITEM	QTY	PART #	DESCRIPTION
1	1	5806-P	WELD, RIM CLAMP
2	1	3616-P	HANDWHEEL ASM, 4", 3540-P 185R
3	1	3510-P	THREADED BARREL, RIM CLAMP
4	2	1169-P	NUT, 3/8-16 REV HEX LOCK
5	2	82-P	HHCS, 3/8-16 X 2-1/4 GR2
6	1	1315-P	HHCS, 3/8-16 X 2-3/4 GR2

**Operator's Manual for Morse Rim Clamp Assembly Kit - Part # 4560-P**  
**Serial Number 0615 to \_\_\_\_ (MMYY)**

**OPERATING INSTRUCTIONS**

**TO SECURE DRUM:**

1. Turn hand wheel (item 2) counter clockwise to open top jaw.
2. Position drum holder assembly with bottom jaw of rim clamp directly under top rim of drum.
3. Turn hand wheel clockwise until top jaw is pressing tightly against top of drum (see Figure 1).
4. Secure drum with chain and ratchet mechanism. Drum is now ready to be lifted and tilted.

**TO RELEASE DRUM:**

1. Lower drum to floor in an upright position.
2. Release chain from ratchet mechanism by applying pressure to ratchet handle in a clockwise direction with one hand and opening pawl to free ratchet with other hand. Remove chain link from ratchet.
3. Open rim clamp by turning hand wheel counter clockwise.

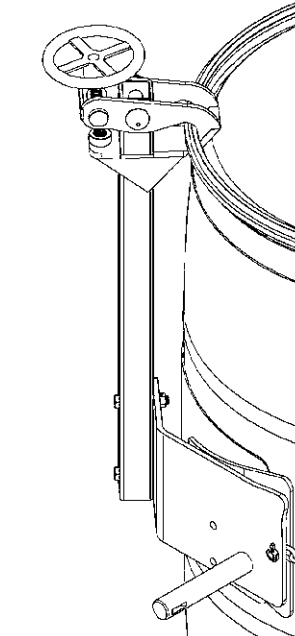

**Figure 1**  
Plastic drum being lifted with  
Rim Clamp Assembly Kit  
installed.