

QF Floor Sweep 3248

Size (ID) In.	ID In.	Rolled Edge (nom. in.)	Std Weight Lbs	GS	304SS (or 316SS)
				20ga	20ga
3	2.90	0.2	5.80	Std	Optional
4	3.86	0.2	6.90		
5	4.86	0.2	7.30		
6	5.89	0.2	7.55		
7	6.89	0.3	7.75		
8	7.88	0.3	8.25		
9	8.88	0.3	9.50		
10	9.89	0.3	11.75		
11	10.88	0.3	13.20		
12	11.97	0.4	15.70		

Construction

Body: lapped, spot welded and caulked.

Collars: have a laser welded longitudinal seam. Collars are attached to the body using a raised hemmed, spot welded seamed construction and are caulked.

Door: 16ga.

Ends: Standard QF end can be changed to Raw ID (RAWID), Raw OD (RAWOD), No Fitting (NF), Hose Adapter (RAWFLEX), Flat Flange (FFL), Angle Flange (ANGFL), or Van Stone (VANSTONE).

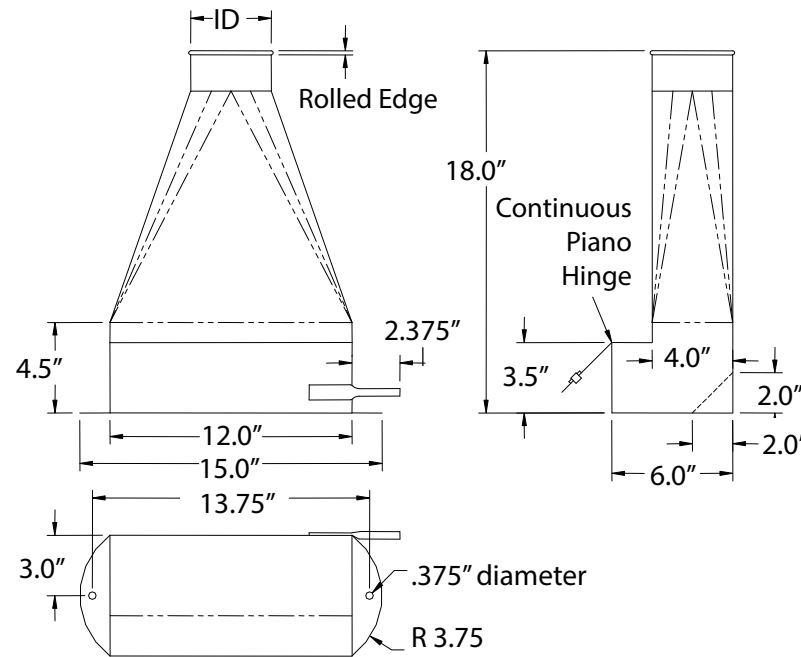

QF Floor Sweep 3248

Temperature Rating of Product Components					
° F	QF Floor Sweep		Sealants		
1100°	Galvanized Steel	Optional - 304SS	3M Scotch Seal Metal Sealant 2084	Optional - 3M Polyurethane Adhesive Sealant 560	Optional - Rock River Silicone Sealant
500°					
400°					
390°					
250°					
194°					
0°					
-40°					
-60°					

Additional Notes
At temperatures ranging between 390° F and 480° F, the zinc-iron alloy layers in galvanized steel will continue to provide a high level of protection from corrosion. However, there may be some peeling, changes in mechanical properties, and reduction in the corrosion protection. Recommended max. service temperature is 390° F.
Rock River Silicone Sealant and Red Devil HVAC/R High Temperature Silicone Sealant are not paintable
304SS: bluing may occur at 800° F and above

Compliance / Rating of Product Components		
Product	Material	Compliance / Rating
QF Floor Sweep	Galvanized	ASTM A527 with a G-90 rating
	304SS	Finish meets ASTM A240
	316SS	Finish meets ASTM A240
3M Scotch Seal Metal Sealant 2084	Acetone blend	AAMA Specification 801.1
3M Polyurethane Sealant 560	Polyurethane	ASTM E 162, ASTM E 662, Bombardier SP 800-C
Rock River Sealant	100% Silicone	ASTM C920 Class 25, TT-S-00230C Class A and TT-S-001543A, FDA No 421 CFR 117.2600, conforms to FDA requirements
Red Devil HVAC/R High Temperature Sealant	Silicone	ASTM C920 Class 25, TT-S-00230C Class A and TT-S-001543A, CEBTP 432.6 140-2, Mil Spec 46106A, CGSB 19C9-9B, DIN 18540 Part 2, OREX 150031-2