

QF Butterfly Valve 3208

Size In.	Minimum Raw End ID In.	Rolled Edge (nom. in.)	Length In.	Std Weight Lbs	Galvanized Steel			304SS (or 316SS)	
					22ga	20ga	18ga	22ga	20ga
3	3.16	0.2	8	1.50	Std			Std	
4	3.96	0.2	8	1.65					
5	4.96	0.2	8	2.00					
6	5.99	0.2	8	2.40					
7	7.00	0.3	8	3.20					
8	8.00	0.3	13	4.10					
9	9.00	0.3	13	4.85					
10	10.00	0.3	13	5.45					
11	11.12	0.3	13	7.00					
12	12.11	0.4	13	8.40					
13	13.12	0.4	17	9.75			Optional		
14	14.10	0.4	17	11.85					
15	15.12	0.4	17	12.70					
16	16.10	0.4	17	14.20					
17	17.07	0.4	23	16.10					
18	18.10	0.4	23	18.00					
19	19.10	0.4	23	22.50					
20	20.10	0.4	23	27.75					
21	21.10	0.4	23	30.00					
22	22.11	0.4	23	32.40					
23	23.11	0.4	23	37.50					
24	24.06	0.4	23	37.90					

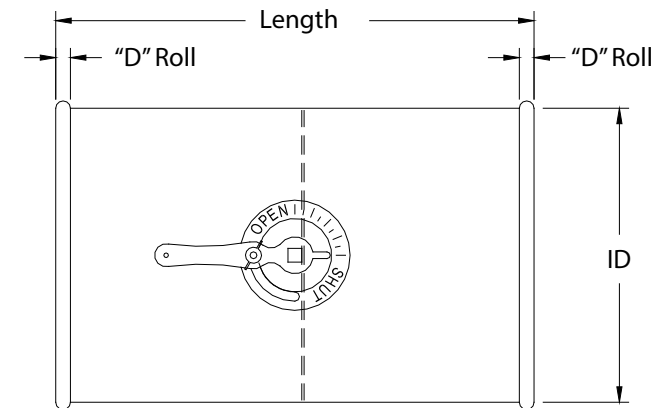

Construction

Seam: longitudinal seam is laser welded.

Shaft: 3/8" square rod.

Note: Standard QF end can be changed to Raw ID (RAWID), Raw OD (RawOD), No Fitting (NF), Hose Adapter (RAWFLEX), Flat Flange (FFL), Angle Flange (ANGFL).

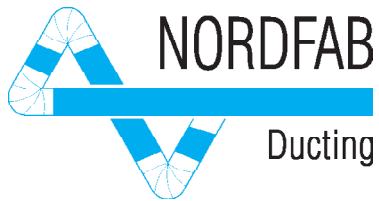

QF Butterfly Valve 3208

TECHNICAL DATA

Temperature Rating of Product Components						
° F	QF Butterfly Valve		Grommet	Sealants		
225°	Galvanized Steel	Optional - 304SS	Styrene Butadiene Rubber, durometer hardness 60	3M Scotch Seal Metal Sealant 2084	Optional - Rock River Silicone Sealant	Optional - Red Devil HVAC/R High Temperature Silicone Sealant
194°						
-40°						
-60°						
						Optional - Epoxy - 3M DP 125 Gray Sealant

Additional Notes

At temperatures ranging between 390° F and 480° F, the zinc-iron alloy layers in galvanized steel will continue to provide a high level of protection from corrosion. However, there may be some peeling, changes in mechanical properties, and reduction in the corrosion protection. Recommended max. service temperature is 390° F.

Rock River Silicone Sealant and Red Devil HVAC/R High Temperature Silicone Sealant are **not paintable**

Compliance / Rating of Product Components		
Product	Material	Compliance / Rating
QF Butterfly Valve	Galvanized	ASTM A527 with a G-90 rating
	304SS	Finish meets ASTM A240
	316SS	Finish meets ASTM A240
3M Scotch Seal Metal Sealant 2084	Acetone blend	AAMA Specification 801.1
Rock River Sealant	100% Silicone	ASTM C920 Class 25, TT-S-00230C Class A and TT-S-001543A, FDA No 421 CFR 117.2600, conforms to FDA requirements
Red Devil HVAC/R High Temperature Sealant	Silicone	ASTM C920 Class 25, TT-S-00230C Class A and TT-S-001543A, CEBTP 432.6 140-2, Mil Spec 46106A, CGSB 19C9-9B, DIN 18540 Part 2, OREX 150031-2

Additional Product Components and Notes		
Quadrant (3/8" dial regulator)	Butterfly Valve Size	Mfr. Part No. (Duro Dyne)
	3" - 11" galvanized	KSR195L
	12" - 24" galvanized	KS385
	All SS	KR3SS

