

QF Adjustable Nipple

3202

Size In.	ID In.	Rolled Edge (nom. in.)	Length In.	Std Weight Lbs	Galvanized Steel			304SS (or 316SS)				
					22ga	20ga	18ga	22ga	20ga			
3	3.16	0.2	11.25	0.80	Standard		Optional	Standard	Optional			
4	3.96	0.2	11.375	1.05								
5	4.96	0.2	11.375	1.30								
6	5.99	0.2	11.375	1.6								
7	7	0.3	11.125	2.4								
8	8	0.3	11.125	2.7								
9	9	0.3	11.125	3.05								
10	10	0.3	11.125	3.4								
11	11.12	0.3	11.125	3.8								
12	12.11	0.4	10.875	4.2						Optional		
13	13.12	0.4	10.875	4.7								
14	14.1	0.4	10.875	5.85								
15	15.12	0.4	10.875	6.25								
16	16.1	0.4	10.875	6.65								
17	17.07	0.4	10.875	7.45	Standard			Standard				
18	18.1	0.4	10.875	7.45								
20	20.1	0.4	10.875	8.1								
22	22.11	0.4	10.875	8.8								
24	24.06	0.4	10.875	9.7								

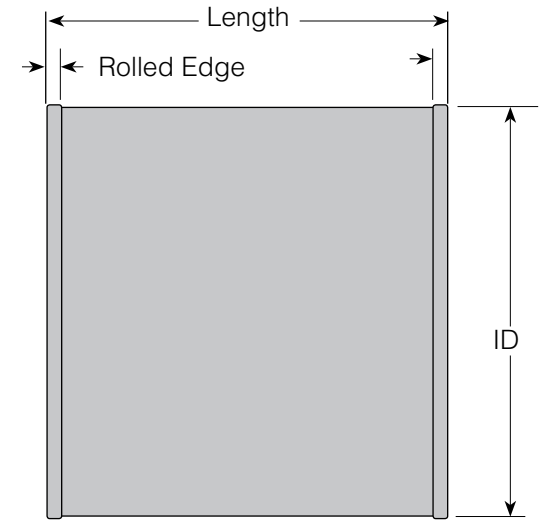

Construction

Seam: longitudinal seam is laser welded.

QF Adjustable Nipple 3202

Temperature Rating of Product Components								Additional Notes
° F	QF Adjustable Nipple		O-rings		Sealants			
1100°	Galvanized Steel	Optional - 304SS	Black included as standard	Optional - Red**	3M Scotch Seal Metal Sealant 2084	Optional - Rock River Silicone Sealant	Optional - Red Devil HVAC/R High Temperature Silicone Sealant	<p>At temperatures ranging between 390° F and 480° F, the zinc-iron alloy layers in galvanized steel will continue to provide a high level of protection from corrosion. However, there may be some peeling, changes in mechanical properties, and reduction in the corrosion protection. Recommended max. service temperature is 390° F.</p> <p>Rock River Silicone Sealant and Red Devil HVAC/R High Temperature Silicone Sealant are not paintable</p> <p>304SS: <ul style="list-style-type: none"> • 3" - caulking on collared seam only • bluing may occur at 800° F and above </p>
500°								
450°								
390°								
250°								
194°								
0°								
-40°								
-60°								
-75°								

** Red O-ring for higher temps - Order separately and replace on-site

Compliance / Rating of Product Components		
Product	Material	Compliance / Rating
QF Adjustable Nipple	Galvanized	ASTM A527 with a G-90 rating
	304SS	Finish meets ASTM A240
	316SS	Finish meets ASTM A240
3M Scotch Seal Metal Sealant 2084	Acetone blend	AAMA Specification 801.1
Rock River Sealant	100% Silicone	ASTM C920 Class 25, TT-S-00230C Class A and TT-S-001543A, FDA No 421 CFR 117.2600, conforms to FDA requirements
Red Devil HVAC/R High Temperature Sealant	Silicone	ASTM C920 Class 25, TT-S-00230C Class A and TT-S-001543A, CEPTP 432.6 140-2, Mil Spec 46106A, CGSB 19C9-9B, DIN 18540 Part 2, OREX 150031-2
O-ring, black	Buna-N	60 Duro-Meter hardness
O-ring, red	Silicone rubber	ZZ-R-765 Class 2A and 2B grade 70 AMS-3304E and 3304F and 3303G, FDA approved