

CAUTION

- Hazardous Voltage! Disconnect all electrical power, including remote disconnects before servicing. Follow proper lockout/tagout procedures to ensure the power cannot be inadvertently energized. Failure to disconnect power before servicing could result in death or serious injury.
- Use copper wire only, insulate or wire nut all unused leads.
- Care should be used to avoid electrostatic discharge to the thermostat.

SPECIFICATIONS

Input Power: NEC Class 2, 18-32 VAC 50/60, 24 VAC nominal 1 VA max
 Communication Jack: Accessible through bottom of cover
 Operating Temperature: 32 to 120°F (-0° to 49°C)
 Shipping Temperature: -4° to 130°F (-20° to 54°C)
 Operating Humidity: 5 to 95% non-condensing
 Physical Dimensions: 2.8 x 4.5 x 1.2 (71.1 x 114.3 X 27.8 mm) including button heights
 Mounting: Vertically flush mount or mount on standard (50.8 X 101.6mm) 2x4 in (71.1 x 114.3 x 27.8 mm) device
 Compatibility: Compatible with TRANE™ unit control modules (UCM)

WIRING DIAGRAM

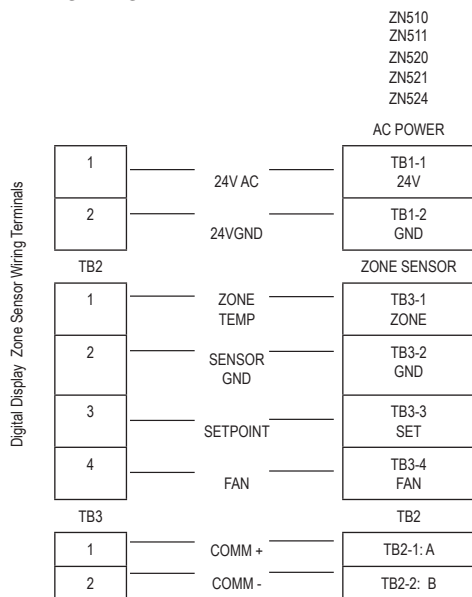

***Note: Wiring backwards will result in product failure.**

PRE-INSTALLATION NOTES

1. All wiring must be in accordance with NEC and local building codes.
2. Do not run low-voltage wiring in the same conduit with high-voltage power wiring.
3. Sharing the 24V Class 2-power source from the UCM is the preferred practice and simplifies installation. See wiring diagram above and wiring requirements under item 4 at right. Use caution to be sure 24V and GND are connected to the proper terminals when connecting to the UCM.
4. If a separate 24V Class 2 power source is used to power the Digital Zone Sensor, terminals TB1-2 (24V GND) and TB2-2(Sensor GND) must be jumpered together at the sensor for the sensor to operate. However, the usage of a transformer, with the supply voltage greater than 150V to ground as the separate 24V Class 2 power source is not recommended because its output should be grounded to building ground (following NEC requirements for Class 2 devices.) This additional grounding can affect the operation and/or damage the Digital Zone Sensor.
5. The sensor display will not be enabled with 24V connection only. Sensor signal wiring to the UCM must be connected for the display to function.
6. Sensor must be connected to a UCM and powered up for at least 1 hour to achieve maximum accuracy.
7. "Sensor setpoint" output cannot be verified with an ohm meter. Connection to a UCM is necessary to verify operation.
8. Plug holes through the wall behind the sensor to prevent undesirable airflow.

WARNING

- READ THESE INSTRUCTIONS CAREFULLY BEFORE ATTEMPTING TO INSTALL, OPERATE OR SERVICE THIS THERMOSTAT.
- Failure to observe safety information and comply with instructions could result in PERSONAL INJURY, DEATH AND/OR PROPERTY DAMAGE.
- To avoid electrical shock or damage to equipment, disconnect power before installing or servicing and use only wiring with insulation rated for full thermostat operating voltage.
- To avoid potential fire and/or explosion do not use in potentially flammable or explosive atmospheres.
- Retain these instructions for future reference. This product, when installed, will be part of an engineered system whose specifications and performance characteristics are not designed or controlled by PECO. You must review your application and national and local codes to assure that your installation will be functional and safe.

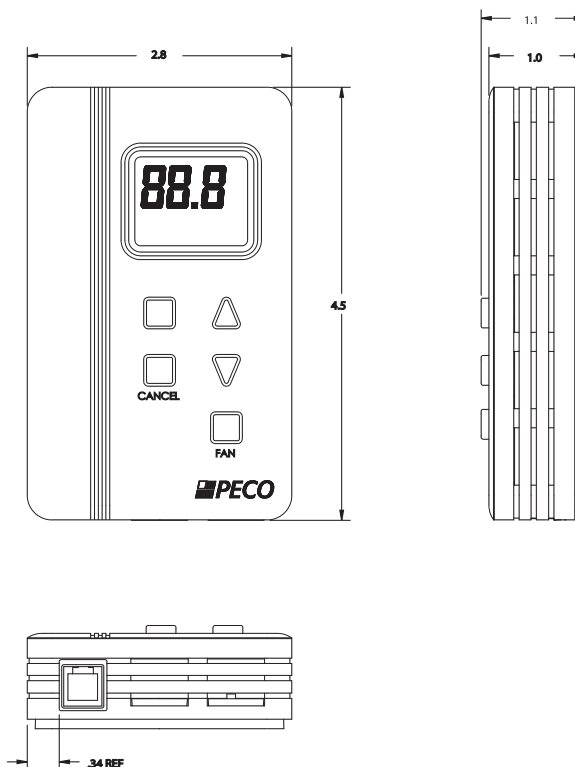

2. **Remove cover.** Remove zone sensor cover by easing the tip of a small screwdriver into the top rear center slot closest to the wall. Gently move the top of the screwdriver towards you. Excessive force is not recommended for cover removal.
3. **Mount base.** Remove zone sensor cover from base and mount on wall or 2X4 device box.
4. **Connect Wires.** Connect wires as shown in the wiring diagram. For wire lengths less than 75 feet, an 18 gage, 5 or 6 conductor cable may be used. For wire lengths greater than 75 feet, use 18 gage, 2 conductor cable for the power wiring (TB1), and 18 gage, 3 conductor cable for signal wiring (TB2). Avoid routing wires near sources of electrical noise such as motors, fluorescent lights, LAN wiring, etc. In some high-noise environments, signal wires may require shielding. The communication jack should be wired with the cable appropriate for the system being installed.
5. **Replace Cover.** Place zone sensor cover back on the base and snap securely into place.

OPERATING INSTRUCTIONS

Idle Display

- No action
 - ◇ Continuously displays the current zone temperature or setpoint

Change setpoint

- Repeatedly press UP or DOWN arrow button
 - ◇ SETPOINT flashes
 - ◇ Display increases or decreases
 - ◇ Release and system returns to the idle display

Begin Timed Override

- Press and hold the ON button until OVERRIDE appears
 - ◇ Timed override begins
 - ◇ System shows the idle display and OVERRIDE

Cancel Timed Override

- Hold CANCEL button until OVERRIDE disappears
 - ◇ Timed override is cancelled
 - ◇ System returns to the idle display

Change Fan Mode

- Press FAN button
 - ◇ Active Fan Mode flashes
 - ◇ Press UP or DOWN arrow button to change

SERVICE INSTRUCTIONS

Change display units (°F/°C)

- Hold UP and DOWN arrow buttons until screen goes blank
- Release buttons
 - ◇ Display shows °F and °C (current unit flashing)
- Press UP or DOWN button to select °F and °C
 - ◇ Selected unit begins flashing
 - ◇ System returns to the idle display

Change idle display from room temperature display to continuous setpoint display mode

- Hold UP and DOWN arrow buttons until screen goes blank
- Release buttons
 - ◇ Display shows °F and °C (current unit flashing)
- Hold UP and DOWN arrow buttons until screen goes blank
- Release buttons
 - ◇ Display shows °F and °C (not flashing)
- Press UP or DOWN arrow buttons
 - ◇ SETPOINT flashes
 - ◇ Display times out and returns in the continuous setpoint display mode

Adjust the setpoint offset

- Hold UP and DOWN arrow buttons until screen goes blank
- Release buttons
 - ◇ Display shows °F and °C (current unit flashing)
- Hold UP and DOWN arrow buttons until screen goes blank
- Release buttons
 - ◇ Display shows °F and °C (not flashing)
- Hold UP and DOWN arrow buttons until screen goes blank
- Release buttons
 - ◇ Display shows the setpoint adjust mode
- Hold UP and DOWN arrow buttons
 - ◇ Setpoint offset value changes
 - ◇ System returns to the idle display

Adjust the room temperature display offset

- Hold UP and DOWN arrow buttons until screen goes blank
- Release buttons
 - ◇ Display shows °F and °C (current unit flashing)
- Hold UP and DOWN arrow buttons until screen goes blank
- Release buttons
 - ◇ Display shows °F and °C (not flashing)
- Hold UP and DOWN arrow buttons until screen goes blank
- Release buttons
 - ◇ SETPOINT flashes
 - ◇ Display shows the setpoint adjust mode
- Hold UP and DOWN arrow buttons until screen goes blank
- Release buttons
 - ◇ Display shows temperature offset display
- Press UP or DOWN arrow buttons
 - ◇ Temperature offset value changes
 - ◇ System returns to the current display mode