

Installation Instructions

INSTALLATION

1. Install the T168 with the two furnished mounting screws to a standard 4 1/16" x 2 1/8" square device box with a 2" x 4" adapter ring.
2. For wall installations, mount the thermostat on an inside wall approximately 5 feet above the floor. The locations should provide circulation at an average room temperature. Avoid direct sunlight or sources of hot or cold air in the room.
3. Remove the cover. Mount thermostat base assembly to the outlet box using screws provided. Tighten the screws evenly but do not overtighten. Connect wires per wiring diagram.
4. To use a remote sensor on units with local sensing capability, remove jumper JP-1 to disable local sensing. Failure to remove JP-1 will cause improper operation of thermostat.
5. Connecting a jumper between terminals 16 and 17 will disable the secondary output and change the main output to heat mode.
6. Connection of a 24 VAC set back signal will force the control into unoccupied mode (see diagram). Pressing an arrow key or the mode buttons on the thermostat cover will disable the setback input for one hour.
7. Remove the LCD plastic protective film to complete the installation. Reinstall the cover assembly. Install cover locking screw provided.
8. Checkout: After wiring and installation are complete, energize the system and check the operation. Adjust the thermostat as necessary to complete at least one cycle. Be sure the thermostat and all other equipment are functioning correctly.



CAUTION

- Use Copper wire only, insulate or wire nut all un-used leads.
- Care should be used to avoid electrostatic discharge to the microprocessor.
- This unit has configuration dip switches and jumpers. You may need to reconfigure thermostat for your application.

MOUNTING

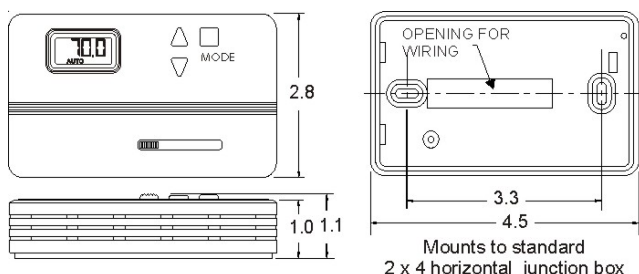

WARNING

- READ THESE INSTRUCTIONS CAREFULLY BEFORE ATTEMPTING TO INSTALL, OPERATE OR SERVICE THIS THERMOSTAT.
- Failure to observe safety information and comply with instructions could result in PERSONAL INJURY, DEATH AND/OR PROPERTY DAMAGE.
- To avoid electrical shock or damage to equipment, disconnect power before installing or servicing.
- To avoid electric shock or damage to equipment, use only wiring with insulation rated for full thermostat operating voltage.
- To avoid potential fire and/ or explosion do not use in potentially flammable or explosive atmospheres.
- Retain these instructions for future reference. This product, when installed, will be part of an engineered system whose specifications and performance characteristics are not designed or controlled by PECO, Inc. You must review your application and national and local codes to assure that your installation will be functional and safe.

WIRING DIAGRAM

TYPICAL WIRING

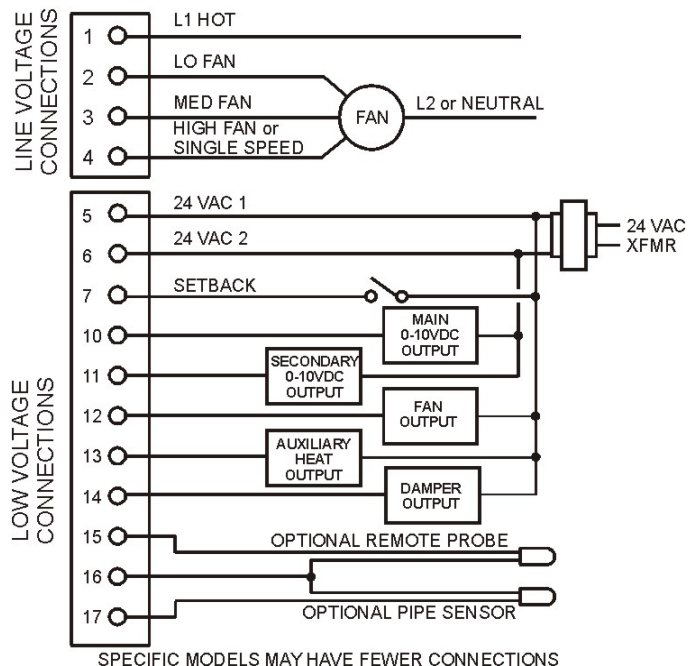

ELECTRICAL RATING

ELECTRICAL RATINGS					
Fan Switch (Terminals 1-4) Line Voltage Connections					
Voltage	Inductive		Resistive	Pilot	Thermostatic Switching/ Low Voltage
	FLA	LRA			
24 VAC	N.A.	N.A.	N.A.	24 VA	10 VA
120	5.8	34.8	6.0	125 VA	N.A.
240	2.9	17.4	5.0	125 VA	N.A.
277	2.4	14.4	4.2	125 VA	N.A.

APPLICATION NOTES

1. When no changeover pipe sensor is used, the main output controls cooling and the secondary output controls heating.
2. The fan output, terminal 12, is energized whenever there is a demand for heating or cooling. This output can be connected to a relay that can be used to provide fan cycling to terminal 1.
3. The changeover pipe sensor should be mounted on the main coil input for water system operation and in the main duct system for forced air operation.
4. The set point and operating mode will be retained on a loss of power.
5. When using either a remote probe or pipe sensor, run wiring away from any electrical motors or power wiring.
6. The auxiliary heat output supplies a 24 VAC signal with call for heat. This output is shipped configured for staged heat.
7. The thermostat is shipped with all dip switches in the "ON" (closed) position.
8. The damper output is ON when mode is AUTO, HEAT or COOL, damper is OFF in set back.

THERMOSTAT OPERATION

These thermostats are designed to control 0-10 VDC/4-0 mA valves. These units may include a fan switch with one or more fan speed selections.

MODE BUTTON OPERATION

OFF All thermostat outputs are off, fan is still operational if connected to a manual fan switch.

AUTO The thermostat automatically selects heating or cooling mode depending upon the relationship of the setpoint and the room temperature. The appropriate HEAT or COOL indicator is enabled in addition to AUTO. A 3°F dead band is provided to prevent short cycling between heating and cooling modes. After changeover, the control points automatically shift so that the heating off point equals the set point temperature or the cooling off point equals the set point temperature.

COOL The thermostat operates as a cooling only thermostat. The heating outputs are disabled.

HEAT The thermostat operates as a heating only thermostat. The cooling outputs are disabled.

FAN SPEED SWITCH OPERATION

Fan speed is determined by manual selection from fan switch OFF to HIGH, MEDIUM and/or LOW. In the OFF position all outputs are off and the display is blank.

UP/DOWN ARROW OPERATION

A first touch of either arrow will display the setpoint (a single set point is employed for both heating and cooling). Continued pressure on either arrow will scroll the setpoint to new values. After three consecutive seconds on either arrow, the selected setpoint becomes effective and the display of the room temperature resumes.

CONFIGURATION

CIRCUIT BOARD JUMPER CONFIGURATION		
Jumper Designation	Closed ON*	Open OFF
JP1	Local Sensing	Remote Sensing
JP2	2 Pipe System	4 Pipe System
JP3	Factory Use Only	
JP4	0-10 VOC Main Output	4-20 mA Main Output
JP5	0-10 VOC Secondary Output	4-20 mA Secondary Output

DIP SWITCH CONFIGURATION		
Switch Designation	Closed On*	Open Off
1	Not Used	Not Used
2	Staged Heat 3°F Diff. (Term. 13)	Aux. Heat No Diff. (Term. 13)
3	F Display	C Display
4	Main & Sec. Outputs 0-10 VOC (Term. 10 & 11) requires JP4 & JP5	Main & Sec. Outputs 4-20 mA (Term. 10 & 11) Remove JP4 & JP5
5	Operating Position	Not Used
6	Setback= 90°F & 50°F	Setback = 85°F & 60°F

* On is with the dip switch handle to the right-see diagram below

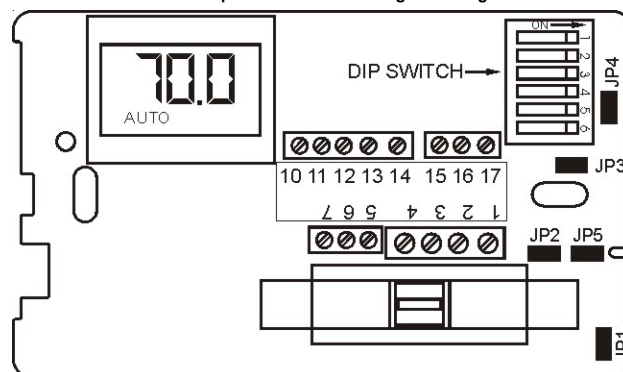

Service Menu:

Access: Press UP and DOWN arrows for 5 seconds.

Menu Selection: Select 1 to 5 by pressing the mode button or by pressing the UP and DOWN arrows simultaneously.

Adjust Value: Use UP or DOWN arrow.

Item #	Function	Range	Default
1	Zone Temp Offset	-5.1F to 5.1F	0F
2	Valve Stroke Time	30 sec. To 5 min.	120 sec.
3	Fan Delay to OFF	2 to 10 Minutes	120 Sec.
4	Compressor Minimum Off Time	30 Sec. To 10 min.	120 Sec.
5	Purge Cycle	0 = Time Based 1 = Temperature Based	1

