

LBK10

Linebacker® Surge Protector



LBK10

SURGE PROTECTOR

GREEN INDICATOR

ON: Protected
OFF: Not Protected; Replace Unit

CONT. FLASH: 3 Minute Start Delay
1 FLASH: Over Voltage
2 FLASHES: Under Voltage
3 FLASHES: Lost Neutral or Ground

Type 2 SPD
Voltage: 120/208/240 VAC
Frequency: 60 Hz
I: 10 kA, SCCR: 10kA
MCOV: L-N 150 V; L-L 300 V
VPR: L-N/G 600 V; L-L 1000 V
UL 1449 4th Edition
Type 1 Enclosure
E175789
629084

For installation instructions see
installation manual or visit
www.LBK10.com



SEALED UNIT PARTS CO., INC.
P.O. Box 21, 2290 Landmark Place
Arlingwood, NJ 07020 USA
www.sugco.com



Scan for more info
at www.LBK10.com

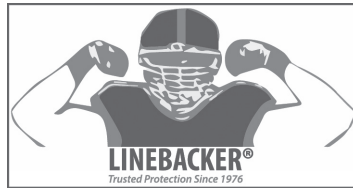

LBK10 LINEBACKER® SURGE PROTECTOR INSTALLATION INSTRUCTIONS

Surge Protectors are designed to protect equipment from most damaging power surges. While protecting the equipment, the surge protector's useful life may end and it will need to be replaced.

Power surges can be caused by a number of environmental conditions, including lightning, which is the obvious source. No surge protector can provide protection from a direct lightning strike. However, the most common cause of damaging surges is actually the local utility company and these surges can be the most damaging due to their duration. Cycling of air conditioners, refrigeration systems, generators, motors and appliances can also produce damaging surges.

The LBK10 Linebacker surge protector is designed to meet the requirements of UL® 1449 4th Edition and is approved by UL® - Look for the UL® mark.



WARNING! Risk of Fire or Electric Shock

- Completely read these instructions before installing the unit.
- Installation and service must be performed by a qualified licensed professional.
- Disconnect power at the circuit breaker(s) before installation or service of this device and the equipment it is intended to protect.
- All wiring must comply with state and local electrical codes, including the National Electrical Code (NEC) and Canadian Electrical Code (CEC).
- This product is intended for indoor and outdoor use.
- This surge protector contains no serviceable parts.
- **Failure to wire a surge protector correctly could result in fire or fatality. SUPCO will assume no responsibility for a failed unit due to improper wiring.**



THE IMPORTANCE OF GROUND

A surge protector works by shunting the voltage surge to ground. A good ground is imperative in order for the product to operate properly and for safety. The National Electrical Code (NEC) maximum resistance at ground is 25 ohms. Have a procedure in place to check the ground system of the installation location both at the time of installation and periodically thereafter.

NOTE: Some older homes, with older electrical wiring, do not have a ground present. A **GOOD GROUND IS IMPERATIVE** for the surge protector to properly protect equipment and for safety reasons. If no ground is present, be sure to establish one and confirm that it meets the NEC code. If satisfactory ground cannot be established, do not install the surge protector.

CAUTION: Ungrounded power systems are inherently unstable and can produce excessively high line-to-ground voltages during certain fault conditions. During these fault conditions any electrical equipment, including a surge protective device, may be subjected to voltages which exceed their designed ratings. This information is being provided to the user so that an informed decision can be made before installing any electrical equipment on an ungrounded power system.

FUNCTIONAL DESCRIPTION

When properly installed, this device features internal protection that will disconnect the intended protected equipment from power when the surge protective circuitry is compromised. Use the “Operational Output” to enable activation of the contactor coil circuit and disable power to the equipment when the protector fails. Use the “Alarm Output” connection to activate an external alarm or indicator. External alarm or indicator components are not supplied with this product.

The LBK10 also incorporates unique circuitry that detects and indicate when there is an over voltage or under voltage condition. Moreover, this device will detect and indicates when there is a loss of neutral or ground to the surge protector. A good ground is imperative for the proper function of the surge protector.

LED INDICATOR GUIDE

LED CONDITION	DESCRIPTION	CAUSE	CORRECTION
On Steady	Equipment is protected	Unit is ok	No correction needed
Off	Equipment is NOT protected	Unit has no power.	Ensure proper power is restored to unit
		Unit has taken a surge	Replace unit
Continuous Flash	Initialization period	Upon power up unit takes 3 min. to initialize and verify proper voltages and neutral/ground present	Wait until unit has initialized
One Flash followed by a pause	Over voltage	One or both phases are above the voltage tolerance.	Correct the over voltage condition
Two Flashes followed by a pause	Under voltage	One or both phases are below the voltage tolerance.	Correct the under voltage condition
Three Flashes followed by a pause	Loss of Neutral / Ground	Check to verify that the unit is connected to a ground source that is 25 ohms or less to ground. Verify that the neutral ground is good coming into the main electrical panel.	Correct the loss of neutral/ground condition to the unit

INSTALLATION TIPS:

1. Never sharply bend the surge arrestor wires during termination.
2. Keep the black and white surge arrestor wires as short as possible, and connect the white wire to the best available ground point. This increases the effectiveness and response time of the unit.
3. Always keep the protector at least 3 linear feet (wire length) from the device that is to be protected. This allows proper response time for the protector to do its job before the transient power surge reaches the protected equipment. The average wire length from a condenser's compressor to the power control board usually exceeds 3 feet.

FIELD WIRING

Black: L1 and L2
White: Neutral/Ground
Brown: Relay Common
Grey: Operational Output
Blue: Alarm Output

Installation in Condensing Unit, Air Handlers and Furnaces (HVAC Applications)

The LBK10 surge protector is intended to be installed directly in the equipment that you wish to be protected.

**Figure 1A:
208/240VAC Application**

208/240 Volt Wiring

Black to L1

Black to L2

White to Neutral/Ground

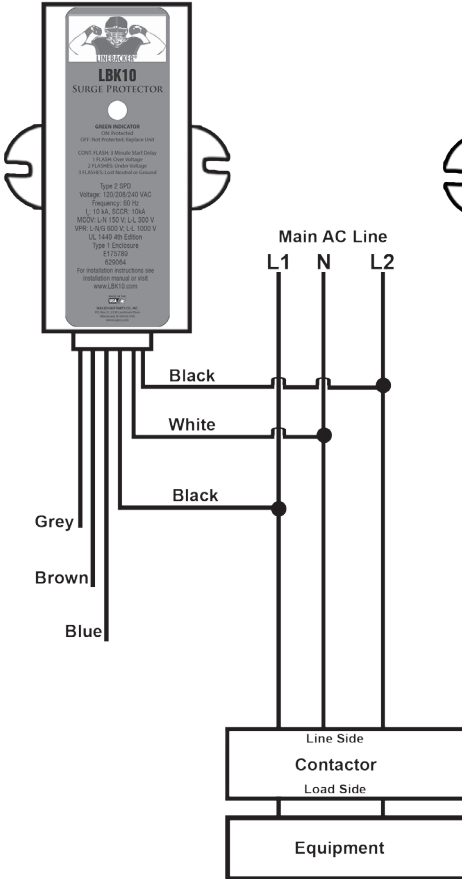

**Figure 1B:
120VAC Application**

120 Volt Wiring

Black to L1

Black to L1

White to Neutral/Ground

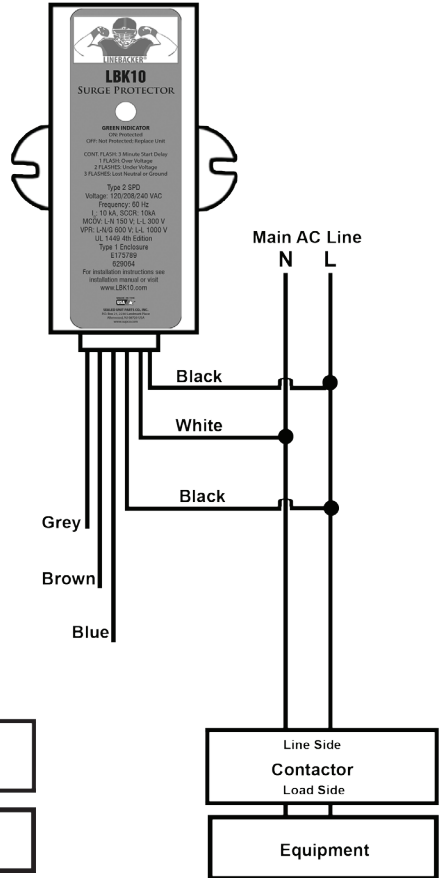

Go to www.LBK10.com
for wiring
diagrams for other
system
configurations

**NOTE: For 120VAC
application, connect
both black wires to line.**

Condensing Unit

For an outdoor condensing unit, install the unit on the inside the cabinet area behind the equipment cover.

- When installing inside the equipment, be sure to use the external tabs on the surge protector case to secure it to the cabinet case.
- Keep the leads as short as possible and make sure there are no 90 degree bends.

To install the LBK10 onto the condensing unit:

1. Disconnect power to the condensing unit at the AC disconnect and circuit breaker(s).
2. Remove the panel covering the main power feed into the condensing unit.
3. Wire the black and white leads as per the voltage designations in Figure 1A or 1B for 120V or 240V equipment. Be sure to connect to the LINE SIDE of the contactor. Utilize the available lugs inside the condenser.
4. Connect the wires for the outputs as per the instructions in Figure 2A or 2B.

NOTE: Flexible conduit may be used as an option inside the enclosure

5. Re-attach the panel covering the main power feed.
6. Re-connect power at the AC disconnect and circuit breaker(s).
7. After flashing for the 3 minute initialization period, the LED on the surge protective device should be steadily illuminated green at this time.
8. If the LBK10 flashes with a pause, consult the “LED Indicator Guide” for cause and appropriate action.

Air Handler

For an indoor air handler, install the unit through the side of the air handler into the control box where the main power feed enters the air handler. Keep the leads as short as possible and make sure there are no 90 degree bends.

To install the unit onto the air handler:

1. Disconnect power to the air handler either at the junction box feeding the air handler or the circuit breaker feeding the air handler.
2. Remove the panel to access the box where the main power feed enters the air handler.
3. Drill a hole for a 1/2" nipple into the side of the air handler so that the leads can feed into the box where the main power feed is or use a knockout in the panel inside the air handler.
4. Wire the black leads to the hot lugs in the control bus and wire the white lead onto the ground lug.
5. Connect the wires for the outputs as per the instructions in Figure 2A or 2B.
6. Re-attach the panel on the air handler.
7. Re-connect power to the air handler.
8. After flashing for the 3 minute initialization period, the LED on the surge protective device should be steadily illuminated green at this time.
9. If the LBK10 flashes with a pause, consult the "LED Indicator Guide" for cause and appropriate action.

Furnace

For a furnace, install the unit into the control box where the main power feed enters the furnace. Keep the leads as short as possible and make sure there are no 90 degree bends.

To install the unit onto a furnace:

1. Disconnect power to the furnace at the AC disconnect, junction box or circuit breaker feeding the furnace.
2. Remove the panel covering the control box where the main power feed enters the furnace.
3. Wire the black leads to the hot lugs on the furnace and the white lead to the ground lug.
4. Connect the wires for the outputs as per the instructions in Figure 2A or 2B.
5. Re-attach the panel on the furnace.
6. Re-connect power to the furnace.
7. After flashing for the 3 minute initialization period, the LED on the surge protective device should be steadily illuminated green at this time.
8. If the LBK10 flashes with a pause, consult the “LED Indicator Guide” for cause and appropriate action.

Connecting Outputs (Fig.2)

1. Connect the wires for the outputs in order to remove power from condensing unit contactor (Operational Output) and/or activate an external alarm if the surge protector has been compromised (Alarm Output).
2. The brown wire is common.
3. Connect the gray wire as the Operational Output and the blue wire as the Alarm Output.

Figure 2A:
 In this configuration the Alarm Output would only energize when the common has signal from the thermostat.

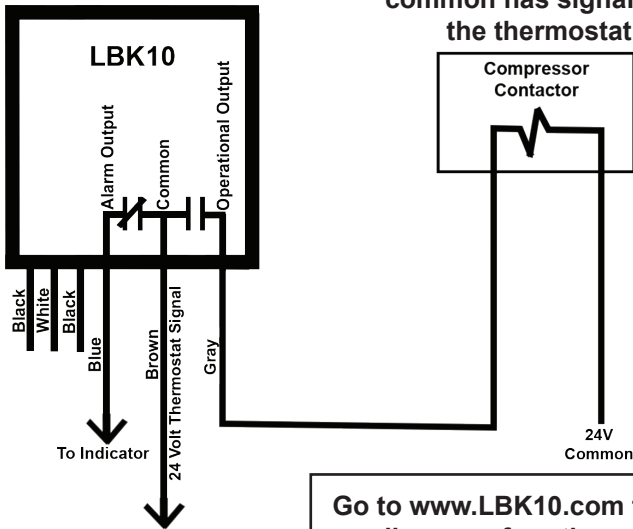

Go to www.LBK10.com for wiring diagrams for other system configurations

Figure 2B:
 In this configuration the Alarm Output will operate even if the thermostat is not trying to run the compressor. Requires another external relay.

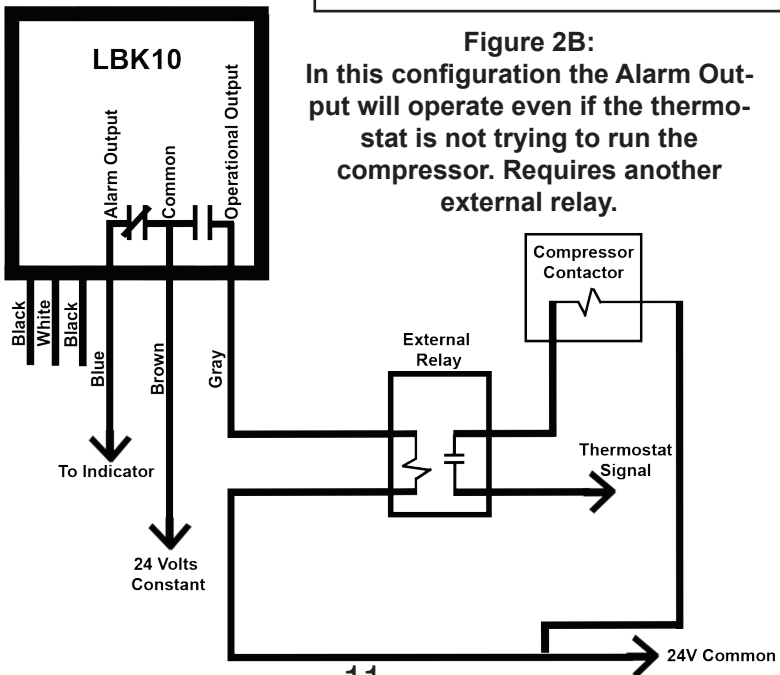

SPECIFICATIONS

TYPE 2 SPD

Voltage: 120/208/240VAC; Single Phase

Frequency: 60 Hz

Normal Discharge Current (In): 10kA

Short Circuit Current Rating (SCCR): 10kA

Max. Continuous Operating Voltage (MCOV): L-N 150V

Voltage Protection Rating (VPR): L-N/G 600V; L-L 1000V

Operating Temperature: -40°F to 158°F (-40°C to 70°C)

Type 1 Enclosure

Relay Specifications

NO/NC Relay

Contact Rating: 2A, 24V, AC/DC

FOR FURTHER INFORMATION CONTACT
TECHNICAL SUPPORT AT 1-800-333-9125
OR GO TO WWW.LBK10.COM



SEALED UNIT PARTS CO., INC
P.O. Box 21, 2230 Landmark Place
Allenwood, NJ 08720 USA

www.supco.com

Rev 03152016