

### DESCRIPTION

Straits Lighting LED Wall Pack fixtures offer enhanced performance in a design that easily replaces existing fixtures. These highly efficient fixtures use SMD LED chips to provide enhanced illumination for increased security in parking areas and structures. All Straits Lighting LED Wall Packs are **UL and cUL** certified.



### SPECIFICATION FEATURES

#### OPTICS

- ◆ Prismatic Lens
- ◆ Beam Angle: 120°

#### MOUNTING

- ◆ Wall-mounted
- ◆ Easily replaces existing fixtures

#### FINISH

- ◆ Die-cast aluminum housing
- ◆ Bonded coating for added durability

#### WARRANTY

- ◆ **FIVE** year warranty

#### LED MODULES

- ◆ Non-dimmable
- ◆ High brightness LUMILEDS LEDs
- ◆ Mercury Free
- ◆ Color temperature of 5000 Kelvin (4000 Kelvin available for special order)

#### CONSTRUCTION

- ◆ Integrated thermal management system
- ◆ Waterproof internal aluminum LED board
- ◆ Fire resistant enclosure

Product #	<b>SL923WPG2/ SL923WPG</b>
Project	
Comments	
Prepared By	
Date	

#### ENERGY DATA

- ◆ Electronic LED Driver
- ◆ Power Factor > 0.9
- ◆ Total Harmonic Distribution < 20%
- ◆ 100-277V 50/60Hz
- ◆ -4°F (-20°C) Min. Temperature
- ◆ 104°F (40°C) Max. Temperature

#### CERTIFICATION DATA

- ◆ UL/cUL Certified
- ◆ DLC Listed (50W, 60W, 80W models only)
- ◆ LM79/IES tested
- ◆ IP65 Rated



# PRODUCT DETAILS

LED - WALL PACK

Product Code	Wattage (W)	Input (VAC)	CCT (K)	Beam Angle	Initial Lumens (lm)	Rated Efficacy	Rated Life (hrs)	CRI	Power Factor	Dimmable	Certificate
SL923WPG2	50	100/277	5000	120	5,965	123.97	50,000	>70	> .9	No	UL/cUL
SL923WPG2	60	100/277	5000	120	7,231	119.48	50,000	>70	> .9	No	UL/cUL
SL923WPG2	80	100/277	5000	120	9,953	127.57	50,000	>70	> .9	No	UL/cUL
SL923WPG	120	100/277	5000	120	9,940	82	50,000	>70	> .9	No	UL/cUL

1. CCT range complies to ANSI C78.377-2008
2. Rated average life based on engineering testing and probability analysis
3. Lifetime test consistent with IESNA LM80 lumen maintenance procedure

# PRODUCT DIMENSIONS

Product	Wattage (W)	Length (Inches)	Width (Inches)	Height (Inches)
SL923WPG2	50/60/80	15.06	9.29	7.46
SL923WPG	120	18.29	9.09	9.4

# Mounting

Direct wall-mount installation

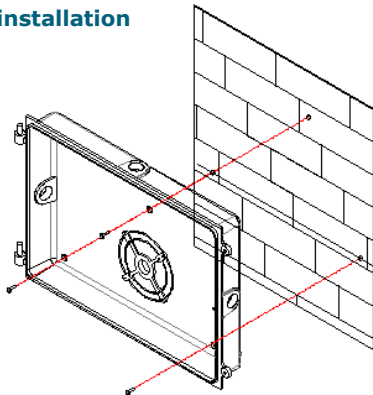

Junction box installation

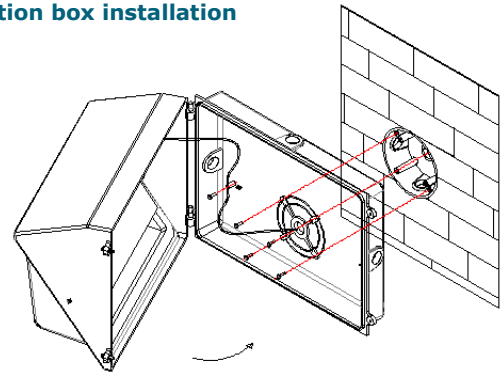

# ORDERING INFORMATION

SAMPLE NUMBER: SL923WPG2-120W-100/277V-5000-N

<b>SL923WPG2</b>		<b>100/277V</b>	<b>5000</b>	<b>N</b>
<b>Category</b> SL923WPG2 = Wall Pack SL923WPG = Wall Pack (Gen 1)	<b>Wattage</b> 50W = 50W 60W = 60W 80W = 80W 120W = 120W	<b>Voltage</b> 100/277V = 100/277V	<b>CCT</b> 5000 = 5000K	<b>Dimming</b> N = Non-Dimming

# CONTACT US

**Phone:** (855) TSLC - LED  
(855) 875 - 2533  
**Fax:** (248) 671 - 0624

**Address:**  
12501 E. Grand River Ave.  
Suite 200  
Brighton, MI 48116



The Straits Lighting Company is constantly developing and improving its products. For this reason, all product descriptions in this brochure are intended as a general guide, and we may change specifications from time to time in the interest of product development, without prior notification or public announcement. All descriptions in this publication present only general particulars of the goods to which they refer and shall not form part of any contract. Data in this guide has been obtained in controlled experimental conditions. However, The Straits Lighting Company cannot accept any liability arising from the reliance on such data to the extent permitted.