

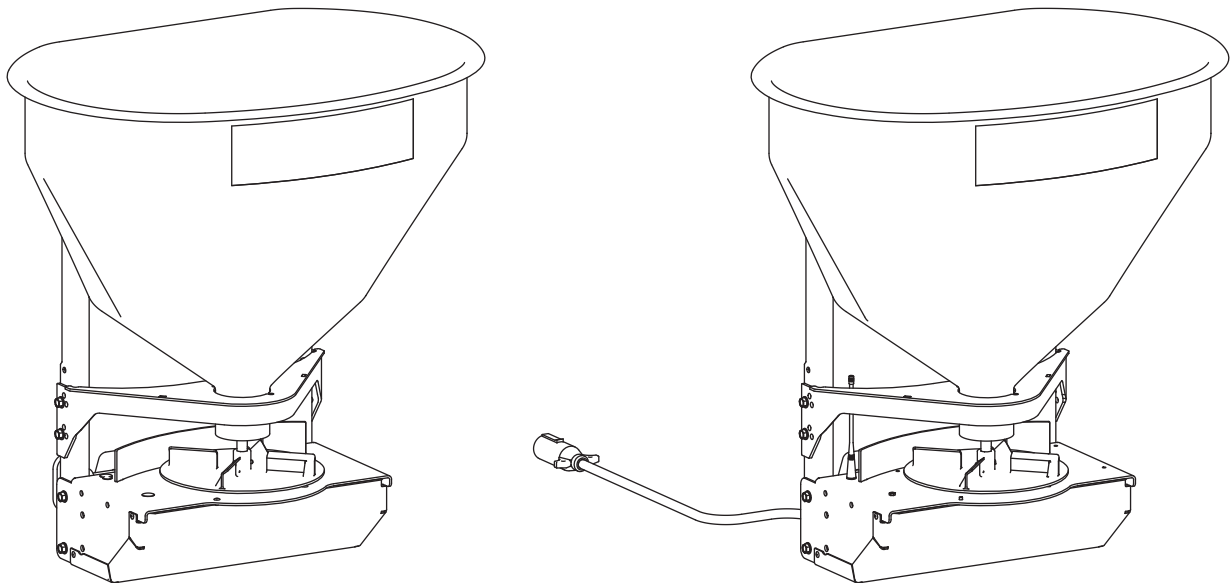

SP-225-1 & SR-210 Tailgate Spreader

Owner's Manual and Installation Instructions
Original Instructions



⚠ CAUTION

Read this manual before installing or
operating the spreader.

This manual is for SnowEx® SR-210 tailgate spreaders with serial numbers beginning with 151013 and higher,
and SP-225-1 tailgate spreaders with serial numbers beginning with 170109 and higher.

This document supersedes all editions with an earlier date.

TABLE OF CONTENTS

INTRODUCTION	4	REMOVING THE SPREADER	18
Owner's Information Form	4	MODEL SR-210 WIRELESS CONTROL PAIRING AND PROGRAMMING	19
SAFETY	5	MAINTENANCE	21
LOADING	10	Lubrication	21
Certification.....	10	After Each Use.....	21
Approximate Material Weights	10	At the End of Each Season or after Extended Storage.....	21
MOUNTING THE SPREADER	11	Storage	21
Assembly Instructions.....	11	TROUBLESHOOTING	22
Receiver Mount Spreader.....	12	Tailgate Spreader.....	22
ELECTRICAL DIAGRAM		Wireless Key Fob Control	23
Model SP-225-1	13	WIRELESS COMPLIANCE	24
Model SR-210	14		
OPERATING THE SPREADER	15		
Driving and Spreading on Snow and Ice	15		
Model SP-225-1	16		
Model SR-210	17		
Ensuring that the Spreader has Power.....	17		
Starting and Stopping Motor.....	17		
Spreading Tips.....	17		

INTRODUCTION

This manual has been prepared to acquaint you with the safety information, operation, and maintenance of your new tailgate spreader. Please read this manual carefully and follow all recommendations. This will help ensure profitable and trouble-free operation of your tailgate spreader. Keep this manual accessible. It is a handy reference in case minor service is required.

When service is necessary, bring your spreader to your distributor. They know your spreader best and are interested in your complete satisfaction.

NOTE: This spreader is designed to spread snow and ice control materials only. Do not use it for purposes other than those specified in this manual.

Warranty Registration

Follow the directions on the SnowEx® Warranty Registration and Customer Survey form included in the spreader literature kit.

The registration form is also available online at www.snowexproducts.com. Under "Support" select "Warranty Registration."

OWNER'S INFORMATION

Owner's Name: _____

Date Purchased: _____

Distributor Name: _____ Phone: _____

Distributor Address: _____

Vehicle Model: _____ Year: _____

Spreader Model: _____ Serial #: _____

Spreader Weight: _____ lb/kg

SAFETY

SAFETY DEFINITIONS

⚠ WARNING

Indicates a potentially hazardous situation that, if not avoided, could result in death or serious personal injury.

⚠ CAUTION

Indicates a potentially hazardous situation that, if not avoided, may result in minor or moderate injury. It may also be used to alert against unsafe practices.

NOTE: Indicates a situation or action that can lead to damage to your spreader and vehicle or other property. Other useful information can also be described.

WARNING/CAUTION LABELS

Please become familiar with the warning and caution labels on the spreader.

NOTE: If labels are missing or cannot be read, see your sales outlet.

⚠ WARNING

- Read owners manual before operating equipment.
- Never remove spreader with material in hopper.

D6194

⚠ WARNING

- Keep hands, feet & loose clothing away from moving parts.
- Disconnect power before servicing equipment.

D6192

⚠ WARNING

**Maximum Weight Capacity
240 lbs.**

D6402

⚠ WARNING

Vehicles <10,000 lb GVWR

Obstructing the visibility from the vehicle's rear camera could result in serious injury or damage. An auxiliary camera system shall be installed if the vehicle's rear camera is removed or blocked.

11100.00

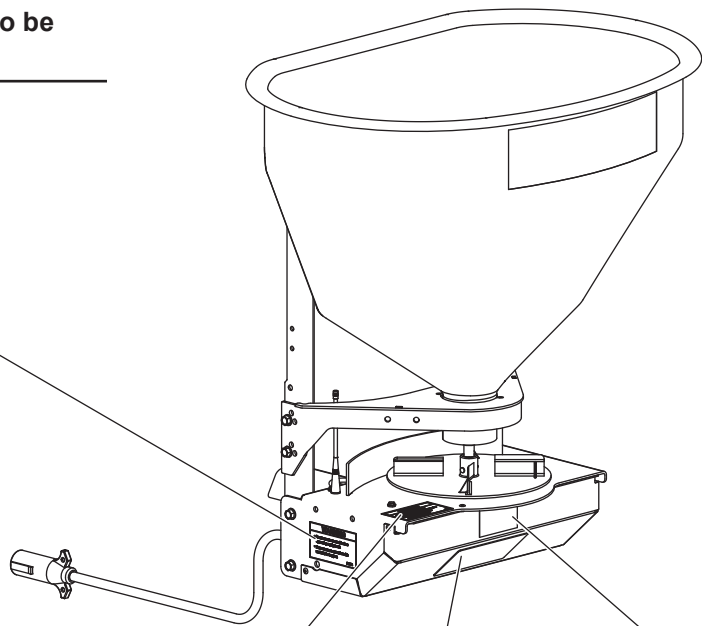

SAFETY

SERIAL NUMBER LABEL

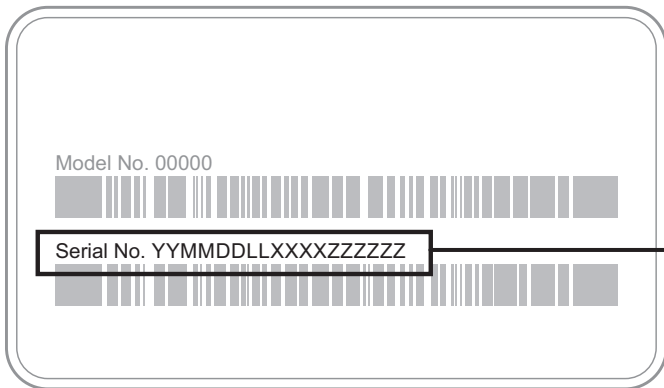
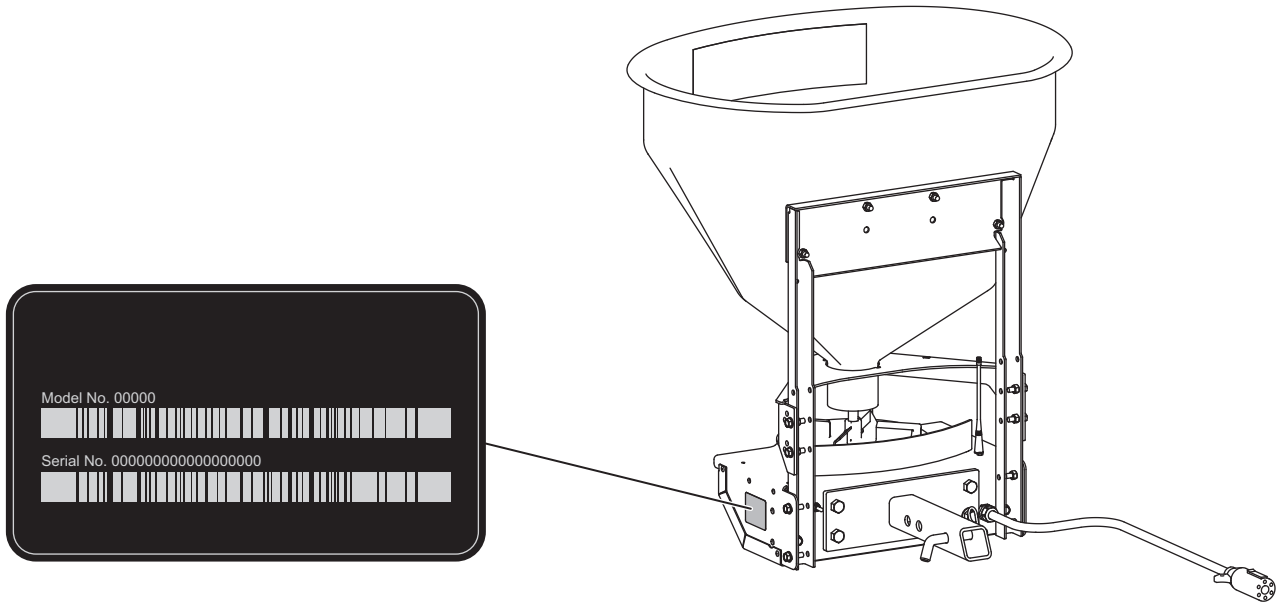

Code	Definition
YY	2-Digit Year
MM	2-Digit Month
DD	2-Digit Day
LL	2-Digit Location Code
XXXX	4-Digit Sequential Number
ZZZZZ	Assembly Part Number

SAFETY

SAFETY PRECAUTIONS

Improper installation and operation could cause personal injury and/or equipment and property damage. Read and understand labels and the Owner's Manual before installing, operating, or making adjustments.

⚠ WARNING

- Driver to keep bystanders minimum of 25 feet away from operating spreader.
- Before working with the spreader, secure all loose-fitting clothing and unrestrained hair.
- Before operating the spreader, verify that all safety guards are in place.
- Before servicing the spreader, wait for auger and spinner to stop.
- Do not climb into or ride on spreader.

⚠ WARNING



Overloading could result in an accident or damage. Do not exceed GVWR or GAWR ratings as found on the driver-side door cornerpost of the vehicle. See Loading section to determine maximum volumes of spreading material.

⚠ WARNING

Vehicles <10,000 lb GVWR: Obstructing the visibility from the vehicle's rear camera could result in serious injury or damage. An auxiliary camera system shall be installed if the vehicle's rear camera is removed or blocked.

⚠ CAUTION

If rear directional, CHMSL light, or brake stoplights are obstructed by the spreader, the lights shall be relocated, or auxiliary directional or brake stoplights shall be installed.

⚠ CAUTION

During the hopper spreader installation we recommend the addition of an OSHA compliant Backup Alarm. This alarm is required for OSHA governed employers.

⚠ CAUTION

- Do not operate a spreader in need of maintenance.
- Before operating the spreader, reassemble any parts or hardware removed for cleaning or adjusting.
- Before operating the spreader, remove materials such as cleaning rags, brushes, and hand tools from the spreader.
- While operating the spreader, use auxiliary warning lights, except when prohibited by law.
- Tighten all fasteners according to the Torque Chart. Refer to Torque Chart for the recommended torque values.

⚠ CAUTION

Disconnect electric and/or hydraulic power and tag out if required before servicing or performing maintenance.

⚠ CAUTION



DO NOT leave unused material in hopper. Material can freeze or solidify, causing unit to not work properly. Empty and clean after each use.

NOTE: Lubricate grease fittings after each use. Use a good quality multipurpose grease.

PERSONAL SAFETY

- Remove ignition key and put the vehicle in PARK or in gear to prevent others from starting the vehicle during installation or service.
- Wear only snug-fitting clothing while working on your vehicle or spreader.
- Do not wear jewelry or a necktie, and secure long hair.
- Wear safety goggles to protect your eyes from battery acid, gasoline, dirt, and dust.
- Avoid touching hot surfaces such as the engine, radiator, hoses, and exhaust pipes.
- Always have a fire extinguisher rated BC handy, for flammable liquids and electrical fires.

SAFETY

FIRE AND EXPLOSION

⚠ WARNING

Gasoline is highly flammable and gasoline vapor is explosive. Never smoke while working on vehicle. Keep all open flames away from gasoline tank and lines. Wipe up any spilled gasoline immediately.

Be careful when using gasoline. Do not use gasoline to clean parts. Store only in approved containers away from sources of heat or flame.

CELL PHONES

A driver's first responsibility is the safe operation of the vehicle. The most important thing you can do to prevent a crash is to avoid distractions and pay attention to the road. Wait until it is safe to operate Mobile Communication Equipment such as cell phones, text messaging devices, pagers, or two-way radios.

VENTILATION

⚠ WARNING

Vehicle exhaust contains lethal fumes. Breathing these fumes, even in low concentrations, can cause death. Never operate a vehicle in an enclosed area without venting exhaust to the outside.

BATTERY SAFETY

⚠ CAUTION

Batteries normally produce explosive gases which can cause personal injury. Therefore, do not allow flames, sparks, or lit tobacco to come near the battery. When charging or working near a battery, always cover your face and protect your eyes, and also provide ventilation.

- Batteries contain sulfuric acid which burns skin, eyes, and clothing.
- Disconnect the battery before removing or replacing any electrical components.

SAFETY

NOISE

Airborne noise emission during use is below 70 dB(A) for the spreader operator.









VIBRATION

Operating snowplow vibration does not exceed 2.5 m/s² to the hand-arm or 0.5 m/s² to the whole body.

TORQUE CHART

⚠ CAUTION

Read instructions before assembling. Fasteners should be finger tight until instructed to tighten according to torque chart. Use standard methods and practices when attaching spreader including proper personal protective safety equipment.

Recommended Fastener Torque Chart					
Inch Fasteners Grade 5 and Grade 8					
Size	Torque (ft-lb)		Size	Torque (ft-lb)	
	 Grade 5	 Grade 8		 Grade 5	 Grade 8
1/4-20	8.4	11.9	9/16-12	109	154
1/4-28	9.7	13.7	9/16-18	121	171
5/16-18	17.4	24.6	5/8-11	150	212
5/16-24	19.2	27.3	5/8-18	170	240
3/8-16	30.8	43.6	3/4-10	269	376
3/8-24	35.0	49.4	3/4-16	297	420
7/16-14	49.4	69.8	7/8-9	429	606
7/16-20	55.2	77.9	7/8-14	474	669
1/2-13	75.3	106.4	1-8	644	909
1/2-20	85.0	120.0	1-12	704	995
Metric Fasteners Class 8.8 and 10.9					
Size	Torque (ft-lb)		Size	Torque (ft-lb)	
	 Class 8.8	 Class 10.9		 Class 8.8	 Class 10.9
M6 x 1.00	7.7	11.1	M20 x 2.50	325	450
M8 x 1.25	19.5	26.9	M22 x 2.50	428	613
M10 x 1.50	38.5	53.3	M24 x 3.00	562	778
M12 x 1.75	67	93	M27 x 3.00	796	1139
M14 x 2.00	107	148	M30 x 3.50	1117	1545
M16 x 2.00	167	231	M33 x 3.50	1468	2101
M18 x 2.50	222	318	M36 x 4.00	1952	2701

These torque values apply to fasteners except those noted in the instructions.

LOADING

This manual covers vehicles which have been recommended for carrying the spreader. Please see your local dealer for proper vehicle applications.

CERTIFICATION

WARNING

New untitled vehicle installation of a spreader requires National Highway Traffic Safety Administration altered vehicle certification labeling. Installer to verify that struck load of snow or ice control material does not exceed GVWR or GAWR rating label and complies with FMVSS.

APPROXIMATE MATERIAL WEIGHTS

WARNING

Overloading could result in an accident or damage. Do not exceed GVWR or GAWR as found on the driver-side cornerpost of vehicle.

WARNING

Do not overload vehicle. Use chart below to calculate weight of material. Weights of material are an average for dry materials.

CAUTION

Never use wet materials or materials with foreign debris with any of these spreaders. These units are designed to handle dry, clean, free flowing material.

CAUTION



Read and adhere to manufacturer's ice-control material package labeling including Material Safety Data Sheet requirements.

Material	Density (lb/ft ³)
Rock Salt (Dry)	80–90

Weight of spreader and mount must be added to struck material weight to determine total spreader weight. Do not exceed maximum material capacity as shown on the safety label (see Safety section).

Use only bagged rock salt with the spreader. Other forms of spreading material are not compatible with the tailgate spreader.

NOTE: If spreader and ice control material loading is in doubt, weigh vehicle for compliance with vehicle ratings.

MOUNTING THE SPREADER

ASSEMBLY INSTRUCTIONS

The spreader shall be installed according to instructions supplied. Your local outlet is trained to provide this service and service your spreader with factory original parts.

1. Place the drive assembly on a flat, level surface. Attach the receiver mount to the drive assembly as shown below using four $1/2" \times 1-1/2"$ cap screws. Tighten the fasteners according to the torque chart.

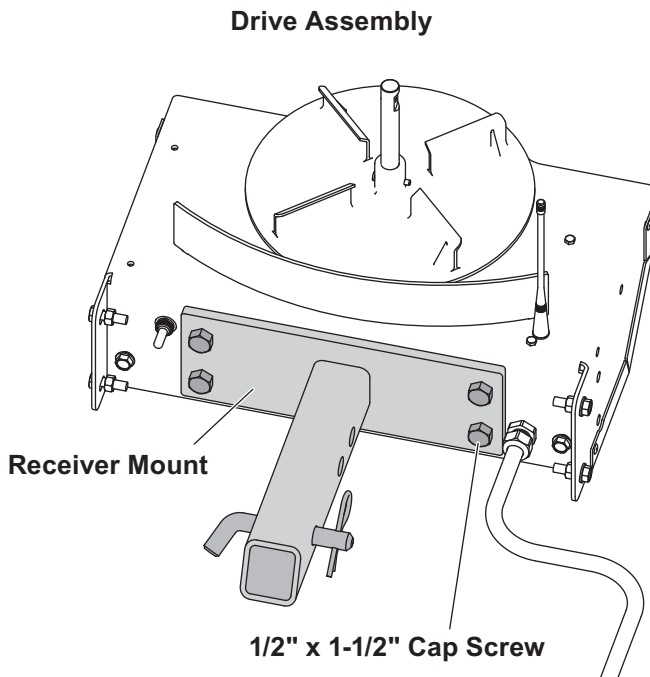

2. Mount the support frame to the drive assembly using the six supplied $5/16" \times 1"$ cap screws and the four supplied $5/16"$ locknuts. Tighten the fasteners according to the torque chart.

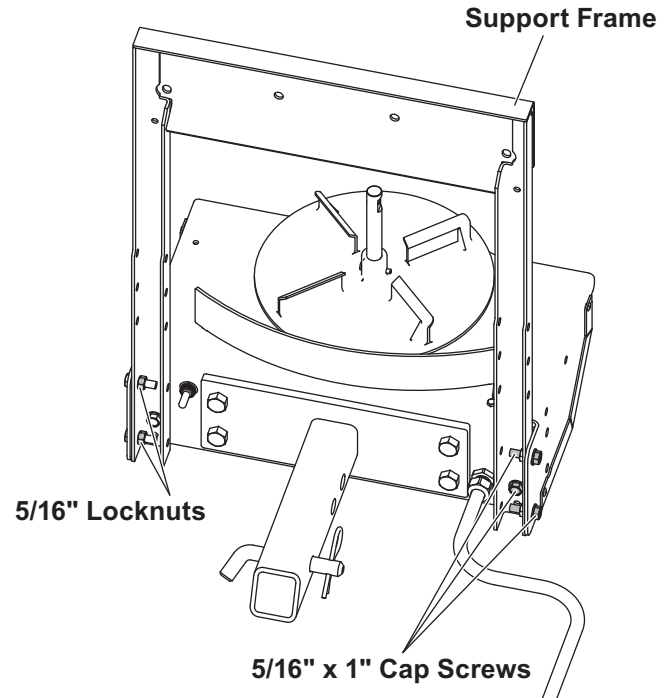

3. Mount the throat support to the support frame at the two lower holes by using the four supplied $5/16" \times 1"$ cap screws and $5/16"$ locknuts. Tighten the fasteners according to the torque chart.

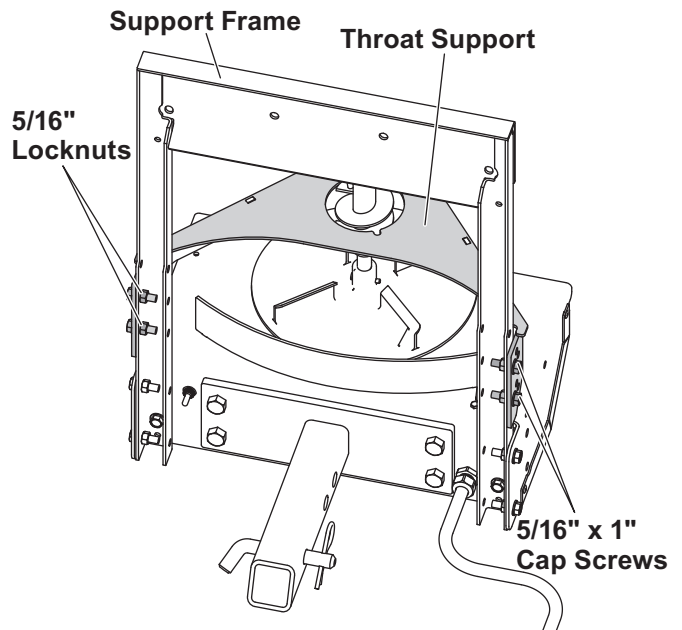

MOUNTING THE SPREADER

⚠ CAUTION

Before drilling holes, check to be sure that no vehicle wiring or other components could be damaged.

4. Drill four holes in the hopper using the support frame holes as a template. Place the backing plate inside the hopper.
5. Fasten the hopper to the support frame by running the four supplied 5/16" x 1" cap screws through the backing plate, hopper, and support frame from inside the hopper. Attach using the four supplied 5/16" locknuts. Tighten the fasteners according to the torque chart.

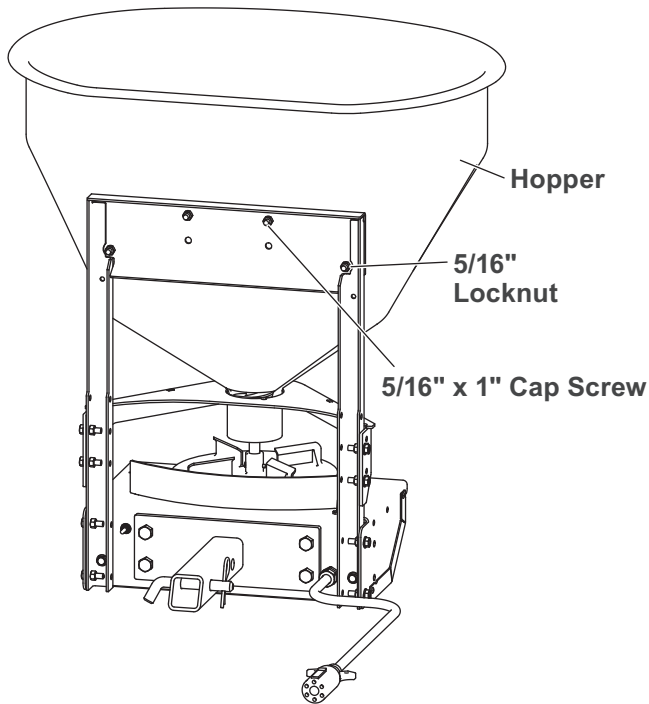

RECEIVER MOUNT SPREADER

⚠ CAUTION

During removal or mounting, securely grip spreader to avoid dropping.

The spreader shall be installed according to instructions supplied. Your local outlet is trained to provide this service and service your spreader with factory original parts.

Insert the assembled unit into the receiver hitch and secure with the supplied hitch pin and hairpin cotter.

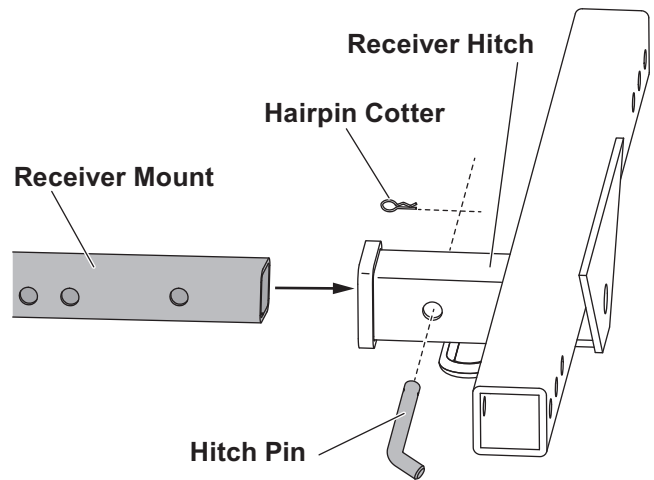

ELECTRICAL DIAGRAM – MODEL SP-225-1

WIRING DIAGRAM: MODEL SP-225-1

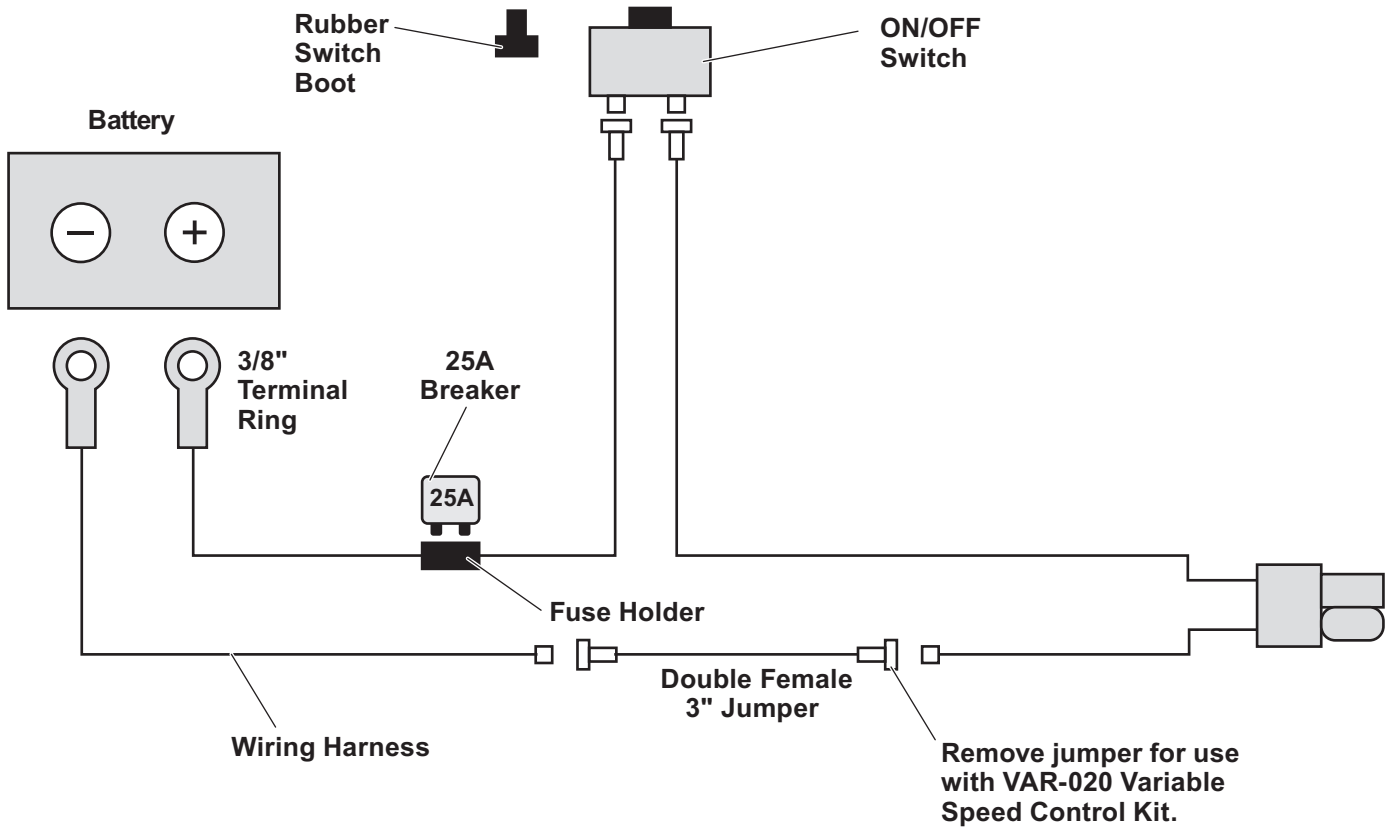

IMPORTANT: In the off-season, remove the control and put in a cool, dry place. The interior summer temperatures could damage the circuit board and void the warranty.

Wiring Instructions for Model SP-225-1

1. Install switch at desired location.
2. Run the spreader/vehicle harness from the rear of the vehicle to the switch area. Attach the female spade red wire to the switch. Leave the black wire for Step 5.
3. Route the power harness from the battery to the switch/control.
4. Attach the red lead to the POSITIVE (+) side of the battery and the black lead to the NEGATIVE (-) side of the battery.
5. Attach the female spade red wire on the switch terminal. Using 3" double female black wire jumper, attach the black wire from the power harness to the black wire of the vehicle harness.
6. Install the rubber weatherproof boot on the switch before finishing the installation.
7. Apply dielectric grease on the terminals of SAE plug at rear of vehicle.

ELECTRICAL DIAGRAM – SR-210

MODEL SR-210:

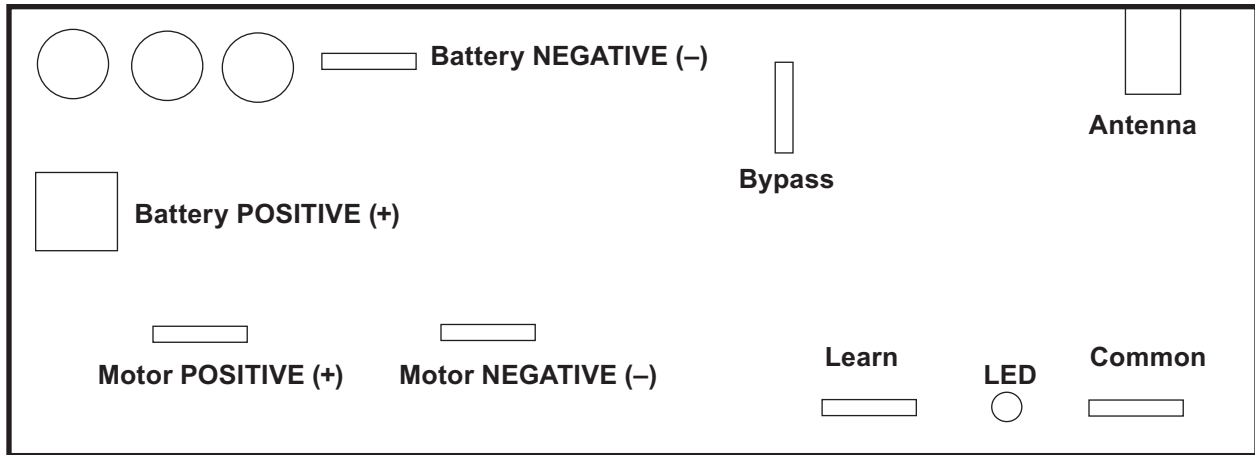

Wireless Receiver Module Connections

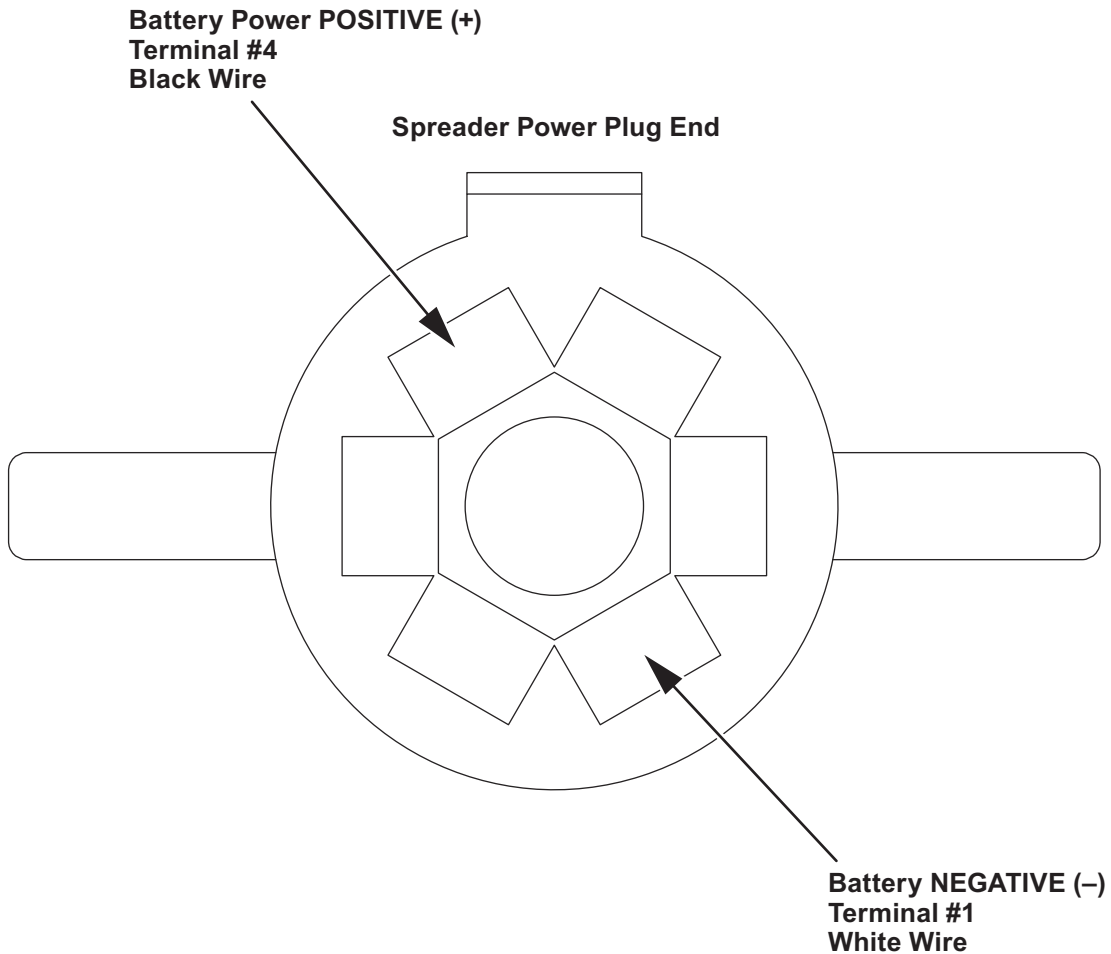

OPERATING THE SPREADER

DRIVING AND SPREADING ON SNOW AND ICE

CAUTION

Drinking and then driving or spreading is very dangerous. Your reflexes, perceptions, attentiveness, and judgment can be affected by even a small amount of alcohol. You can have a serious or even fatal collision if you drive after drinking. Please do not drink then drive or spread ice-control materials.

Follow your vehicle owner's manual instructions for driving in snow and ice conditions. Remember, when you drive on snow or ice, your wheels will not get good traction. You cannot accelerate as quickly, turning is more difficult, and you will need longer braking distance. Wet and hard packed snow or ice offer the worst tire traction. It is very easy to lose control. You will have difficulty accelerating. If you do get moving, you may have poor steering and difficult braking, which can cause you to slide out of control.

Here are some tips for driving in these conditions:

- Drive defensively.
- Do not drink, then drive or spread ice-control materials.
- Spread or drive only when you have good visibility for operating a vehicle.
- If you cannot see well due to snow or icy conditions, you will need to slow down and keep more space between you and other vehicles.
- Slow down, especially on higher-speed roads. Your headlamps can light up only so much road ahead.
- If you are tired, pull off in a safe place and rest.
- The spreader's size and location reduce driver visibility to the rear of the vehicle. We recommend an OSHA compliant backup alarm for all governed employers.
- Keep your windshield and all glass on your vehicle clean to see around you.
- Dress properly for the weather. Wear layers of clothing; as you get warm, you can take off layers.

OPERATING THE SPREADER – MODEL SP-225-1

MODEL SP-225-1

⚠ WARNING

Never operate equipment when under the influence of alcohol, drugs, or medications that might alter your judgment and/or reaction time.

⚠ WARNING

Never exceed 45 mph (72 km/h) when loaded spreader is attached to vehicle. Braking distances may be increased and handling characteristics may be impaired at speeds above 45 mph (72 km/h).

⚠ WARNING

Never allow children to operate or climb on equipment.

⚠ WARNING

Before starting the spreader, the driver shall verify that all bystanders are a minimum of 25 feet away from operating spreader.

The Model SP-225-1 tailgate spreader comes standard with an ON/OFF switch.

To start the spreader: Turn the power ON. Material will begin to flow through the feed auger.

To stop the spreader: Switch the power OFF. Material will cease to spread.

NOTE: The truck ignition must be ON to start the spreader.

NOTE: If truck ignition is turned OFF while spreader is running, the motor will stop.

NOTE: The spinner motor is not designed for continuous duty. Allow the motor to cool between long cycle times.

OPERATING THE SPREADER – MODEL SR-210

MODEL SR-210

⚠ WARNING

Never operate equipment when under the influence of alcohol, drugs, or medications that might alter your judgment and/or reaction time.

⚠ WARNING

Never exceed 45 mph (72 km/h) when loaded spreader is attached to vehicle. Braking distances may be increased and handling characteristics may be impaired at speeds above 45 mph (72 km/h).

⚠ WARNING

Never allow children to operate or climb on equipment.

⚠ WARNING

Before starting the spreader, the driver shall verify that all bystanders are a minimum of 25 feet away from operating spreader.

ENSURING THAT THE SPREADER HAS POWER

The spreader is only compatible with 7-way RV-style trailer plugs. If your vehicle is not equipped with a 7-way trailer plug, contact Customer Support to purchase the necessary electrical harness (PN 75924).

Fuses are supplied with the spreader. One may need to be installed in the truck fuse panel for the 7-way plug to receive power.

1. Begin by unplugging the spreader from the 7-way plug.
2. Push the toggle switch DOWN into the "MANUAL OVERRIDE" position.

⚠ WARNING

The spinner will start immediately upon connecting power while in manual override mode. Keep hands and tools clear of spinner assembly.

3. Plug the spreader into the 7-way plug. The spreader will start at 100% speed.

4. Unplug the spreader, push the toggle switch into the center position, and then replug the spreader. The spreader must be unplugged after running an override. The wireless key fob control will remain locked out until power is removed from the spreader unit.
5. If power is not present, consult the trailering section in the vehicle owner's manual for more information.

STARTING AND STOPPING MOTOR

To start the spreader, press either the "50%" or "100%" speed button on the control.

Press the "OFF" button in the middle of the control to stop the spreader.

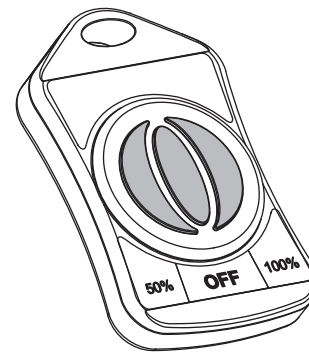

NOTE: The truck ignition must be ON to start the spreader.

NOTE: If truck ignition is turned OFF while spreader is running, the motor will stop.

NOTE: The spinner motor is not designed for continuous duty. Allow the motor to cool between long cycle times.

SPREADING TIPS

- Spread ice melters with the storm to prevent unmanageable levels of ice.
- Never exceed 10 mph (16 km/h) when spreading.
- For a heavier pass, drive slower.
- Never operate spreader near pedestrians.
- Calculate spread pattern when near vegetation.

REMOVING THE SPREADER

⚠ CAUTION

Empty the hopper before removing the spreader.

⚠ CAUTION

During removal or mounting, securely grip spreader to avoid dropping.

1. Unplug the spreader harness from the vehicle harness.
2. Remove the hitch pin from the receiver hitch.
3. Remove the spreader from the vehicle and stand it in an upright position. This may require additional support.

WIRELESS CONTROL PROGRAMMING AND PAIRING

WHEN TO PROGRAM AND PAIR THE WIRELESS KEY FOB CONTROL

The wireless key fob control included with the spreader should come paired and ready for use.

If the spreader does not respond to the wireless key fob control, or after replacing the battery (CR2032 battery or equivalent), you will need to program the wireless key fob control and pair it to the spreader's wireless control module.

ENSURING THAT THE SPREADER HAS POWER

The spreader is only compatible with 7-way RV-style trailer plugs. If your vehicle is not equipped with a 7-way trailer plug, contact Customer Support to purchase the necessary electrical harness (PN 75924).

1. The spreader must be receiving power from the vehicle to pair and program the wireless key fob control. Begin by unplugging the spreader from the 7-way plug.
2. Push the toggle switch **DOWN** into the "MANUAL OVERRIDE" position.

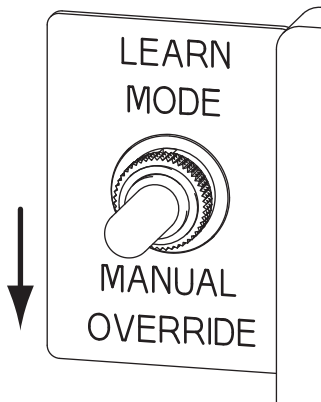

⚠ WARNING

The spinner will start immediately upon connecting power while in manual override mode. Keep hands and tools clear of spinner assembly.

3. Plug the spreader into the 7-way plug. Be sure to check that the plug polarity is correct as shown below. The spreader will start at 100% speed.

Spreader Power Plug End View

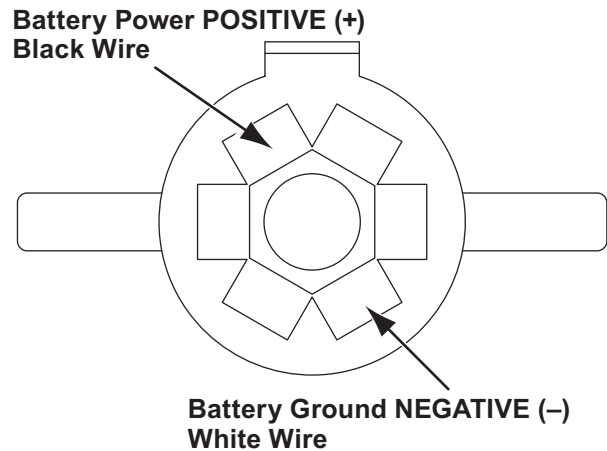

4. Unplug the spreader, push the toggle switch into the center position and then reconnect power to the spreader.

The spreader must be unplugged after running an override. The wireless key fob control will remain locked out until power is removed from the spreader unit.

5. If power is not present, consult the trailering section in the vehicle owner's manual for more information.

WIRELESS CONTROL PROGRAMMING AND PAIRING

PROGRAMMING AND PAIRING THE WIRELESS KEY FOB CONTROL

Resetting the Wireless Control Module

Push and hold the toggle switch UP into the "LEARN MODE" position for 15 seconds and then release. This erases all previously paired wireless key fob controls from memory.

A wireless key fob control must be paired before the spreader will operate.

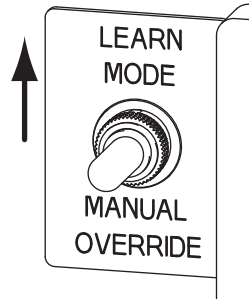

Programming the Wireless Key Fob Control

1. Gently press the end of a pointed object (e.g., ballpoint pen) into the small hole on the underside of the wireless key fob control. A blue light on the underside of the key fob will flash for 10–15 seconds, indicating that the wireless key fob control will accept programming.



2. While the blue light is flashing, press the wireless key fob control buttons in the following sequence:

50%, OFF, 100%, 50%, OFF, 100%.

The sequence must be completed before the blue light stops flashing.

Pairing the Wireless Key Fob Control to the Wireless Control Module

1. Check that the wireless control module is receiving a signal by confirming that a red light is visible through the bottommost hole in the toggle switch-side of the transmission mount.

⚠ WARNING

The spinner will start immediately upon successful pairing. Keep hands and tools clear of spinner assembly.

2. Press and hold the "50%" button on the wireless key fob control. While holding the button, push the toggle switch UP into the "LEARN MODE" position twice and release the toggle switch. Continue holding the button for 30 seconds and the spreader will start at 50% speed.

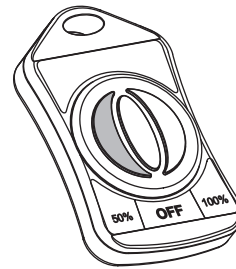

If the spreader does not start, release the "50%" button, wait 20 seconds, and then repeat Step 2.

3. Press the "100%" button to make sure that the spreader runs at 100% speed.

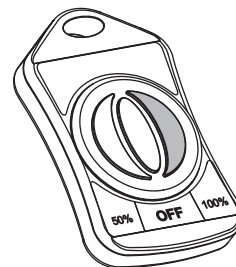

If any of the buttons are not working, return to "Resetting the Wireless Control Module," and repeat the entire programming and pairing process.

MAINTENANCE

⚠ WARNING

Never remove the spreader with material in the hopper.

⚠ CAUTION

Disconnect electric power at spreader electrical wiring harness connection and tag out if required before servicing or performing maintenance.

⚠ CAUTION

- When replacing parts use only original manufacturer's parts. Failure to do so will void warranty.
- The control is a solid-state electronic unit and is not serviceable. Any attempt to service will void warranty.
- There are no serviceable parts in the motor/transmission assembly. Any attempt to service will void warranty.
- When pressure washing motor enclosure area, keep spray at least 36" away from motor enclosures.

LUBRICATION

To keep your spreader running smoothly, observe the following recommendations:

- Lubricate bearings after every 20 hours of use.
- Apply a small amount of light oil to latches as needed.

AFTER EACH USE

⚠ CAUTION



DO NOT leave unused material in hopper. Material can freeze or solidify, causing unit to not work properly. Empty and clean after each use.

- Wash out the hopper and rinse off all external surfaces.
- Apply dielectric grease on all electrical connections to prevent corrosion.

AT THE END OF EACH SEASON OR AFTER EXTENDED STORAGE

- Wash out the hopper and rinse off all external surfaces.
- Apply dielectric grease on all electrical connections to prevent corrosion.
- Lubricate all grease fittings with good quality multipurpose grease.
- Oil or paint all bare metal surfaces.
- If motor cover is removed for any reason, use silicone sealant to ensure weatherproofing of enclosure.

STORAGE

Store the spreader in a clean, dry location and away from direct sunlight.

TROUBLESHOOTING

TAILGATE SPREADER

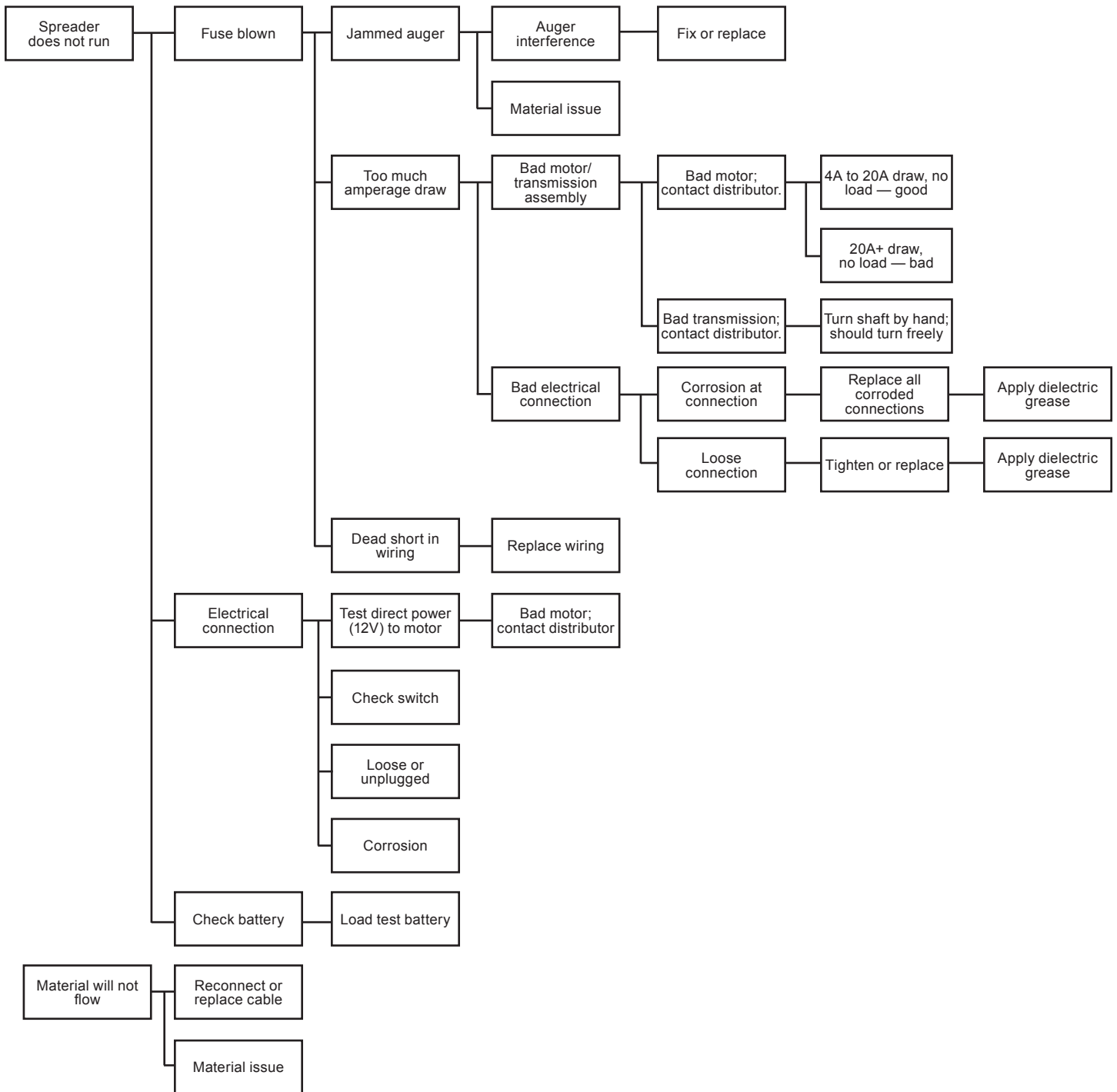

TROUBLESHOOTING

WIRELESS KEY FOB CONTROL

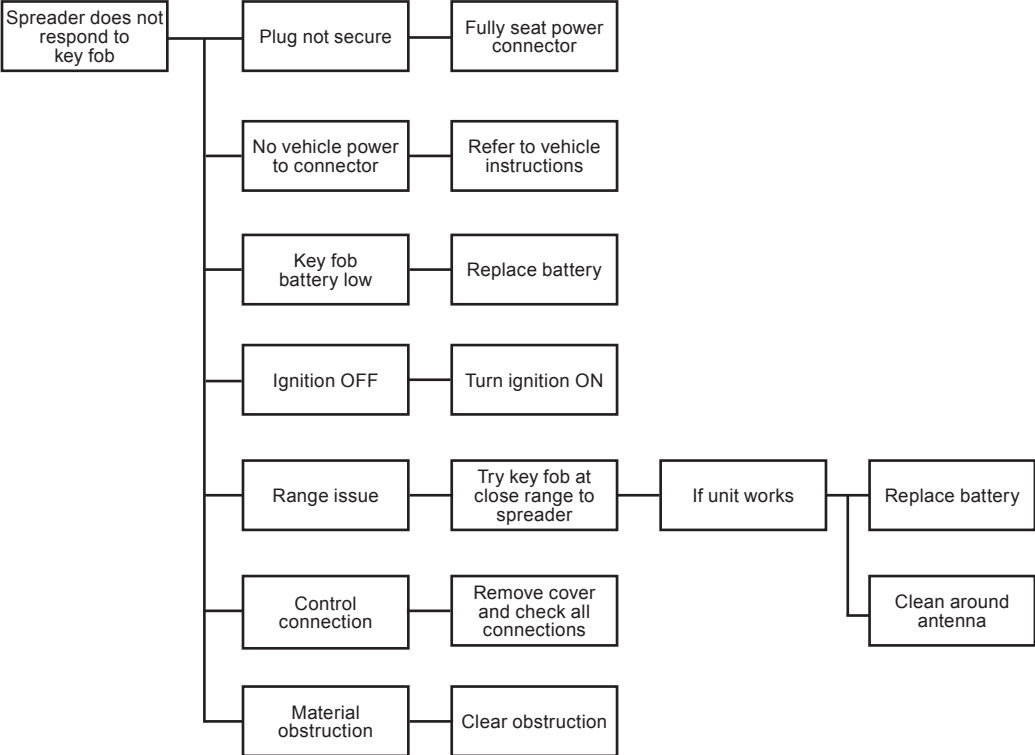

WIRELESS COMPLIANCE

This device complies with Part 15 of the FCC Rules.

Operation of this device is subject to the following two conditions:

- (1) This device may not cause harmful interference, and
- (2) this device must accept any interference received, including interference that may cause undesired operation.

This equipment has been tested and found to comply with the limits for a Class B digital device, pursuant to Part 15 of the FCC Rules. These limits are designed to provide reasonable protection against harmful interference in a residential installation. This equipment generates, uses, and can radiate radio frequency energy and, if not installed and used in accordance with the instructions, may cause harmful interference to radio communications. However, there is no guarantee that interference will not occur in a particular installation.

If this equipment does cause harmful interference to radio or television reception, which can be determined by turning the equipment off and on, the user is encouraged to try to correct the interference by one or more of the following measures:

- Reorient or relocate the receiving antenna.
- Increase the separation between the equipment and receiver.
- Connect the equipment into an outlet on a circuit different from that to which the receiver is connected.
- Consult the dealer or an experienced radio/TV technician for help.

This equipment has been certified to comply with the limits for a Class B computing device, pursuant to FCC Rules. In order to maintain compliance with FCC regulations, shielded cables must be used with this equipment. Operation with non-approved equipment or unshielded cables is likely to result in interference to radio or TV reception. The user is cautioned that changes and modifications made to the equipment without the approval of the manufacturer could void the user's authority to operate this equipment.

The actual size labels below must be located on the spreader to comply with FCC Rules.

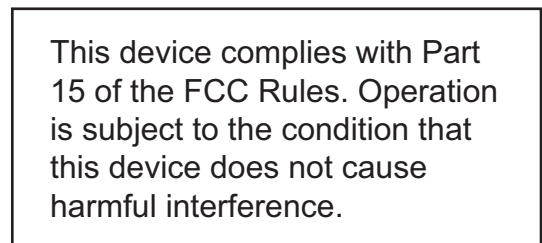
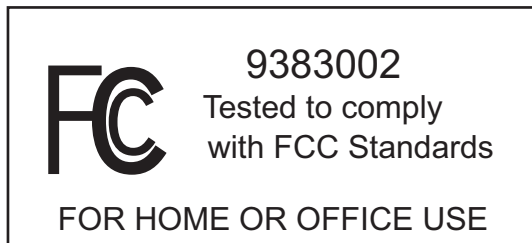



TrynEx International
531 Ajax Drive
Madison Heights, MI 48071-2429
www.snowexproducts.com

 A DIVISION OF DOUGLAS DYNAMICS, LLC

Copyright © 2018 Douglas Dynamics, LLC. All rights reserved. This material may not be reproduced or copied, in whole or in part, in any printed, mechanical, electronic, film, or other distribution and storage media, without the written consent of TrynEx International, LLC. Authorization to photocopy items for internal or personal use by TrynEx International, LLC outlets or spreader owner is granted.

TrynEx International, LLC reserves the right under its product improvement policy to change construction or design details and furnish equipment when so altered without reference to illustrations or specifications used. TrynEx International, LLC or the vehicle manufacturer may require or recommend optional equipment for spreaders. Do not exceed vehicle ratings with a spreader. Patent pending. TrynEx International, LLC offers a limited warranty for all spreaders and accessories. See separately printed page for this important information. The following are registered (®) trademarks of Douglas Dynamics, LLC: SnowEx®, TrynEx®.

Printed in U.S.A.