



VAN SOLUTIONS
FOR THE WAY YOU WORK™

EZGlide2™

INSTALLATION MANUAL



Model 2261-3-01

Weather Guard / Knaack
420 E. Terra Cotta Ave
Crystal Lake, IL 60014 USA

800-456-7865 Toll Free
800-334-2981 Fax
Knaack.OrderEntry@wernerco.com

Weather Guard / Knaack
185A Courtneypark Drive East
Mississauga, ON L5T 2T6

888-562-2251 Toll Free
888-456-8460 Fax
Knaack.OrderEntry.Canada@wernerco.com



ATTENTION: PLEASE READ AND UNDERSTAND ALL INSTRUCTIONS AND WARNINGS BEFORE ASSEMBLING, INSTALLING OR USING THIS PRODUCT.

⚠ CAUTION

Be safe - always wear protective eye wear to keep debris out of your eyes when installing WEATHER GUARD® Van Products

⚠ WARNING

Prior to drilling, check under vehicle for fuel, tanks, fuel lines, brake lines, electric wires, etc. To avoid cutting or puncturing them. Do not use Blind Fasteners in these areas.

Tools Needed

- THREADLOCKER COMPOUND
- 1/2" SOCKET AND/OR WRENCH
- 3/16" HEX KEY/DRIVER
- 1/4" HEX KEY/DRIVER
- 2X 9/16 SOCKET AND/OR WRENCH
- 7/16" SOCKET AND/OR WRENCH
- SAW RECOMMENDED FOR RAM PROMASTER 118" WHEELBASE
- DRILL WITH 21/64" DRILL BIT RECOMMENDED FOR RAM PROMASTER 118" WHEELBASE
- TORQUE SETTABLE DRIVER OR TORQUE WRENCH.
- IMPACT WRENCH (OPTIONAL)

BEFORE YOU BEGIN

The EZGLIDE2™ drop-down ladder rack is designed to work with OEM side gutters or with Weather Guard Mounting Channel kits to provide the best support for your ladders and to take advantage of OEM provided roof mounting points. If you have not already installed the mounting channel kit to the van roof, install it now before proceeding.

If you are installing this product on a van with OEM side gutters, you do not need to use a mounting channel kit.

CONTENTS

EZGLIDE2™ PARTS LIST	4
STEP 1 INSTALL VERTICAL TUBE AND DAMPER	6
STEP 2 INSTALL LADDER HOOKS	7
STEP 3 MOUNT MOUNTING FEET TO CROSS MEMBERS	8
STEP 4 INSTALL CURVED MOUNTING BRACKETS	9
STEP 5 INSTALL DROP DOWN MECHANISMS TO CROSS MEMBERS.....	10
STEP 6 MOUNT CROSS MEMBERS TO VEHICLE	11
STEP 7 INSTALL CENTER CONNECTING TUBE AND FRONT CROSS MEMBER	12
STEP 8 INSTALL REAR DRIVE TUBE	13
STEP 9 INSTALL REAR COUPLING.....	13
STEP 10 POSITION AND SECURE LADDER RACK ASSEMBLY.....	14
STEP 11 INSTALL ACCESSORY VERTICAL TUBES AND FRONT RED CAP	14
EZGLIDE2™ SPARE PARTS LIST	15

EZ GLIDE2™ PARTS LIST

DESCRIPTION	QTY
FIXED DROP DOWN	2
89" CONNECTING TUBE	1
REAR DRIVE TUBE	1
REAR COUPLING	1
MOUNTING FOOT	4
VERTICAL LADDER STOP	4
DAMPER	2
TELESCOPIC HANDLE	1
70" CROSS-MEMBER	2
FIXED LADDER HOOK	2

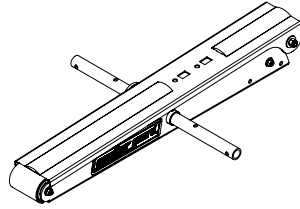

FIXED DROP DOWN

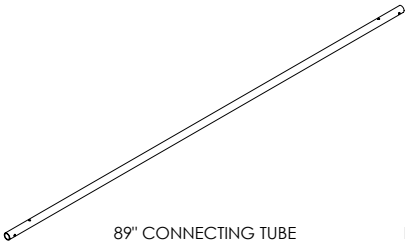

89" CONNECTING TUBE



REAR DRIVE TUBE



REAR COUPLING



MOUNTING FOOT

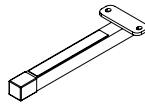

VERTICAL LADDER STOP

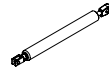

DAMPER

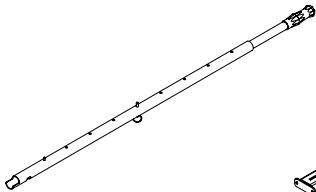

TELESCOPING HANDLE

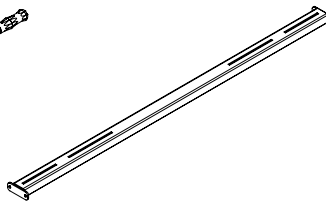

70" CROSSMEMBER

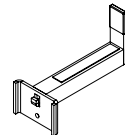

FIXED LADDER HOOK

DESCRIPTION	QTY
5/16" WASHER	38
5/16 x 1-3/4" BOLT	6
5/16 x 2" SCREW	8
RED CAP	1
1" SPACER	4
5/16 NYLON LOCK NUT	30
3/8 WASHER	1
3/8 x 7/8" BOLT	1
3/8 NYLON LOCK NUT	1
STUD PLATE	4
1/4 WASHER	8
1/4 NYLON LOCK NUT	8
COUPLING BUSHING	1
CLEVIS PIN	1
5/16 x 3/4" CARRIAGE BOLT	16
E-CLIP	2
DAMPER ROD	2
LOOP CLAMP	1
SPRING CLIP	2
5/16 x 1-1/4" BOLT	4
CURVED MOUNTING BRACKET	4
MOUNTING FOOT BOLT PLATE	4



5/16" WASHER



5/16X1-3/4" BOLT



5/16X2" SCREW

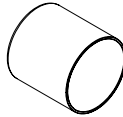

RED CAP



1" SPACER



5/16" NYLON LOCK NUT



3/8" WASHER



3/8X5/8" BOLT



3/8" NYLON LOCK NUT

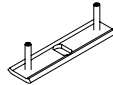

STUD PLATE



1/4" WASHER



1/4" NYLON LOCK NUT

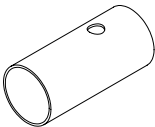

COUPLING BUSHING

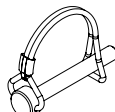

CLEVIS PIN



5/16X3/4" CARRIAGE BOLT



E-CLIP

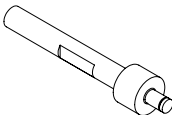

DAMPER ROD



LOOP CLAMP



SPRING CLIP



5/16X1-1/4" BOLT

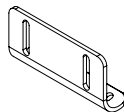

CURVED MOUNTING BRACKET

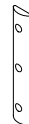

MOUNTING FOOT BOLT PLATE

STEP 1 - INSTALL VERTICAL TUBE AND DAMPER

Using the damper, damper rod and 1-e-clip, install the eyelet end of the damper to the damper rod using 1-e-clip. The damper comes with a preinstalled clip on the clevis end side. Remove clip, slide clevis end over the drive tube cam, and reinstall clip.

Using 2-5/16x2" screws, 2-1" spacers, 1-5/16" nylon lock nut, 1-5/16" washer, and 1-damper rod, install the vertical ladder stop to each drop down unit. The inner mounting point will use the 5/16" washer and nut, While the outer mounting point will use the damper rod for the 5/16x2" screw. It is recommended to use thread locking compound on the 5/16x2" screw that threads into the damper rod. Torque both the 5/16" nut and damper rod to 17 ft-lbs.

Repeat with the other drop down unit.

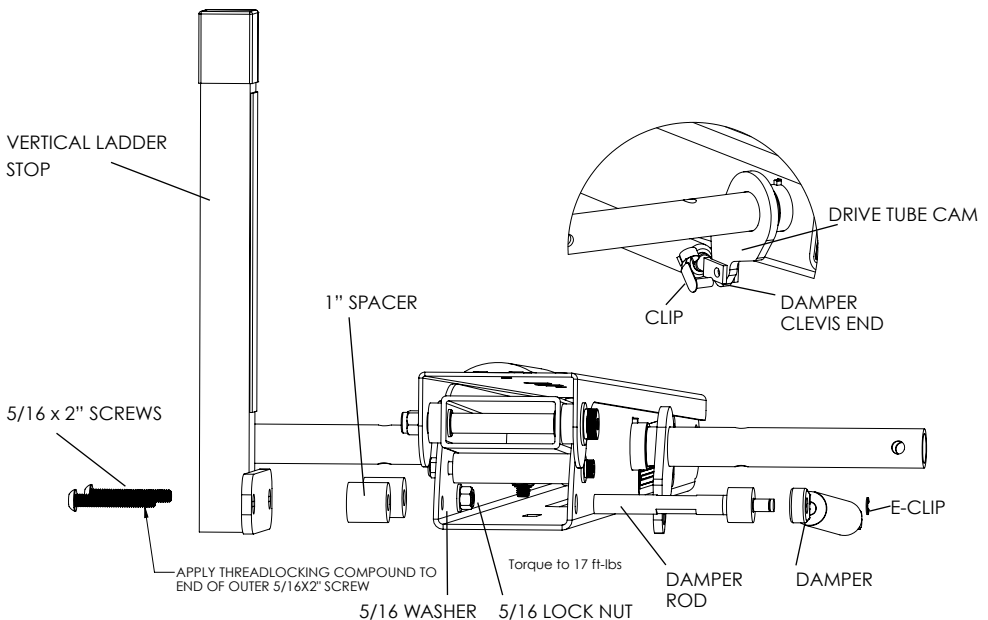

STEP 2 - INSTALL LADDER HOOKS

Using 1-3/8x5/8" bolt, 1-3/8" nylon lock nut, and 2-3/8" washers install the fixed ladder hook to the drop down unit. The hook should be located according to the diagram in the upper set of holes, but may be adjusted depending on ladder dimensions and user preference. Torque nut to 30 ft-lbs.

Repeat for second drop down unit.

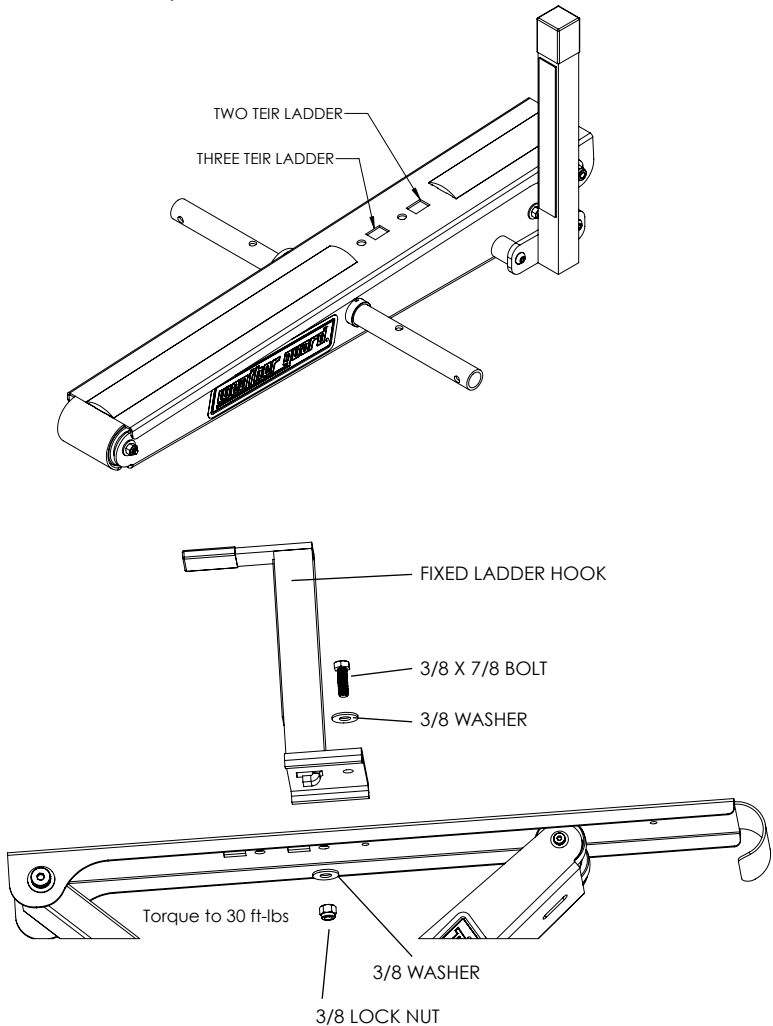

STEP 3 - MOUNT MOUNTING FEET TO CROSS MEMBERS

Only use one carriage bolt, washer, and nut per mounting foot.

Using 1-5/16x3/4" carriage bolt, 1-5/16" washer, and 1-5/16" nylon lock nut per mounting foot, install two mounting feet per cross member. Please refer to the table and diagram for mounting foot location and orientation.

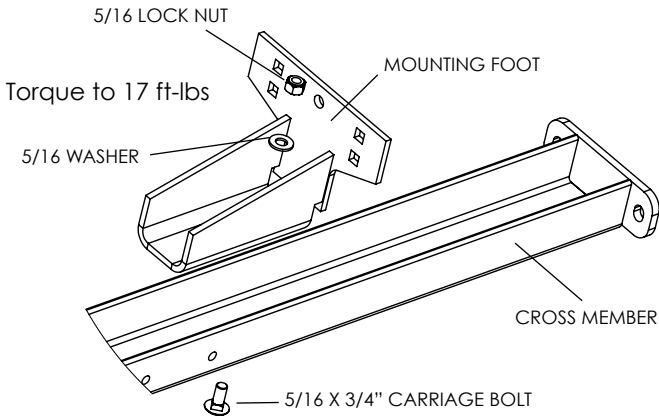

INSTALL MOUNTING FEET ACCORDING TO TABLE

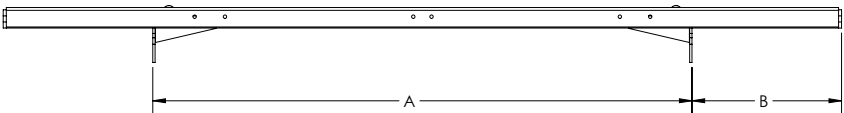

MOUNTING FOOT DISTANCE		
VEHICLE	DIM "A"	DIM "B"
FORD TRANSIT CONNECT (FRONT)	46-1/4"	6-3/8"
FORD TRANSIT CONNECT (REAR)	47-1/4"	5-7/8"
RAM PROMASTER CITY (FRONT)	42"	8-1/2"
RAM PROMASTER CITY (REAR)	41-3/8"	8-13/16"
CHEVY CITY EXPRESS	45-3/8"	6-13/16"
NISSAN NV200	45-3/8"	6-13/16"

STEP 4 - INSTALL CURVED MOUNTING BRACKETS

Using 2-5/16X3/4" carriage bolt, 2-5/16" washer, and 2-5/16" nylon lock nut per mounting foot install a curved mounting bracket to each mounting foot. Torque nuts to 17 ft-lbs.

If using an impact driver to torque nuts, it is recommended that the carriage bolt orientation be reversed to engage the square cut outs in the mounting foot.

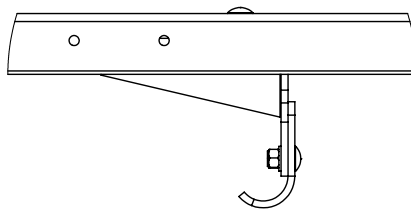
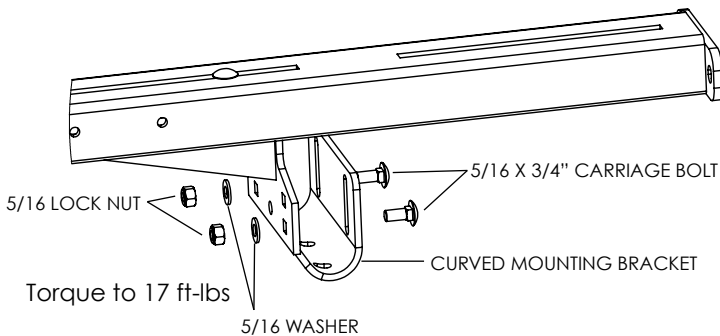

Most vehicle installations will benefit from having the lowest installed height with the mounting bracket lining up with the start of the curve on the curved mounting bracket. Due to vehicle roof curvatures some adjustment for final assembly height may be required after the crossmembers are installed on the roof.

STEP 5 - INSTALL DROP DOWN MECHANISMS TO CROSS MEMBERS

Using 2-5/16x3/4" carriage bolt, 2-5/16" washer, and 2-5/16" nylon lock nut per drop down mechanism, install each drop down mechanism to the cross members. The end of the bottom bracket on the drop down mechanism should line up with the end of the cross member. Torque nuts to 17 ft-lbs.

On single side installations, there will be one drop down mechanism per cross member. On dual drop down setups, you may install two mechanisms per cross member.

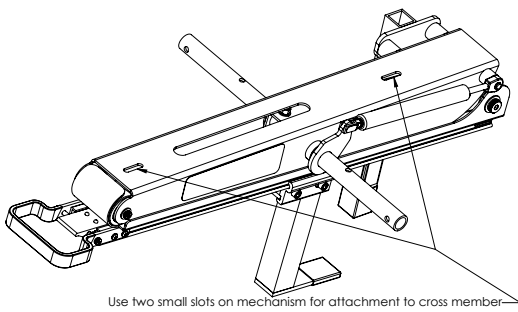
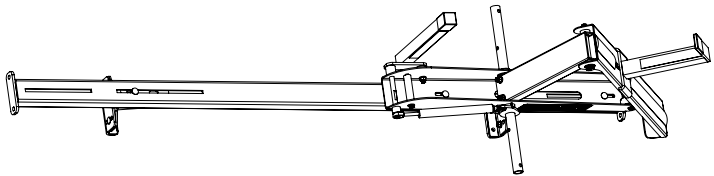

Use two small slots on mechanism for attachment to cross member

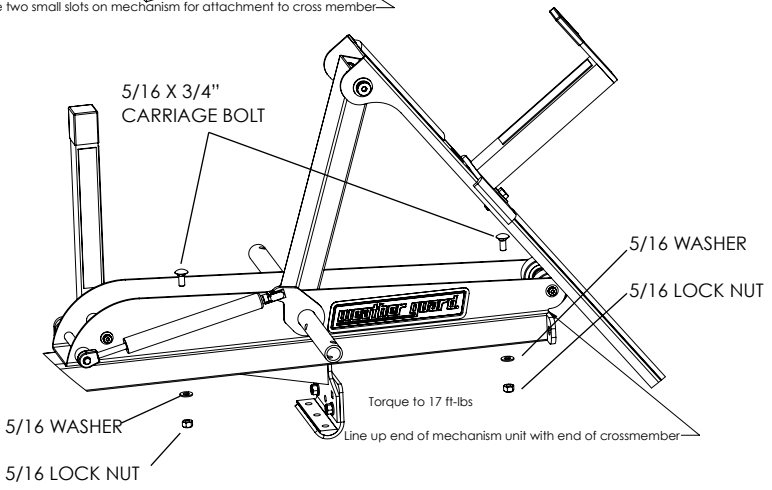

STEP 6 - MOUNT REAR CROSS MEMBERS TO VEHICLE

Slide two stud plates per mounting channel into mounting channel if not already done. If installing a dual setup with 3 cross members, 3 stud plates will be used per mounting channel. Using 2-1/4" washers, 2-1/4" nylon lock nuts, and 1 mounting foot bolt plate per mounting foot, install the rear cross member on the mounting channel. The cross member that has the slide down mechanism should be installed in the rear position.

The EZ GLIDE2 can be installed on either the street side or curb side of the van. Decide which side to install the drop-down before mounting it to the vehicle.

Locate the cross member approximately 1-3" from the end of the mounting channel and hand tighten each 1/4" nut. The 1/4" nuts will need to be kept loose until step 7 is complete.

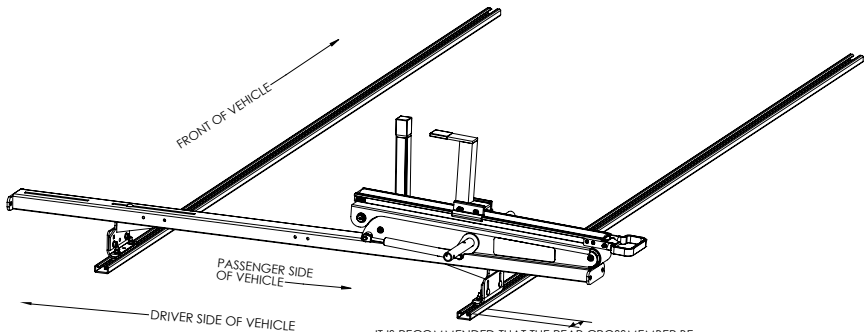
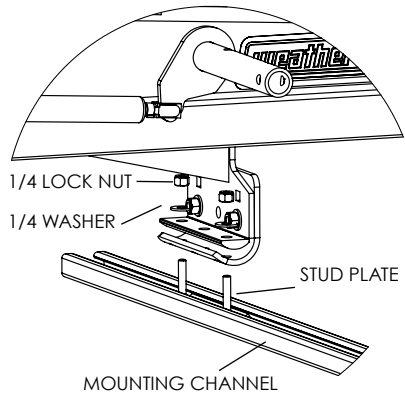

IT IS RECOMMENDED THAT THE REAR CROSSMEMBER BE LOCATED APPROXIMATELY 1-3" FROM THE REAR OF THE MOUNTING CHANNEL

STEP 7 - INSTALL CENTER CONNECTING TUBE AND FRONT CROSS MEMBER

Rotate and position the connecting tube on the drive tube until all 4 mounting holes line up. Using 2-5/16x1-3/4" bolts, 4-5/16" washers, and 2-5/16" nuts, install the connecting tube. Torque 5/16 nuts to 17 ft-lbs.

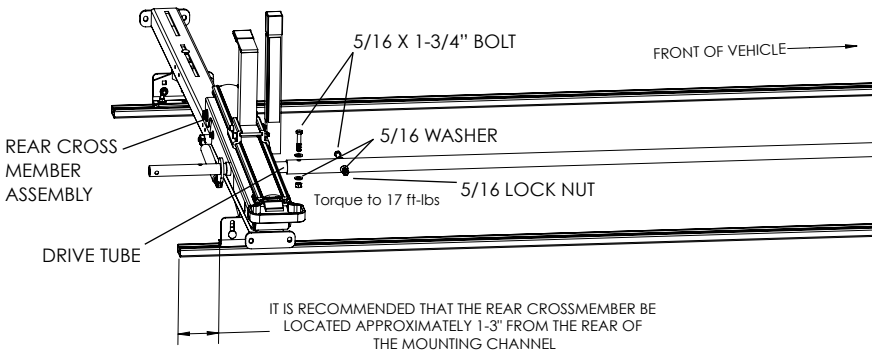

Using 2-5/16x1-3/4" bolts, 4-5/16" washers, and 2-5/16" nuts, install the connecting tube on the front drive tube. Rotate and position the center connecting tube until all 4 mounting holes line up and then drop cross member onto stud plates. Torque 5/16 nuts to 17 ft-lbs.

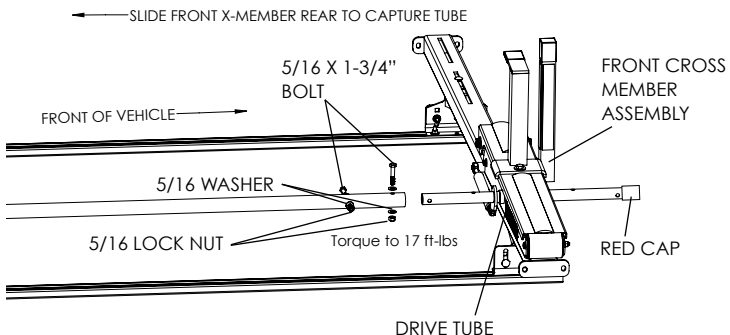

On Ford Transit installations it is ok to place the curved mounting bracket on top of the mounting channel end caps and pinch them between the mounting channels.

STEP 8 - INSTALL REAR DRIVE TUBE

Using 2-5/16x1-3/4" bolts, 4-5/16" washers, and 2-5/16" nylon lock nuts, install the drive tube to the rear drop down mechanism. Rotate and position tube until all 4 mounting holes line up and torque nuts to 17 ft-lbs.

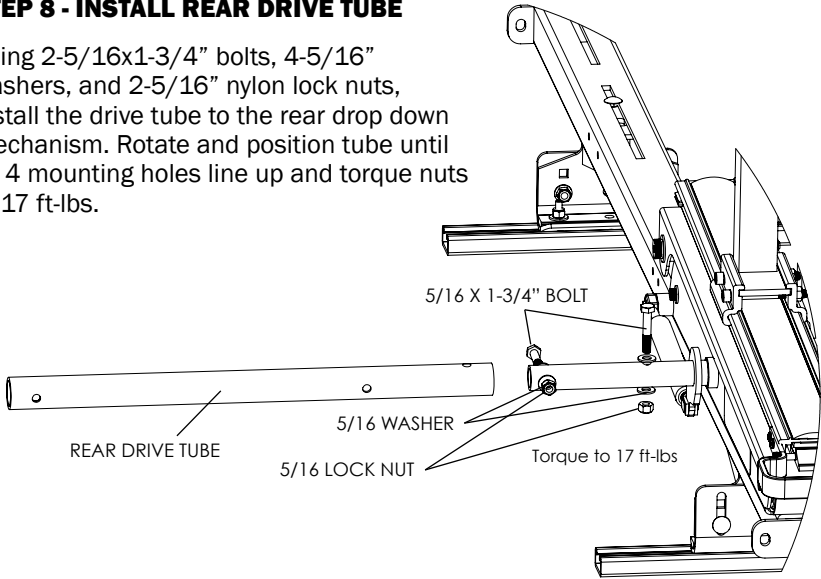

STEP 9 - INSTALL REAR COUPLING

Install the rear coupling to the drive tube using the coupling bushing and clevis pin. The coupling should be installed with the red cap on top and the open end pointing AWAY from the center of the van.

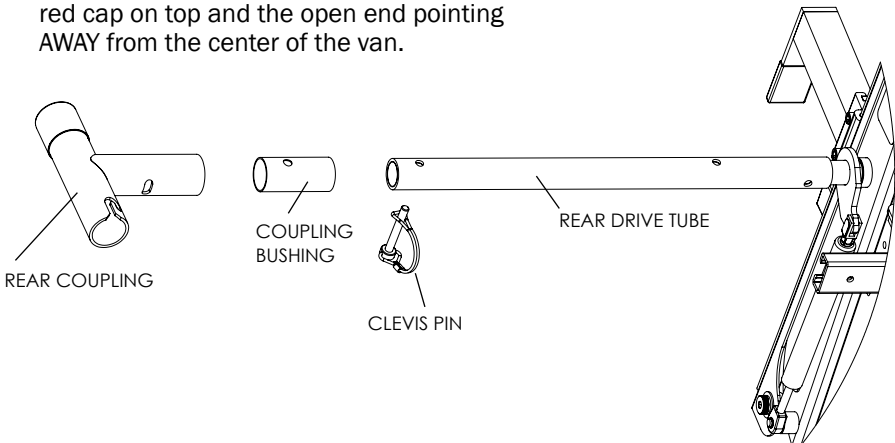

STEP 10 - POSITION AND SECURE LADDER RACK ASSEMBLY

Insert the handle into the rear coupler and ensure there is sufficient clearance between the back of the vehicle and the handle for full rotation. If more or less clearance is desired slide the rack forward or backwards in the mounting channels. Once the desired position is found, torque all 1/4" nuts to 8 ft-lbs to lock the position of the rack.

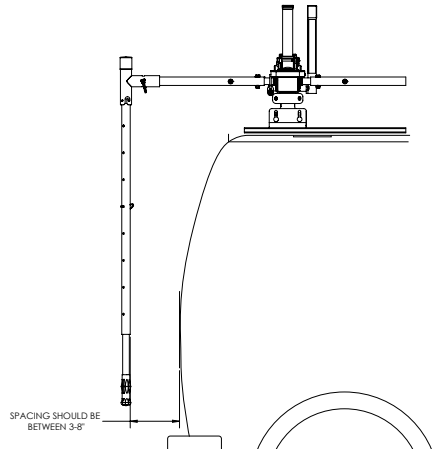

STEP 11 - INSTALL ACCESSORY VERTICAL LADDER STOPS

Using 2-5/16x1-1/4" bolts, 4- 5/16" washers, and 2-5/16" nylon lock nuts per vertical ladder stop, install 1 vertical ladder stop at the end of each cross member. Torque nuts to 17 ft-lbs.

If a dual side setup was installed do not install the ladder stops.

Your drop down ladder rack also includes two spring clips that may be installed to the inside of the van, that allow the handle to be safely stored when the handle is not in use.

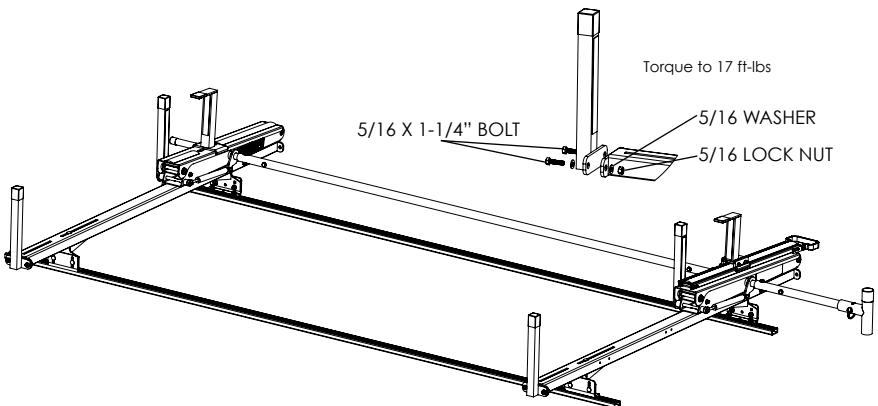

2261-3-01 EZGLIDE²™ SERVICE PARTS

PART NO	DESCRIPTION	FITS MODEL NUMBER
70512	REPLACEMENT 70" CONNECTING TUBE FOR EZGLIDE ² ™ DROP-DOWN VAN RACK	2261-3-01, 2265-3-01
70513	REPLACEMENT 36" CONNECTING TUBE FOR EZGLIDE ² ™ DROP-DOWN VAN RACK	2267-3-01, 2265-3-01, 2267-3-01
70514	REPLACEMENT LADDER STOP KIT FOR EZGLIDE ² ™ DROP-DOWN VAN RACK	ALL MODELS
70515	REPLACEMENT LADDER HOOK KIT FOR EZGLIDE ² ™ FIXED DROP-DOWN MECHANISM	ALL MODELS
70517	REPLACEMENT BOLT KIT FOR MOUNTING CHANNEL KIT, 85 IN	2085-0-01
70520	REPLACEMENT RED PLASTIC CAP KIT FOR EZGLIDE ² ™ DROP-DOWN VAN RACK	ALL MODELS
70521	REPLACEMENT REAR HANDLE KIT FOR EZGLIDE ² ™ DROP-DOWN VAN RACK	ALL MODELS
70522	REPLACEMENT RUB STRIP KIT FOR EZGLIDE ² ™ FIXED DROP-DOWN MECHANISM	ALL MODELS
70524	REPLACEMENT DAMPER FOR EZGLIDE ² ™ DROP-DOWN VAN RACK	ALL MODELS
70528	REPLACEMENT BOLT KIT FOR MODEL 2271-3-01 EZGLIDE ² ™ DROP-DOWN VAN RACK	2271-3-01, 2261-3-01
70529	REPLACEMENT BOLT KIT FOR MODEL 2275-3-01 EZGLIDE ² ™ DROP-DOWN VAN RACK	2275-3-01, 2265-3-01
70530	REPLACEMENT BOLT KIT FOR MODEL 2277-3-01 EZGLIDE ² ™ DROP-DOWN VAN RACK	2277-3-01, 2267-3-01
70532	REPLACEMENT EZGLIDE ² ™ FIXED DROP-DOWN MECHANISM	ALL MODELS
70533	REPLACEMENT BUSHING KIT FOR EZGLIDE ² ™ DROP-DOWN VAN RACK	ALL MODELS



KNAACK LLC LIMITED LIFETIME WARRANTY FOR WEATHER GUARD® PRODUCTS

WEATHER GUARD® Products – Limited Lifetime Warranty (Purchased on or after 1/1/2009)

Knaack LLC (the “Manufacturer”) warrants to the original purchaser only that WEATHER GUARD® Truck and Van Products (the “WEATHER GUARD® Product”) will be free from defects in material and workmanship from the date of purchase and continuing for the expected lifetime of the WEATHER GUARD® Product. A copy of the original sales receipt must be supplied to the Manufacturer at the time a warranty claim is made. This warranty terminates if the original purchaser transfers the WEATHER GUARD® Product to any other person.

What is Covered

All WEATHER GUARD® Products identified above that are purchased on or after January 1, 2009.

What We Will Do to Correct Problems

Subject to the limitations and exclusions described in this limited warranty, the Manufacturer will remedy defects in materials or workmanship by providing one of the following remedies at its option and without charge to the original purchaser for parts or labor: (a) repairing the defective portion of the WEATHER GUARD® Product or (b) replacing the entire WEATHER GUARD® Product. In addition, the manufacturer may elect at its option, not to repair or replace the WEATHER GUARD® Product, but rather issue to the original purchaser a refund equal to the purchase price paid for the WEATHER GUARD® Product or a credit to be used toward the purchase of new WEATHER GUARD® Product.

What is Not Covered

This limited warranty expressly excludes:

- Defects caused by normal wear and tear, cosmetic rust, scratches, accidents, unlawful vehicle operation, or modification to the product, or any types or repair of a WEATHER GUARD® Product other than those authorized or provided by the Manufacturer.
- Defects resulting from conditions beyond the Manufacturer’s control including, but not limited to misuse, overloading, or failure to assemble, mount or use the WEATHER GUARD® Product in accordance with the Manufacturer’s written instructions or guidelines included with the WEATHER GUARD® Product or made available to the original purchaser.
- Damage to the contents of the box or vehicle.
- TO THE EXTENT PERMITTED BY LAW, IN NO EVENT SHALL THE MANUFACTURER BE LIABLE FOR ANY INCIDENTAL, SPECIAL, INDIRECT, OR CONSEQUENTIAL DAMAGES, INCLUDING ANY ECONOMIC LOSS, WHETHER RESULTING FROM NONPERFORMANCE, USE, MISUSE OR INABILITY TO USE THE WEATHER GUARD® PRODUCT OR THE MANUFACTURER’S NEGLIGENCE.

No Other Express Warranty Applies

This Limited Lifetime Warranty is the sole and exclusive warranty for WEATHER GUARD® Products. No employee, agent, dealer, or other person is authorized to alter this warranty or make any other warranty on behalf of Knaack LLC.

Notification Procedures

If the WEATHER GUARD® Product does not conform with the terms of this limited warranty, the original owner must promptly notify the Manufacturer in writing upon discovery of the nonconformity. In order to receive the remedies under this limited warranty, the warranty claim must describe the nature of the nonconformity, and a copy of the original sales receipt, invoice, bill or other proof of purchase must accompany the claim. Repairs or modifications made to the WEATHER GUARD® Product by other than the Manufacturer or its authorized agent will nullify this limited warranty. Coverage under this limited warranty is conditioned at all times upon the owner’s compliance with these required notification and repair procedures. Warranty claims must include reciprocal contact information and may be made via certified mail to:

**Knaack LLC
ATTN: Warranty Claims
420 E. Terra Cotta Avenue Crystal Lake, IL 60014**

If you have any questions, please call toll free at 1-800-456-7865.

©2015 Knaack LLC

