

## High Bay/Low Bay Passive Infrared Dimming Occupancy Sensor with Daylight Sensing and Offset Adaptor

Cat. Nos. HB011-PDX, HB011-PD2, HB011-BDX, HB011-BD2

### Ratings:

HB011-PDX, HB011-BDX: 120-230-277V, 50/60Hz  
HB011-PD2, HB011-BD2: 347V, 60Hz

### Load Rating (one hot leg, same phase only):

800 W tungsten load @ 120 VAC – 1200 W tungsten load @ 277 VAC  
120V, 8A Electronic Ballast – 277V, 5A Electronic Ballast – 1500 VA @ 347 VAC (Ballast only)  
Motor Load: 1/4 HP

### Dimming Loads:

1-10VDC dimmable ballasts or LED drivers only  
Sinks 20 mA maximum (~ 40 LED drivers/ballasts @ 0.5 per)  
Minimum Load: .1mA

## WARNING AND CAUTIONS

- **TO AVOID FIRE, SHOCK, OR DEATH: TURN OFF POWER AT CIRCUIT BREAKER OR FUSE AND TEST THAT THE POWER IS OFF BEFORE WIRING.**
- **TO AVOID FIRE, SHOCK, DEATH, OR DAMAGE TO PROPERTY, DO NOT CONTROL A LOAD IN EXCESS OF THE SPECIFIED RATINGS. CHECK YOUR LOAD RATINGS TO DETERMINE THE UNIT'S SUITABILITY FOR YOUR APPLICATION.**
- IF YOU ARE NOT SURE ABOUT ANY PART OF THESE INSTRUCTIONS, CONSULT AN ELECTRICIAN.

## FEATURES

- Fixture or electrical box mounted Passive Infrared Occupancy Sensor
- Integrated PhotoCell
- Adjustable Time Delay
- Auto Calibration
- Pre-stripped color coded wire leads  
21" length (HB011-PDX, PD2) - 42" length (HB011-BDX, BD2)
- Optional aisle mask
- 1-10V Dimming
- Partial OFF modes
- Adjustable PIR sensitivity
- Ladderless daylighting configuration
- Visual LED indications for easy troubleshooting
- 360° field-of-view for 20 ft. to 40 ft. High Bay mounting heights
- 360° field-of-view for 8 ft. to 20 ft. Low Bay mounting heights
- H.I.S. (High Inrush Stability) Technology
  - Zero Crossing
  - Robust Mechanical Latching Relays
- LED indicator light blinks when sensor detects motion, visible from long distance
- False Detection Filtering
- Rapid response to vehicles
- Offset Adaptors (sold separately) positions sensor at optimum field-of-view

## DESCRIPTION

Leviton's High Bay Occupancy Sensors, Cat. No. HB011, are specifically designed for high mounted areas such as warehouses, manufacturing and other high ceiling applications. The HB011 installs directly to an industrial luminaire or an electrical junction box. It is a self-contained sensor and relay that detects motion using the passive infrared (PIR) to sense sources (such as a person entering a room) within its field-of-view (monitored space) and automatically switches lights ON. The controlled lights will remain ON until no motion is detected and the scheduled time-delay has expired. The daylight sensor is sensitive to ambient light and has a threshold level that can be user-adjusted. The HB011 is supplied with two interchangeable lens rings that allows the user to select between a 360 degree High Bay or Low Bay pattern and an aisle pattern with the included aisle mask.

The Sensor's High Bay lens and aisle lens is designed for 20 ft. to 40 ft. mounting heights for a symmetrical pattern which will provide coverage of 50' to 60' diameter (refer to Figure 4 and 5). The Low Bay lens is designed for 8 ft. to 20 ft. mounting heights for a symmetrical pattern which will provide coverage of 30' to 50' diameter (refer to Figure 6). The Sensor is sensitive to the heat emitted by the human body. In order to initially trigger the Sensor, the source of heat must move from one zone of detection to another.

Note that occupancy sensors respond to rapid changes in temperature, so care should be taken not to mount the device near a climate control source (i.e. radiators, air exchanges, and air conditioners). Hot or cold drafts will look like body motion to the device and will trigger it if the unit is mounted too close.

**Mount the Occupancy Sensor 6 ft. away from the heating or cooling ventilation source.**

## INSTALLATION

**NOTE:** The HB011 is supplied with two lens trim rings. The 360 degree High Bay lens (white color trim ring) and the 360 degree Low Bay lens (blue color trim ring) in the carton. An aisle mask is included for aisle coverage if desired. Change the lens for use in aisle or Low Bay applications. See below for changing lens trim ring. The HB011 Sensor mounts in a 1/2" knock out hole on the end of a luminaire or an electrical box. The Sensor's field-of-view may be partially obstructed by the luminaire housing (refer to Figure 1A). At higher mounting heights, the outer beams are not used. As long as the bottom of the sensor is mounted within 1" from the bottom of the luminaire, the field-of-view will not be affected (refer to Figure 1B).

**ADAPTER NOTE:** For deep bodied luminaires or to clear other obstructions use Leviton's OSFOA-00W Adapter. The Adapter is designed to provide multiple mounting positions to accommodate different mounting heights for optimum sensor positioning. A keyed, threaded snap-in nipple that holds the Adapter in place while tightening the provided lock-nut. The OSFLO is a single height position adapter with a quick install snap in fitting without a lock nut (refer to Figures 2A and 2B).

## CHOOSE LENS

1. To change lens, turn trim ring so that the two indented dots line up and pull out by the finger tabs (refer to Figure 7A).
2. Remove the inner lock-nut from the threaded nipple and insert the wires and the threaded nipple into a half inch hole of the luminaire body or the electrical box.
 

**NOTE:** Mounting nipple has a "snap" feature for quick installation into round or "double-D" holes, as well as a "keying" mechanism to prevent rotation after installation in "double-D" holes.
3. Slide the lock-nut over the wires and thread clockwise onto the threaded nipple to secure the sensor firmly in place making sure the lens is orientated towards the area to be monitored (field-of-view) (refer to Figure 3).
4. Connect wires per **Wiring Diagram** as follows: RED leads to LOAD; WHITE leads to NEUTRAL; BLACK leads to LINE (Hot). Connect 1-10V dimming wires (Gray & Violet). Twist strands of each lead tightly and, with circuit conductors, push firmly into the appropriate wire connector. Screw connector on clockwise making sure that no bare wire shows below the connector.
5. Restore power at circuit breaker or fuse.

**NOTE:** Allow approximately 30 seconds for charge-up. If the lights turn ON and the LED blinks when a hand is waved in front of the lens, then the Sensor was installed properly. If the operation is different, refer to the **TROUBLESHOOTING SECTION**.

The Sensor is factory preset to work without any adjustments. If you desire to change the factory settings, refer to the **SETTINGS AND CALIBRATION** section.

## WARNING AND CAUTIONS

- TO BE INSTALLED AND/OR USED IN ACCORDANCE WITH ELECTRICAL CODES AND REGULATIONS.
- DISCONNECT POWER WHEN SERVICING LUMINAIRE OR CHANGING BULBS.
- USE THIS DEVICE WITH **COPPER OR COPPER CLAD WIRE ONLY**.
- DO NOT ATTEMPT TO DISASSEMBLE OR REPAIR. CLEAN OUTER SURFACE WITH A DAMP CLOTH ONLY.

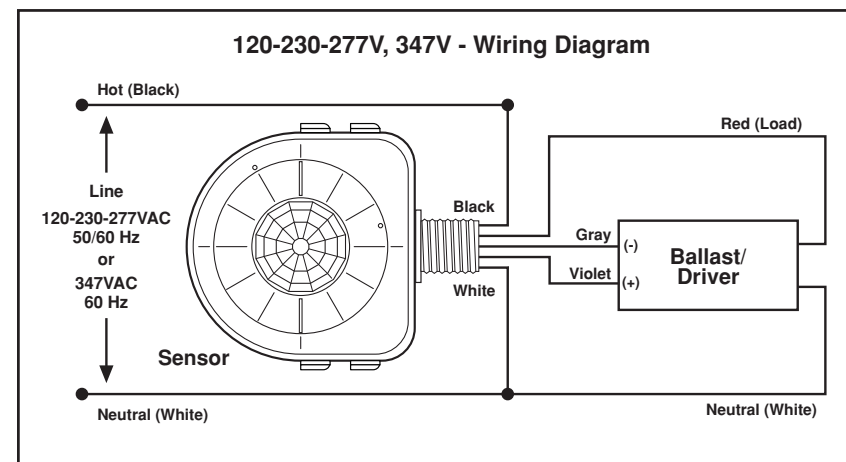

## SETTINGS AND CALIBRATION

### PhotoCell Auto Calibration

- To enable photocell or start Auto Calibration, turn the PHOTO SETPOINT knob from OFF position to any DDL setpoint (this can be done when power is removed). The LED will be solid GREEN and Lights will be forced ON for 24 hours indicating the device has entered Auto Calibration Mode.
- When Auto Calibration is complete, the LED will resume normal operation. The device is now daylighting.
- To reset to factory default, power ON the device and turn the PHOTO SETPOINT knob to OFF position for 5 seconds.

### NOTE:

- Solid BLUE LED indicates failed calibration due to ambient light falling below 5 lux during Auto Calibration.
- Failed calibration or significant change in light source like relamping requires re-calibration by resetting to factory default.
- If the calibration process does not successfully complete due to power outage, it will restart at the next power-up if the knob is not in the OFF position.
- To disable photocell or cancel Auto Calibration turn the PHOTO SETPOINT knob to OFF position.
- The DDL can be adjusted by turning the PHOTO SETPOINT knob.

FACTORY SETTINGS	
Configuration	Value
Time Delay	10 minutes
PIR Sensitivity	75% of maximum
PhotoCell Setpoint	OFF
Mode	DOFF T2 = 0
Installed Lens	White - High Bay

HB011 WIRE TABLE	
Color	Description
Black	Line
White	Neutral
Red	Load 1
Violet	1-10V + Dim Out
Gray	1-10V - Common

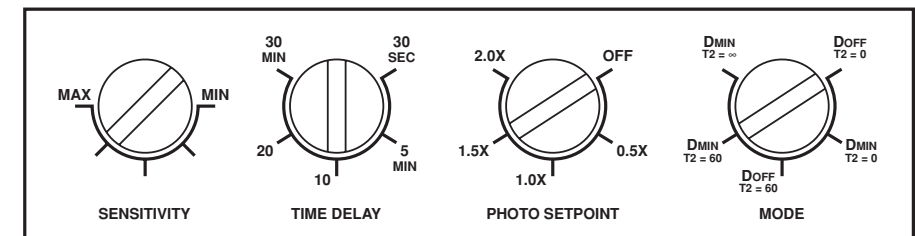

LED INDICATORS		
RED	Blink	PIR Detection
	Solid	Device Failure
GREEN	Blink 24 hr	Auto Calibration
BLUE	Blink 1x/30s	PC Hold OFF Mode
	Blink	Dial Setting Change
	Solid	Failed Calibration
YELLOW	Solid 15s	Power Time
	Blink	PhotoCell Test Mode

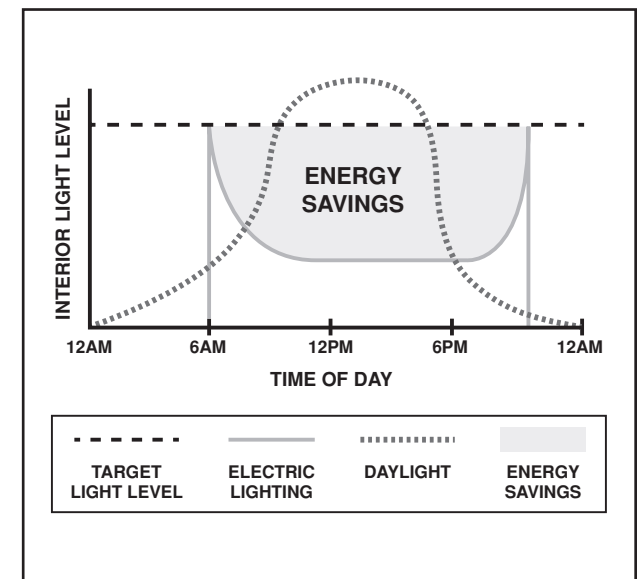

## OCCUPANCY OPERATION

Motion detection by the infrared sensor will turn the lights ON as well as keep them ON.

- **Time Delay OFF time (T1):** The sensor is designed to dim or turn the lights OFF if no motion is detected after a specified time. This length of time is called the Time Delay OFF time and is set using the TIME DELAY knob.
- **Partial OFF Time (T2):** When motion is not detected and T1 time has expired, the sensor can be configured to maintain light at minimum dim level for a period of time known as Partial OFF Time (T2). When T2 expires, lights will turn OFF.

## PHOTOCELL OPERATION

During occupancy the photocell controls a 1-10 VDC dimmable ballast or LED Driver to achieve maximum Energy savings while maintaining a minimum light level referred to as the "DDL". When no daylight is available, the photocell allows the load to operate at its full bright level. As daylight increases in the room, the photocell dims the load. When the minimum dim level is reached (and one of the Dim to Off modes is selected), the device will switch off the lights when the light level is above the DDL for 30 seconds. The lights will remain off until the light level drops below the DDL for 30 seconds. The lights will then be turned on, with the light source set at its minimum dim level. The photocell will increase the light output until the DDL is reached. As the light levels change, the photocell will reduce or increase the dim level in order to maintain the DDL. The light levels changes occurs at 5 minutes fade rate dial to make the light level transitions unnoticeable to room.

The photocell holds the lights OFF when sufficient ambient light is present if motion is detected in vacancy state.

## MODES OF OPERATION

Selectable using the MODE knob.

- MODE 1 - Doff, T2 = 0:** Daylighting Dim to OFF - Partial OFF Disabled (T2 = 0)
  - During daylighting, lights will Dim to OFF. On vacancy, lights will turn OFF after T1 expires.
- MODE 2 - Dmin, T2 = 0:** Daylighting Dim to Min - Partial OFF Disabled (T2 = 0)
  - During daylighting, lights will dim to Min. Upon vacancy, lights will turn OFF after T1 expires.
- MODE 3 - Doff, T2 = 60:** Daylighting Dim to OFF - Partial OFF Enabled (T2 = 60 min)
  - During daylighting, lights will dim to OFF. Upon vacancy, lights will dim to min after T1 expires.
  - Lights will turn OFF after 60 minutes.
- MODE 4 - Dmin, T2 = 60:** Daylighting Dim to Min - Partial OFF Enabled, (T2 = 60 min)
  - During daylighting, lights will dim to min. Upon vacancy, lights will dim to min after T1 expires.
  - Lights will turn OFF after 60 minutes.
- MODE 5 - Dmin, T2 = infinity:** Daylighting Dim to Min - Partial OFF Enabled (T2 = infinity sign)
  - During daylighting, lights will dim to min. Upon vacancy, lights will dim to min after T1 expires.
  - In this mode, lights will not turn OFF.

**NOTE:** Motion detection by the infrared sensor will reset T1 and T2.

## PHOTOCELL TEST MODE

- Can be initiated from PHOTO SETPOINT knob change and lasts for two minutes.
- While active, the dimming fade rate will be reduced to 30 seconds and LED blinks yellow.

## TROUBLESHOOTING

- **Lights do not turn ON**
  - Circuit breaker or fuse has tripped. Turn the breaker ON. Ensure the lights being controlled are in working order (i.e., working bulbs, ballasts, etc.)
  - Photocell is in override mode (light not needed). see LED Indicators Table.
  - Lens is dirty or obstructed: Inspect the lens visually and clean if necessary, or remove the obstruction.
  - Sensor is wired incorrectly or may be defective: Confirm that the sensor's wiring is done correctly and inspect visually for problems.
- **Lights stay ON**
  - The line voltage has dropped: Perform the necessary tests to ensure the line voltage has not dropped 10% beneath the specified voltage.
  - Sensor may be mounted too closely to an air conditioning or heating vent: Move the sensor or close the vent.
  - Sensor is wired incorrectly or may be defective: Confirm that the sensor's wiring is done correctly and inspect visually for problems.
- **If the lights stay ON when enough light is present check the following:**
  - Wiring and settings.
  - Poor sensor location (Ensure proper installation and re-calibrate).
  - Photocell is in failed calibration mode (Blue LED is solid ON).
  - Photocell is not calibrated.
  - DDL multiplier is set too high. Adjust DDL knob to a lower setpoint.
- **LED illuminates solid Red for longer than 5 minutes**
  - Device malfunction, Contact Technical Assistance - 1-800-824-3005

## CERTIFICATIONS

- **Line Voltage Units**
  - All models meet all requirements and pass certification testing per UL 773A and CSA 22.2 No. 205.

## FOR CANADA ONLY

For warranty information and/or product returns, residents of Canada should contact Leviton in writing at Leviton Manufacturing of Canada Ltd to the attention of the Quality Assurance Department, 165 Hymus Blvd, Pointe-Claire (Quebec), Canada H9R 1E9 or by telephone at 1 800 405-5320.

Figure 1A

### INCORRECT

Sensor mounted too high  
Outer beams are obstructed  
Field-of-view is limited

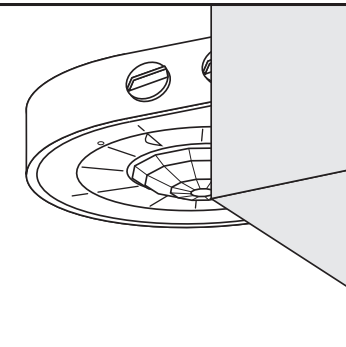

Figure 1B

### CORRECT

Sensor mounted within 1" of bottom  
No obstruction  
Optimum field-of-view

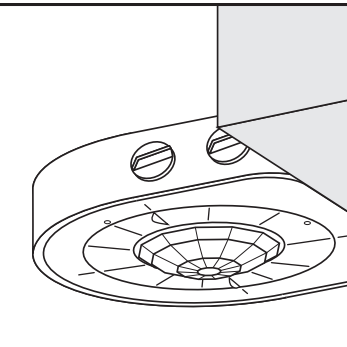
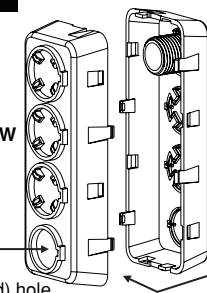

Figure 2A

### OSFOA-00W Adapter

Sensor mounts here (non-keyed) hole



Threaded snap-in nipple attaches to 1/2" luminaire or electrical box trade-size knockout holes

Alternate keyholes for height adjustment

Wires from sensor to luminaire or electrical box are fed through adapter

### OSFLO-00W Adapter

Sensor mounts here (non-keyed) hole

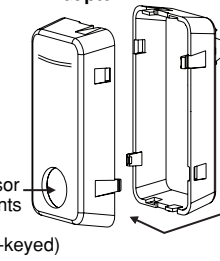

Insert nipple attaches to 1/2" luminaire or electrical box trade-size knockout holes

Wires from sensor to luminaire or electrical box are fed through adapter

Figure 2B

### OSFOA-00W Adapter (shown)

Sensor

1/2" trade-size knockout hole

Adapter allows sensor to be mounted to achieve optimum field-of-view

Figure 3

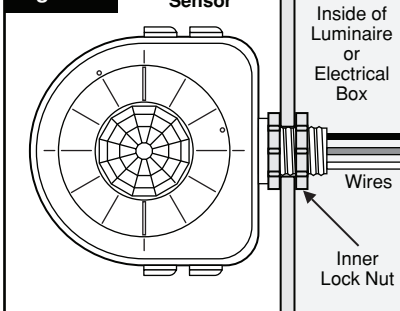

Figure 4

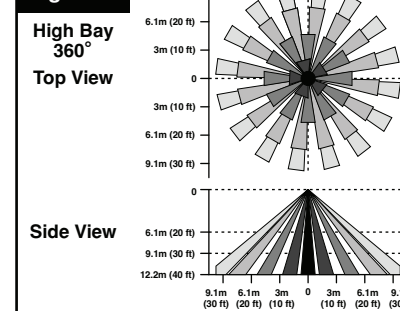

Figure 5

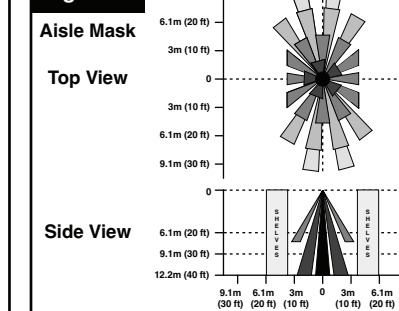

Figure 6

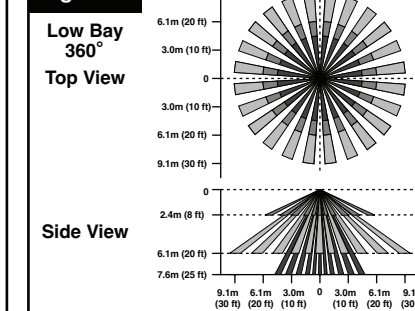

Figure 7A

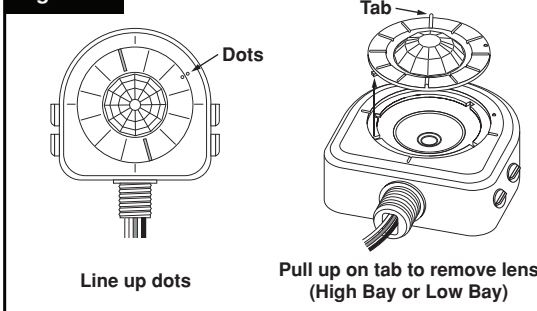
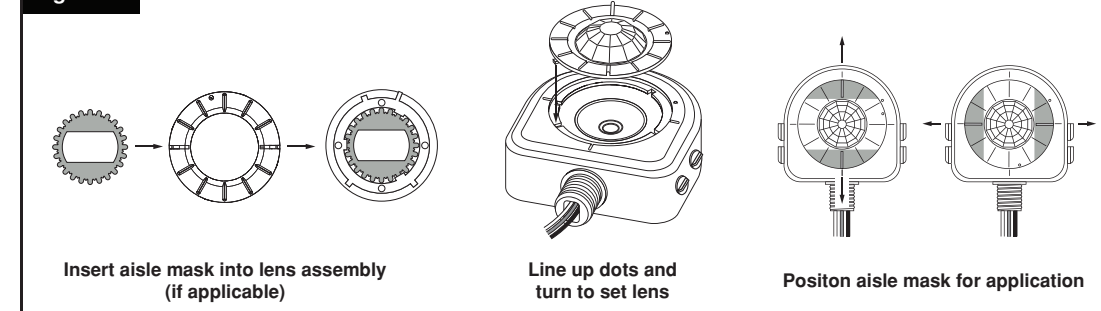

Figure 7B



## LIMITED 5 YEAR WARRANTY AND EXCLUSIONS

Leviton warrants to the original consumer purchaser and not for the benefit of anyone else that this product at the time of its sale by Leviton is free of defects in materials and workmanship under normal and proper use for five years from the purchase date. Leviton's only obligation is to correct such defects by repair or replacement, at its option. **For details visit [www.leviton.com](http://www.leviton.com) or call 1-800-824-3005.** This warranty excludes and there is disclaimed liability for labor for removal of this product or reinstallation. This warranty is void if this product is installed improperly or in an improper environment, overloaded, misused, opened, abused, or altered in such manner, or is not used under normal operating conditions or not in accordance with any labels or instructions. **There are no other or implied warranties of any kind, including merchantability and fitness for a particular purpose,** but if any implied warranty is required by the applicable jurisdiction, the duration of any such implied warranty, including merchantability and fitness for a particular purpose, is limited to five years. **Leviton is not liable for incidental, indirect, special, or consequential damages, including without limitation, damage to, or loss of use of, any equipment, lost sales or profits or delay or failure to perform this warranty obligation.** The remedies provided herein are the exclusive remedies under this warranty, whether based on contract, tort or otherwise.