

ADCRAFT®



FW-1200WR, FW-1200WR/B
**7/11 Qt. Round Food
Cooker/Warmer**

This manual contains important information regarding your *Admiral Craft* unit. Please read this manual thoroughly prior to equipment set-up, operation and maintenance. Failure to comply with regular maintenance guidelines outlined in this manual may void the warranty. MUST READ!!!

WARNINGS

- Do not touch any hot surfaces
- Do not immerse unit, cord or plug in liquid at any time
- Unplug cord from outlet when not in use and before cleaning
- Plug only into a 3-hole grounded electrical outlet
- Do not operate unattended
- Do not use this unit for anything other than intended use
- Do not use outdoors
- Always use on a firm, dry and level surface at least 12" from walls or any other obstruction
- Do not use if unit has a damaged cord or plug, in the event the appliance malfunctions, or has been damaged in any manner
- Keep children and animals away from unit
- Any incorrect installation, alterations, adjustments and/or improper maintenance can lead to property loss and injury. All repairs should be done by authorized professionals only
- Ensure that the designated power supply is adequate for continual usage and the voltage is correct
- NEVER operate this unit without water

TO USE

1. Make sure the power supply you are using is adequate.
2. Fill the well with 5 cups of water. (Do not over-fill, as if the water level is too high, water may overflow when the food pan is inserted. Overflow will enter the electrical compartment and cause a short circuit or electrical shock)
3. Plug the cord into a three hole grounded electrical outlet
4. Preheat the water in the well by covering the well with an empty food container or cover. Set the heat control to the maximum heat setting. Preheat for 30 minutes.
5. Place stainless steel food pan containing food into the food warmer
6. Reduce the setting of the knob by $\frac{1}{4}$ and monitor food temperatures closely for food safety. The United States Public Health Service recommends that food be held at a minimum of 140° F (and/or in compliance with local health codes) to prevent bacteria growth. Maintain water level at 4 quarts. Periodically, (approximately every 2 hours) remove food pan and check the water level. Add hot water if needed and adjust up or down as required by the food type.

HOT WATER AND STEAM IN THE WELL CAN SEVERELY BURN SKIN. USE PROTECTIVE GLOVES, MITTS OR POTHOLDERS WHEN REMOVING FOOD CONTAINERS OR COVERS. HOT FOOD CAN ALSO CAUSE BURNS. HANDLE FOOD CAREFULLY.

CLEANING - NOTE: To maintain cleanliness and increase service life, the food warmer should be cleaned daily. Do not immerse the food warmer in water or any other liquid, if liquid enters the electrical compartment it may cause a short circuit or electrical shock

1. Before cleaning or attempting to move food warmer, unplug and let the unit cool completely
2. Carefully empty the water from the well
3. Wipe the entire unit with a clean soft cloth until it is completely dry
4. To avoid damage to the well, do not use abrasive cleaners or scouring pads
5. If soap or chemical cleaners are used, be sure they are completely rinsed away with clear water immediately after cleaning. Chemical residue could damage or corrode the surfaces of the unit.

There are no serviceable parts within this appliance. To avoid serious injury or damage, never attempt to repair the food warmer or replace a damaged cord yourself. Contact a professional repair service.

FW-1200WR
FW-1200WR/B

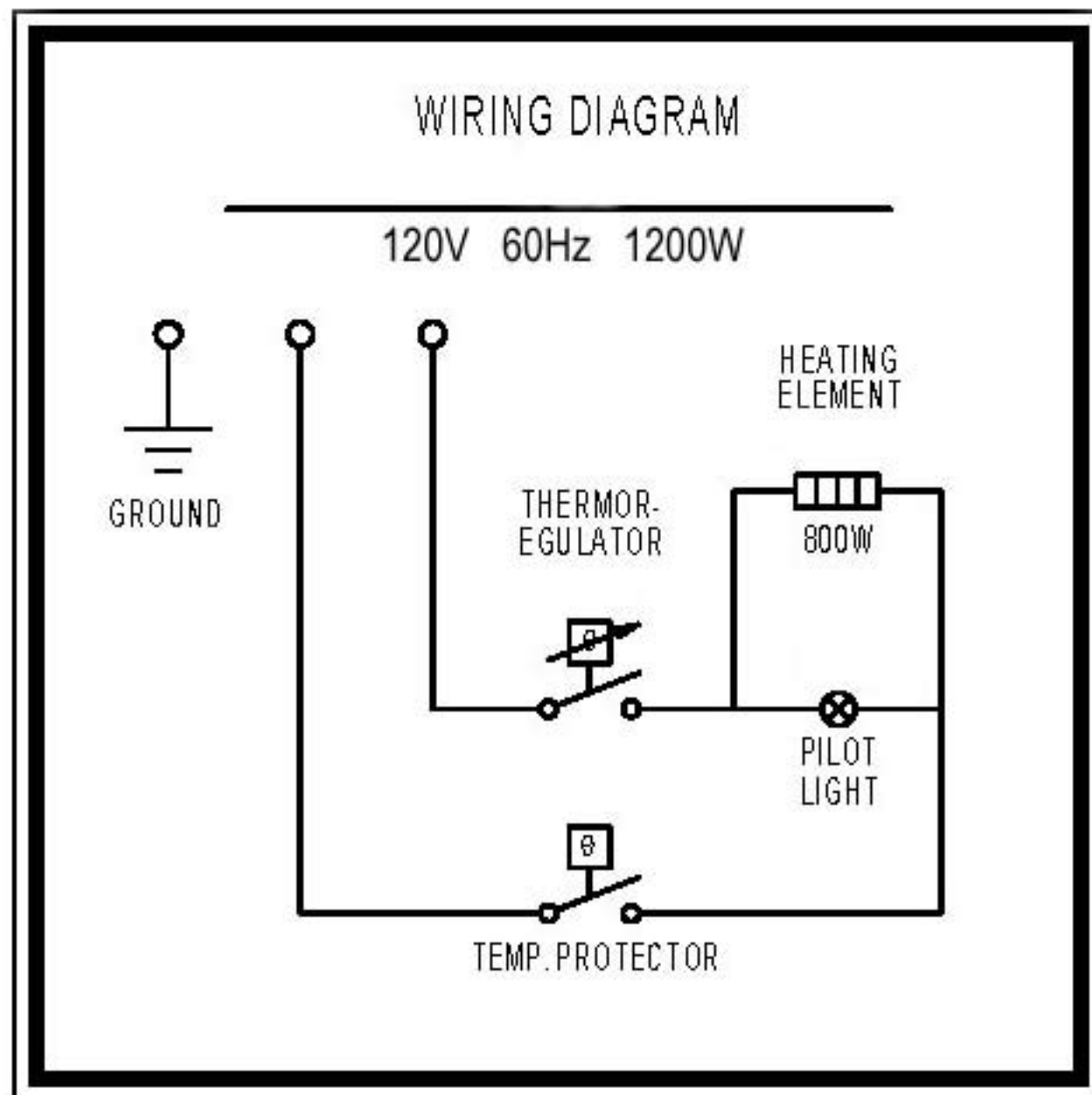

FW-1200WR

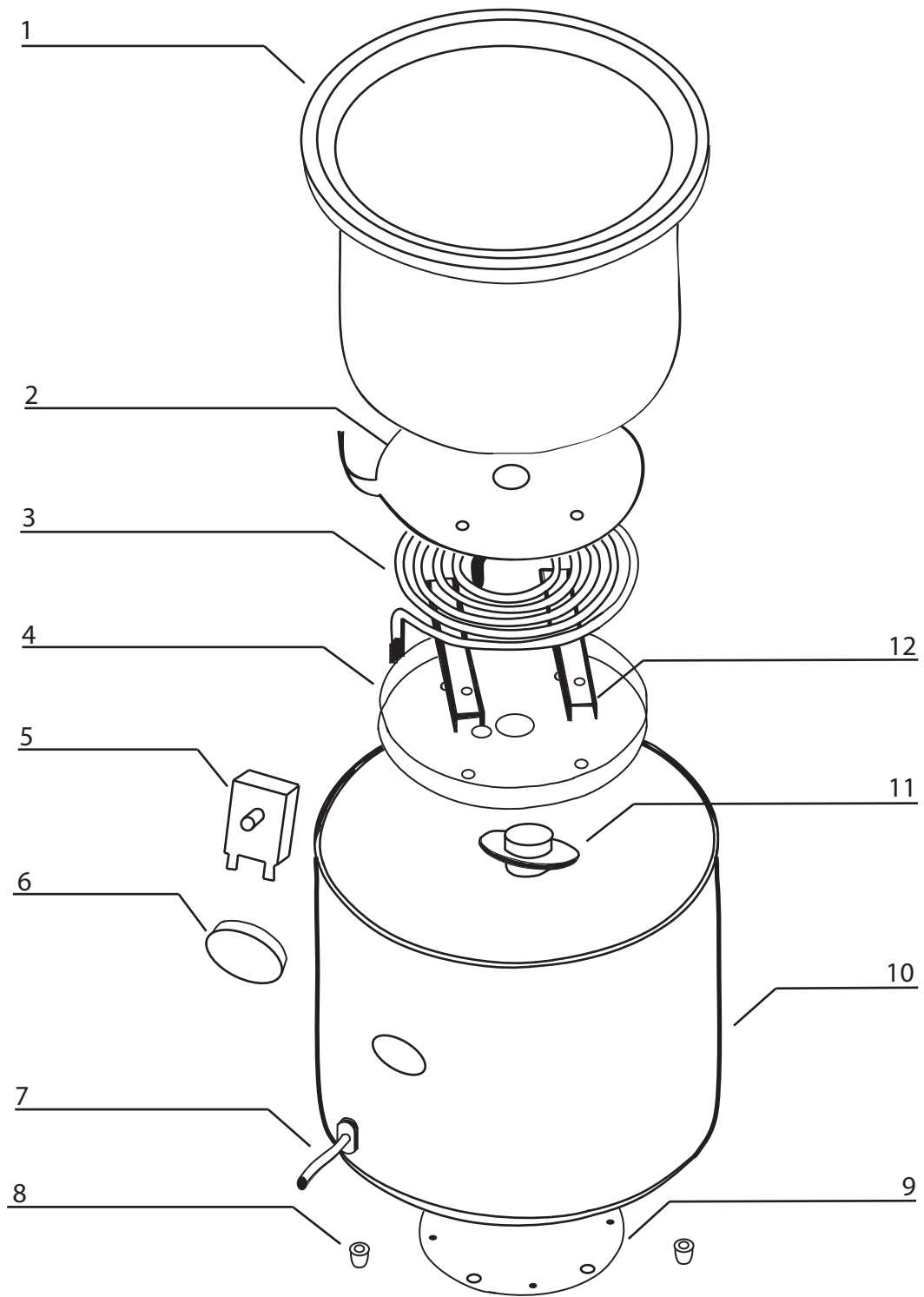

Round Food Warmer/Cooker - FW-1200WR

Reference Number	Part Number	Description
1		Soup Well
2		Heating Element Bolster
3	FWR-3	Heating Element
4		Heating Element Backing Plate
5	FWR-5	Thermostat
6	FWR-6	Switch
7	FWR-7	Power Cord and Strain Relief
8	FWR-8	Foot
9		Bottom Plate
10		Shell
11	FWR-11	Limiting Thermostat
12		Heating Element Fixer

VER811

ACE Equipment One Year Limited Warranty

Admiral Craft Equipment Corp. (ACE) warrants its equipment against defects in materials and workmanship, subject to the following conditions:

ACE Equipment is warranted for one year, effective from the date of purchase by the original owner. A copy of the original receipt or other proof of purchase is required to obtain warranty coverage. This warranty applies to the original owner only, and is not assignable.

Should any product fail to function in its intended manner under normal use within the limits defined in this warranty, at ACE's discretion, such product will be repaired, replaced with a refurbished unit, or replaced with a new unit by ACE, after defective unit has been inspected and defect has been confirmed. ACE does not assume any liability for extended delays in replacing any item beyond its control. This warranty does not apply to rubber and non-metallic synthetic parts that may need to be replaced due to normal usage, wear or lack of preventative maintenance.

This warranty covers products shipped into the 48 contiguous United States, Hawaii, and metropolitan areas of Alaska and Canada. Warranty coverage on products used outside the 48 contiguous United States, Hawaii and metropolitan areas of Alaska and Canada may vary. Contact ACE for details at 1-800-223-7750

The following conditions are not covered by warranty:

- Equipment failure relating to improper installation, improper utility connection or supply and problems due to improper ventilation.
- Equipment that has not properly been maintained, damage from improper cleaning, and water damage to controls.
- Equipment that has not been used in an appropriate manner, or has been subject to misuse, neglect, abuse, accident, alteration, negligence, damage during transit, delivery or installation, fire, flood, riot, or act of God.
- Equipment that has the model number or serial number removed or altered.
- Equipment on which the security seal has been broken.

If the equipment has been changed, altered, modified, or repaired without express written permission from ACE, then the manufacturer shall not be liable for any damages to any person or to any property, which may result from the use of this equipment thereafter.

This equipment is intended for commercial use only and this warranty is void if equipment is used in other than a commercial application.

For warranty and non-warranty related issues, technical support, purchase replacement parts and warranty registration visit www.admiralcraft.com. Please have your model number, serial number and proof of purchase ready. It is not necessary to contact the place where you originally purchased your product from.

“THE FOREGOING WARRANTY IS IN LIEU OF ANY AND ALL WARRANTIES EXPRESSED OR IMPLIED INCLUDING ANY IMPLIED WARRANTY OF MERCHANTABILITY OR FITNESS FOR PARTICULAR PURPOSES AND CONSTITUTES THE ENTIRE LIABILITY OF ACE. IN NO EVENT DOES THE LIMITED WARRANTY EXTEND BEYOND THE TERMS STATED HEREIN.”