



SPRING MOUNTS (Type "X-100" Series 1" Deflection)

Type "X-100" series Spring Mounts with one inch deflection solve troublesome vibration problems. These mounts are preferred over most rubber mounts due to the greater static deflection of the spring. "X-100" series spring mounts are designed for noise and vibration control applications in critical areas on concrete and wooden floors.



XE – 100 (Bolt Top)



XF – 100 (Flat Top)



XP – 1 (Pin Top)



XN-100 (Neoprene Top)

Above products are standard in BLUE, but can also be available in red (custom order)

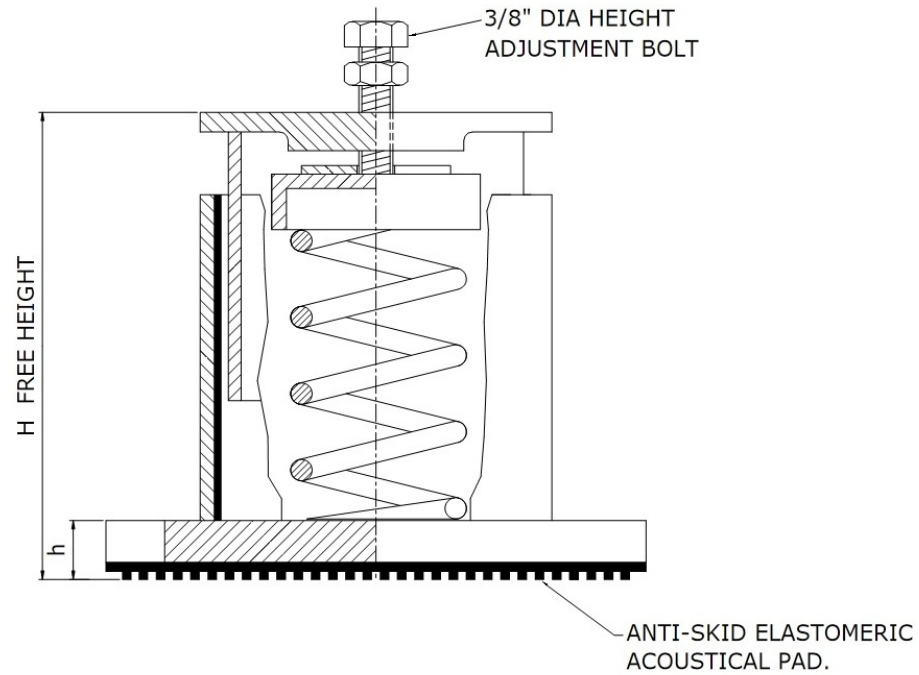
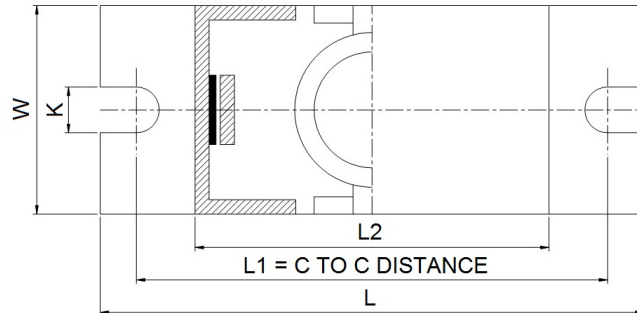

* Note that the above drawing is with XE – 100 Setup

MODEL	ADJUSTMENT	DIMENSION IN INCHES						
		L	L1	L2	W	K	H	h
XE (BOLT TOP)	EXTERNAL	5-5/8	5-1/8	4-1/4	2-1/4	3/8	4	1/2
XP (PIN TOP)	INTERNAL	5-5/8	5-1/8	4-1/4	2-1/4	3/8	4-1/4	1/2
XF (FLAT TOP)	INTERNAL	5-5/8	5-1/8	4-1/4	2-1/4	3/8	4-1/4	1/2
XN (NEOPRENE TOP)	INTERNAL	5-5/8	5-1/4	4-1/4	2-1/4	3/8	4-1/2	1/2



FEATURES:

The X-100 features a two piece cast iron housing for the spring. The mounts are provided with slotted mounting holes with a non-skid elastomeric acoustic pad on the base for ease in bolting to the floor. Resilient elastomeric snubbers on the inner panels prevent metal to metal contact and allow the springs to function properly. The X-100 spring mounts have a built-in leveling device (external or internal). These spring mounts can also be supplied with flat or non-skid neoprene top surface in case of internal level adjustment.

APPLICATION:

Used for air conditioning equipment such as compressors, air handling units, centrifugal fans, pumps, chillers and similar applications.

NOTE:

Adjust mounting so that the upper housing clears the lower housing by at least 1/4" but not more than 1/2".

x = (Model Types E, P, F, N see above)

ISOLATOR MODEL	RATED LOAD (LBS)	RATED DEFLECTION (INCH)	COLOR	
			MAIN	STRIPE
Xx-101	60	1.3	SILVER	BLUE
Xx-102	100	1.3	SILVER	ORANGE
Xx-103	165	1.2	SILVER	BROWN
Xx-104	260	1.0	SILVER	BLACK
Xx-105	370	0.8	SILVER	YELLOW
Xx-106	450	0.5	SILVER	RED
Xx-107	700	0.45	SILVER	GREEN