

## USER SERVICING INSTRUCTIONS



- DO NOT allow water or steam to get on or into the fan motor housing.
- DO NOT use gasoline, thinner or benzene on or near the fan.
- It is recommended to periodically clean this unit. To clean unit, lightly run a vacuum cleaner nozzle over the fan grill to remove any dust or dirt that may have accumulated inside or on the unit.
- Wipe all parts with a soft cloth. Soft cloth may be moistened with a mild soap solution.
- Dry all parts completely before reassembling or re-connecting the fan to the wall outlet.
- Keep surfaces dry and clean for a longer lasting finish.
- All repairs must be done by authorized technician.
- Do not modify equipment or power cord, Warranty will be voided.



# 36" & 42" Tilting Belt Drive Drum Fan Instruction Manual

Model 246558 & Model 246559

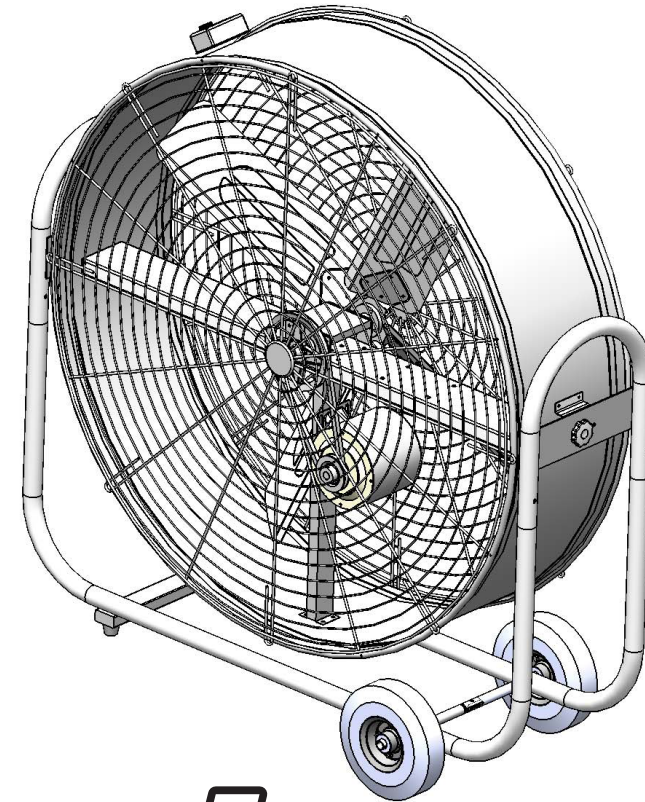

# READ & SAVE THESE INSTRUCTIONS

Thank you for purchasing a Fan from Global Industrial. **Please Read These Instructions Carefully Before Operation.**

Please note that the actual appearance of the product purchased is subject to change and may vary from the illustrations in this instructions manual due to continuous product upgrades. Although there may be slight differences between the actual product and the illustrated version, it will not in any way affect the performance of the product you purchased.

## TECHNICAL SPECIFICATION

	Model 246558	Model 246559
Fan Diameter	36"	42"
Max Airflow (CFM)	10,500/9,800	13,400/12,500
Power Supply / Frequency	120V/60Hz	120V/60Hz
AMPs	4.07	5.41
Dimension (W" x D" x H")	42 x 14 <sup>1</sup> / <sub>2</sub> x 42 <sup>1</sup> / <sub>2</sub>	48 x 14 <sup>1</sup> / <sub>2</sub> x 49 <sup>1</sup> / <sub>2</sub>

## ⚠ WARNING ⚠

- To reduce the risk of fire or electrical shock, do not expose to water or rain.
- To reduce the risk of fire or electrical shock, do not use fan with a solid state speed control device.
- To prevent risk of injury or electrical shock, do not touch fan when hands are wet.
- Unplug fan before moving or transporting fan.
- Unplug fan before cleaning or performing maintenance.
- Any modification to fan will void warranty.
- Unplug fan when not in use. Unplug fan by holding the plug. To reduce injury and prevent breakage, do not unplug by holding the cord.
- DO NOT use fan if power cord or plug is broken.
- DO NOT use fan with an extension cord.
- DO NOT use fan near fire or water.
- DO NOT use outdoors. For indoor use only.
- DO NOT insert hands into the guard or near moveable parts.
- Make sure front and rear guards are screwed in place and secured in locking position before operation.

## WHEEL ASSEMBLY

1. Insert the wheel axel into the frame and align hole A with pop-up button B. Insert until pop-up button B pops-up through hole A and secures wheel in place. Repeat process for other side.

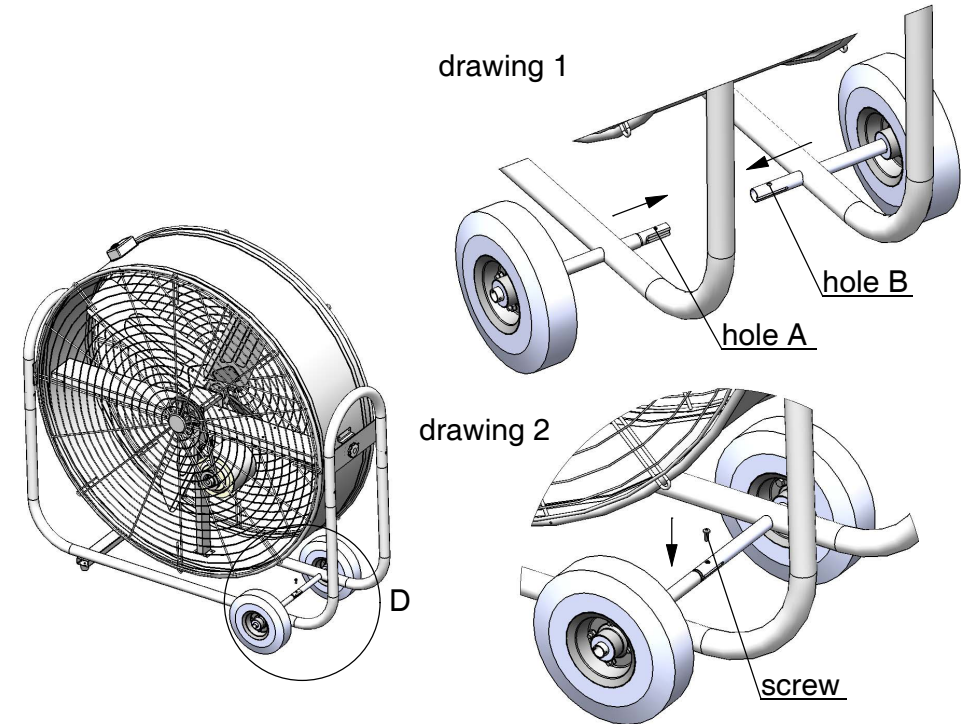

## OPERATING INSTRUCTIONS

1. **AIRFLOW:** To adjust airflow upward or downward, simply tilt fan head to the desired angle.
2. **SPEED CONTROL:** This 2-speed fan utilizes a rotary control switch for speed control. (0 = Stop, 1 = Low, 2 = High)  
**Note: Low Voltage less than 110V or High Voltage greater than 120V may cause damage to motor.**