

235 Series

Mechanical

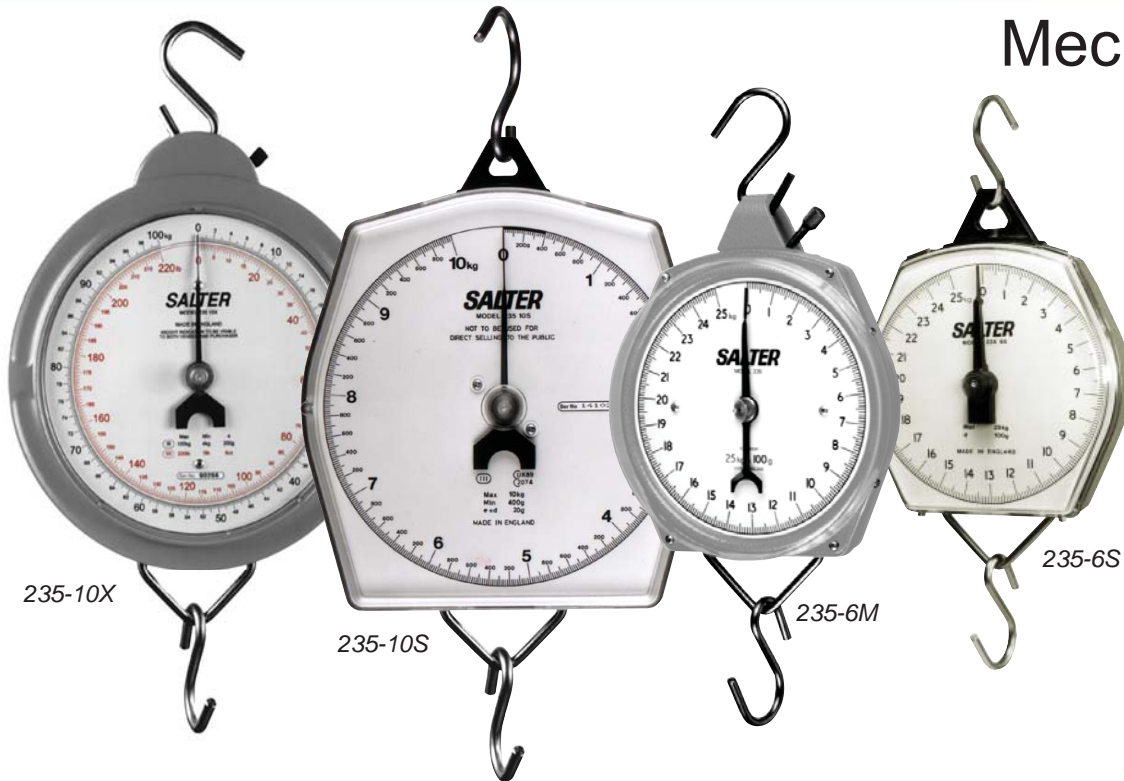

- Robust
- Accurate
- Reliable
- Portable
- Dual Markings Available for Metric and Avoirdupois

- Low Cost
- Easy-to-Read
- Corrosion Resistant
- Capacities- 1 kg / 11 lb to 300 kg / 660 lb

VALUE IN
WEIGHING



235 Series

Model 235-6S

Compact, robust and corrosion resistant, 150 mm / 6" diameter dial housed in a tough ABS plastic case with shatterproof polycarbonate dial cover. Low friction acetal bearings provide positive movement to give maximum sensitivity. Accurate to one part in 250 with up to 15% zero adjust. Supplied with top and bottom hooks.

Option: Oblong pan (5 kg / 11 lb only)

Single Marked

- 5 kg x 20 g
- 10 kg x 50 g
- 25 kg x 100 g
- 50 kg x 200 g
- 100 kg x 500 g

Dual Marked

- 5 kg x 20 g / 11 lb x 1 oz
- 10 kg x 50 g / 22 lb x 2 oz
- 25 kg x 100 g / 56 lb x 4 oz
- 50 kg x 200 g / 110 lb x 8 oz
- 100 kg x 500 g / 220 lb x 1 lb

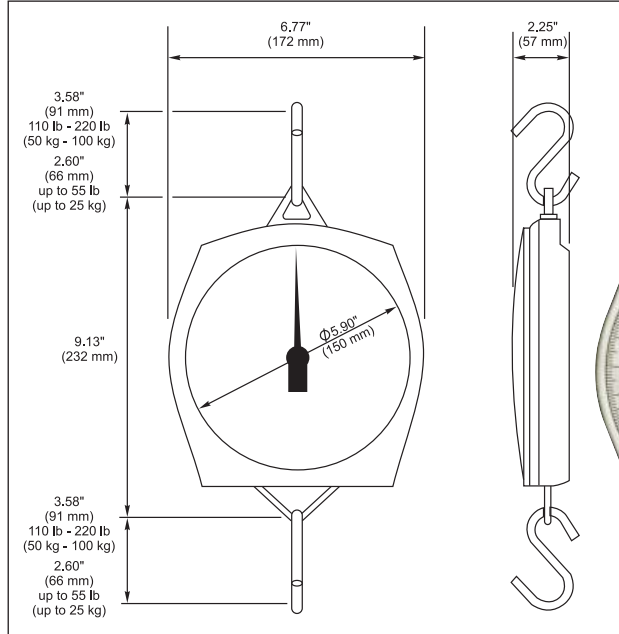

Model 235-6M

Compact, robust, 150 mm / 6" diameter dial housed in the traditional metal case. Accurate to one part in 250 with up to 10% zero adjustment. Supplied with top and bottom hooks.

Single Marked

- 1 kg x 5 g
- 2 kg x 10 g
- 5 kg x 20 g
- 10 kg x 50 g
- 25 kg x 100 g
- 50 kg x 200 g
- 100 kg x 500 g
- 200 kg x 1 kg

Dual Marked

- 5 kg x 20 g / 11 lb x 1 oz
- 10 kg x 50 g / 22 lb x 2 oz
- 25 kg x 100 g / 56 lb x 4 oz
- 100 kg x 500 g / 220 lb x 1 lb

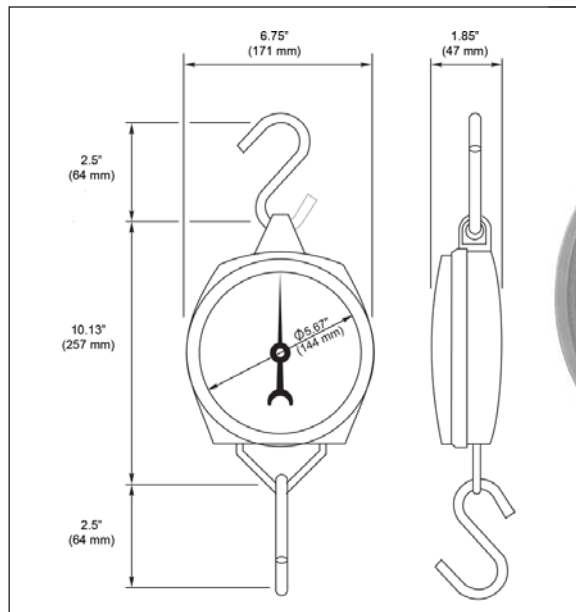

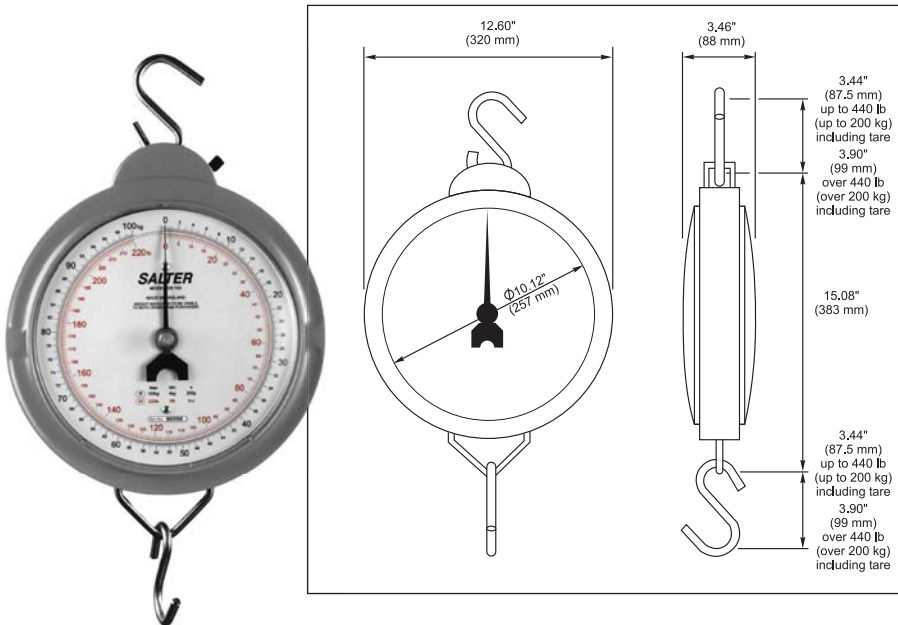

Model 235-10X

Heavy duty suspended scale. Easy to read dial housed in a robust die cast casing. Low friction bearings provides positive movement to give maximum sensitivity. Accurate to one part in 500 with up to 10% zero adjustment. Supplied with top and bottom hooks as standard.

Single Marked

- 100 kg x 200 g
- 200 kg x 500 g
- 300 kg x 1 kg

Dual Marked

- 200 kg x 500 g / 440 lb x 1 lb

With Double Lipped Scoop

- 5 kg x 10 g

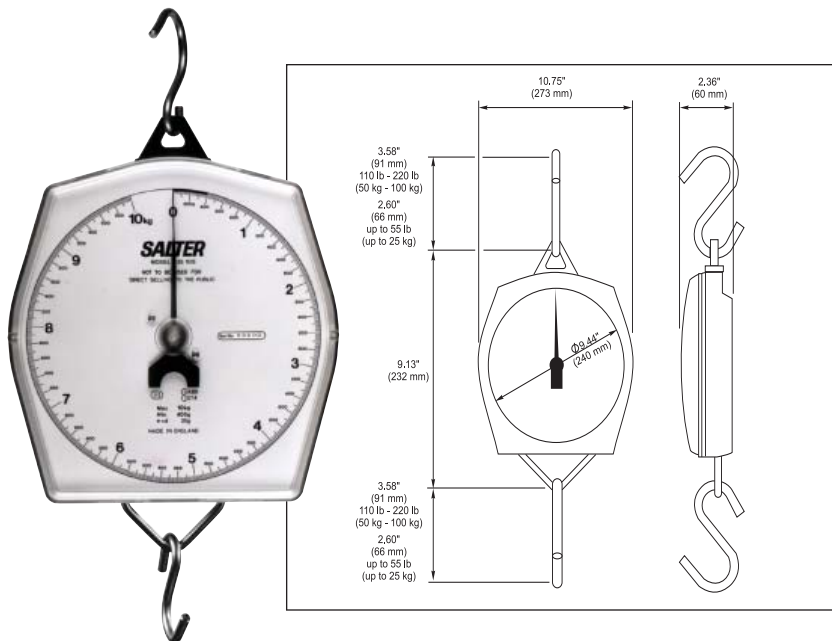

Model 235-10S

Robust and corrosion resistant, large easy to read 254 mm diameter dial housed in a tough ABS plastic case with a shatterproof polycarbonate dial cover. Low friction bearings provide positive movement to give maximum sensitivity. Accurate to one part in 500 with up to 15% zero adjust. Supplied with top and bottom hooks.

Option - Oblong pan (5 kg / 11 lb only)

Single Marked

- 5 kg x 10 g
- 10 kg x 20 g
- 25 kg x 50 g
- 50 kg x 100 g
- 100 kg x 200 g

Packaging Dimension:

- 370 mm (L) x 290 mm (W) x 80 mm (H)
- 14.5" L x 11" W x 3" H



a division of Avery Weigh-Tronix, LLC

Brecknell

1000 Armstrong Dr., Fairmont, MN 56031
Toll free: 800-637-0529, Tel: 507-238-8702
Fax: 507-238-8271
e-mail: sales@brecknellscales.com
www.brecknellscales.com



Brecknell

Foundry Lane, Smethwick
West Midlands B66 2LP UK
Tel: +44 (0) 845 246 6717
Fax: +44 (0) 845 246 6718
Email: sales@brecknellscales.co.uk
www.brecknellscales.co.uk

