

**www.ergotron.com**  
 USA 1-800-888-8458  
 Europe +31 (0)33-45 45 600  
 China 86-769-86018920

For service and warranty visit [www.ergotron.com](http://www.ergotron.com)  
 Si desea información de servicio y garantía, visite [www.ergotron.com](http://www.ergotron.com)  
 Pour toute question concernant la garantie ou le service client, consultez [www.ergotron.com](http://www.ergotron.com)  
 Weitere Informationen zu Service und Gewährleistung erhalten Sie unter [www.ergotron.com](http://www.ergotron.com)  
 Ga voor service en garantie naar [www.ergotron.com](http://www.ergotron.com)  
 Per assistenza e la garanzia visitare [www.ergotron.com](http://www.ergotron.com)  
 Gå in på [www.ergotron.com](http://www.ergotron.com) för service och garanti  
 サービスおよび保証について詳しくは、[www.ergotron.com](http://www.ergotron.com) をご覧ください。  
 有关服务和保修，请访问 [www.ergotron.com](http://www.ergotron.com)

### www.ergotron.com



User's Guide - English  
 Guía del usuario - Español  
 Manuel de l'utilisateur - Français  
 Gebruikersgids - Nederlands  
 Benutzerhandbuch - Deutsch  
 Guida per l'utente - Italiano  
 ユーザーガイド：日本語  
 用户指南：汉语

**Ergotron's Medical Grade Power Strip provides electrical AC power outlets for mobile point of care computing equipment in a healthcare environment.**



#### Outlet Protector

(individual flip-hatch for each outlet)

1x

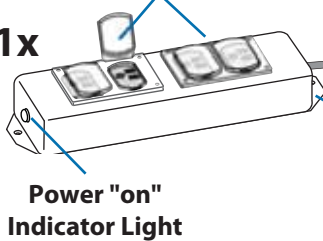

3' - 4' (91-122 cm) power cord\*

Circuit Breaker Reset Button

Polarized Connector

2x  
M4 x 8mm

1x

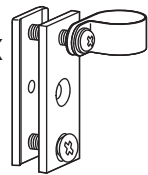

2x

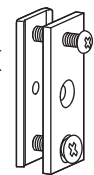

3x



1x

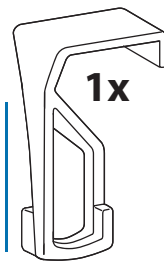

\*To obtain 6' (183 cm) of usable length, pre stretch cord to 7' (213 cm). This may require up to 25 lbs (11.34 kg) of force.

#### Mount to Rear of Cart

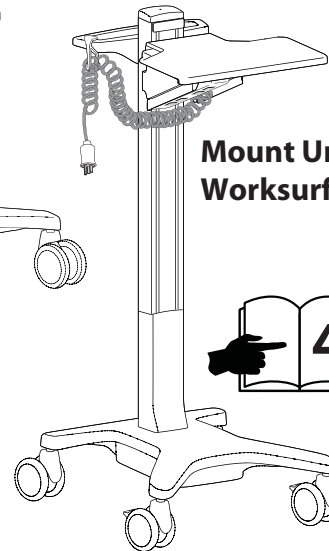
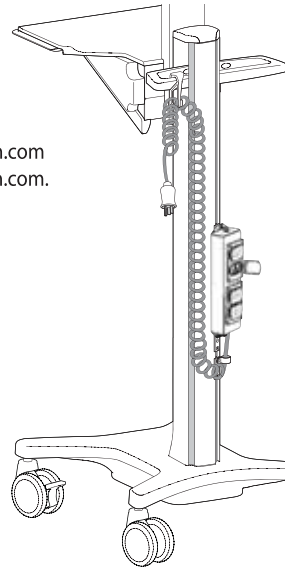

#### Mount Under Worksurface

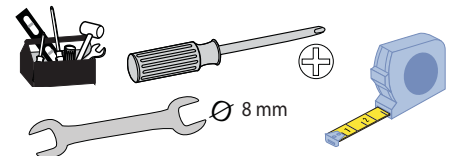

#### See Special Instructions on Page 4



Ø 1/4" (6.35 mm)  
Drill for Steel

**Medical Grade Power Strip** - Input: 120VAC/60 Hz; Output: 120VAC/60 Hz, 15 A maximum, total.

Ergotron's Medical Grade Power Strip includes 4 power outlets with individual protectors, power indicator light, 2 circuit breakers, a coiled cord with strain relief and storage hook, and a polarized connector designed for use in Hospital Grade Receptacles.

- The Medical Grade Power Strip is certified to UL 1363A.
- The recommended storage temperature is 15°C (59°F). The minimum storage temperature is -20°C (-4°F) and the maximum storage temperature is 60°C (104°F). The recommended humidity range for storage is 0-95% rH. Refer to pages 6-7 for Maintenance and Safety information.

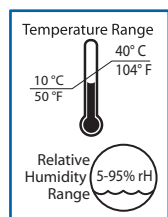

Operational

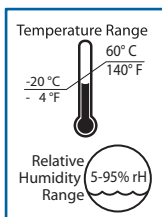

Storage

#### FCC Compliance Statement

Ergotron's Medical Grade Power Strip has been tested and found to comply with the limits for a Class A digital device, pursuant to part 15 of the FCC Rules. These limits are designed to provide reasonable protection against harmful interference when the equipment is operated in a commercial environment. This equipment generates, uses, and can radiate radio frequency energy and, if not installed and used in accordance with the instruction manual, may cause harmful interference to radio communications. Operation of this equipment in a residential area is likely to cause harmful interference in which case the user will be required to correct the interference at his own expense.

**Changes or modifications not expressly approved by Ergotron, Inc. could void the user's authority to operate the equipment.**  
 Please contact Ergotron for complete EMC compatibility information.

# 1 Mount to Rear of Cart

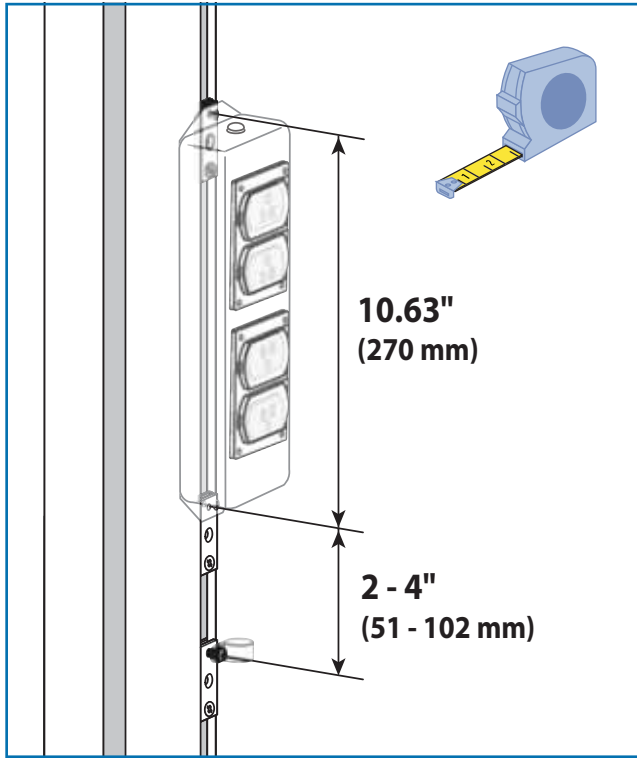

**C** Lift riser to highest position.

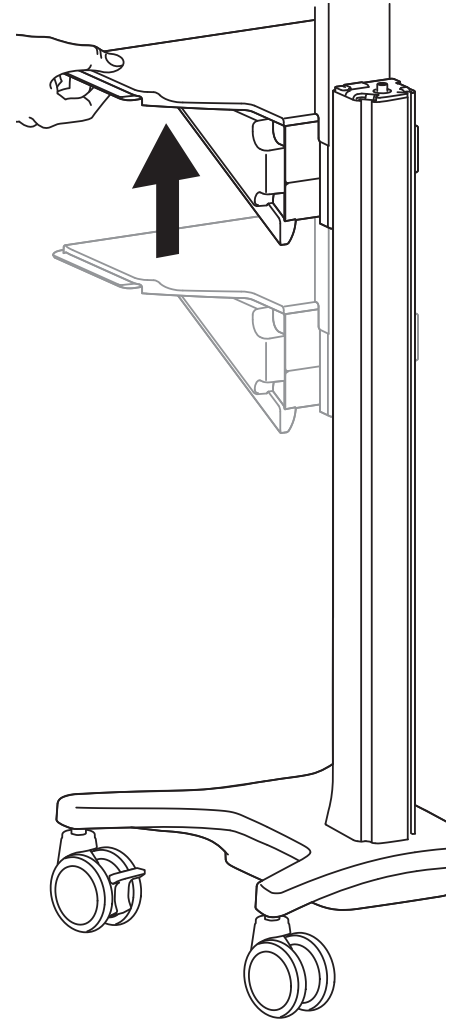

**a**

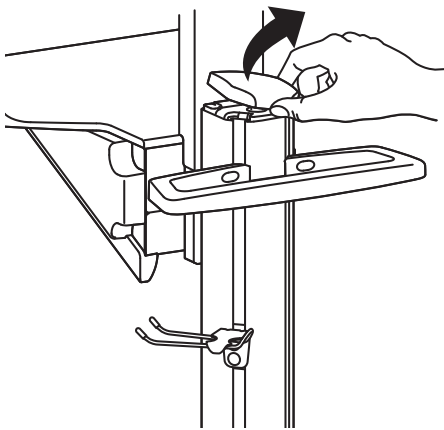

**b**

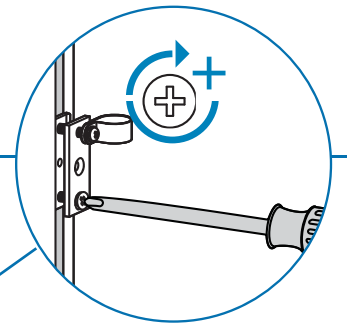
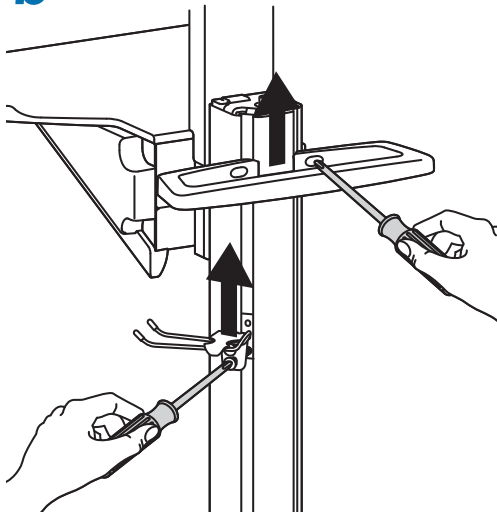

# 2 a

1x

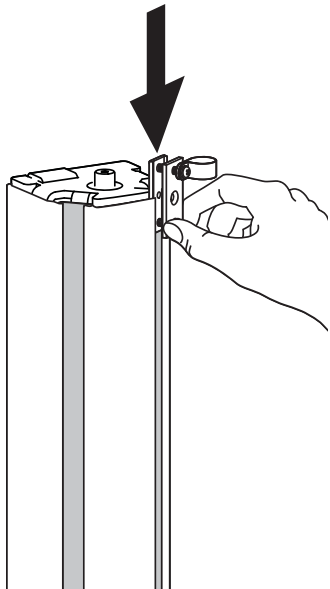
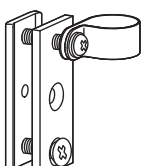

**b**

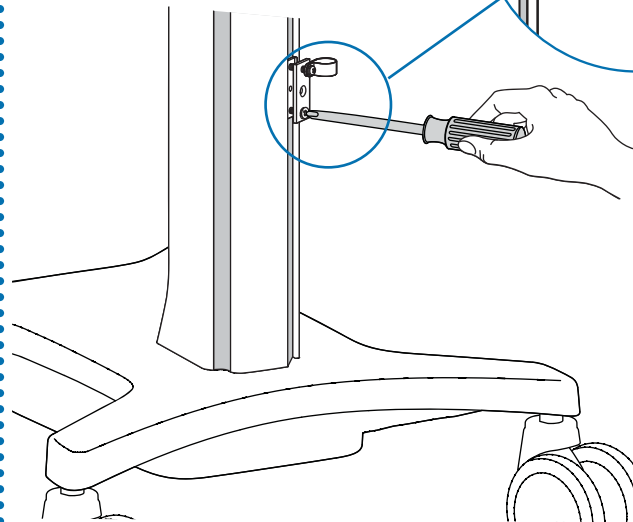

c

2x

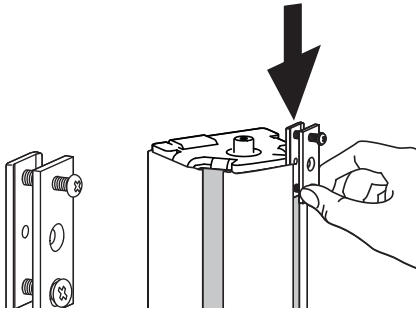

d

2x

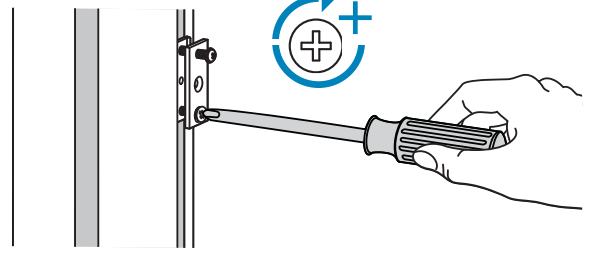

3 a

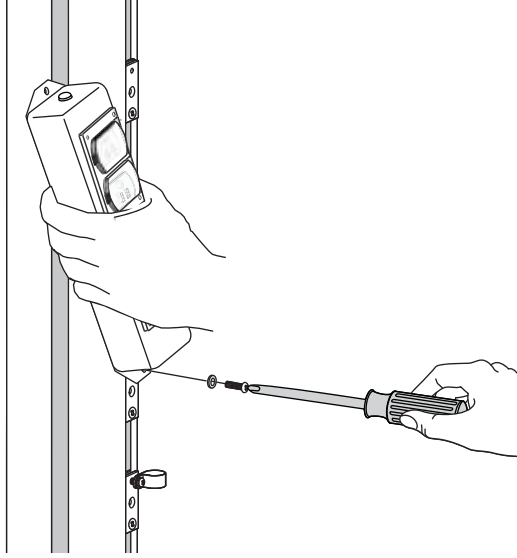

b

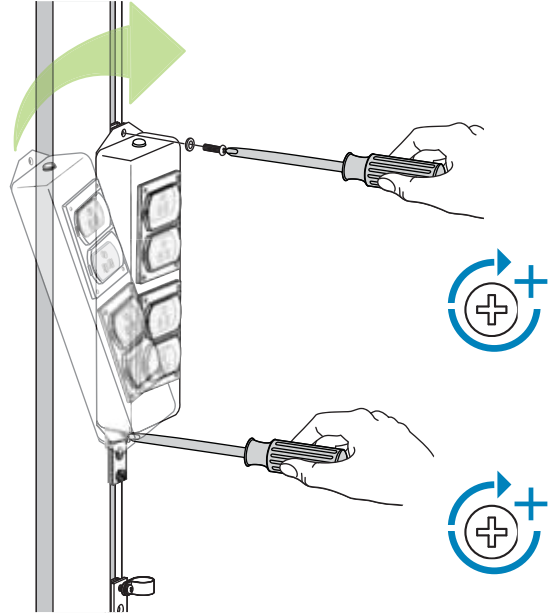

4 a

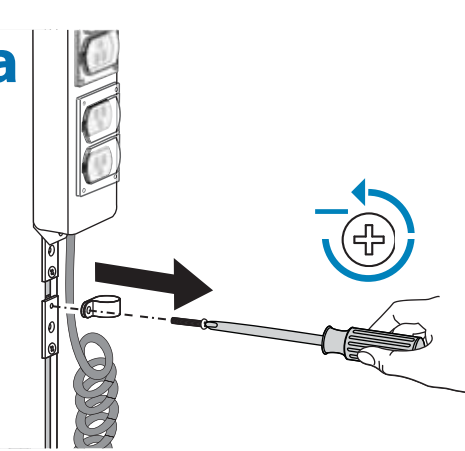

b

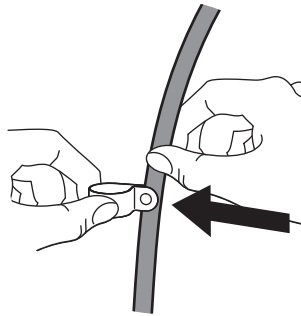

c

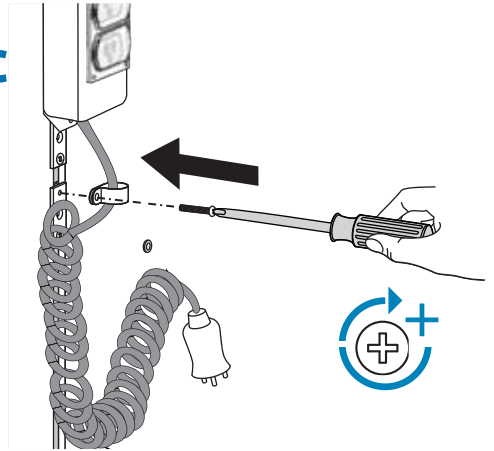

d

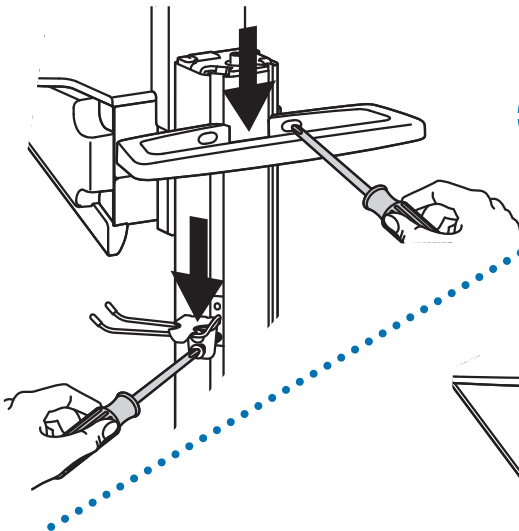

e

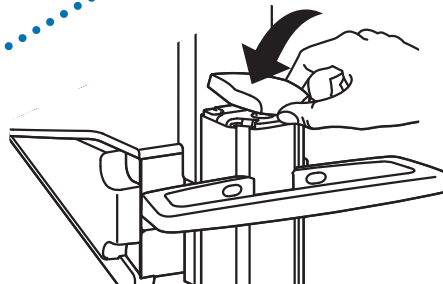

5



# Mount Under Worksurface

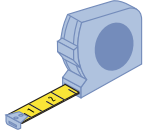
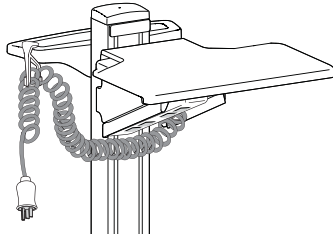

Mounting Hole spacing = 10.63" (270 mm)

**Worksurfaces with pre-drilled mounting holes:** skip steps 1-2, proceed to mounting instruction steps 3-5.

**Worksurfaces with out pre-drilled mounting holes:** follow steps 1-2 then proceed to mounting instruction steps 3-5.

1

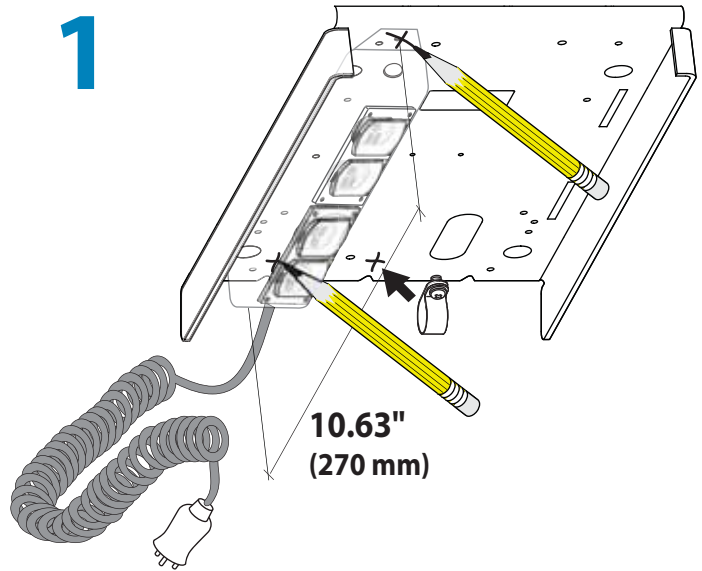

2 a

Drill for Steel  
Ø 1/4" (6.35 mm)

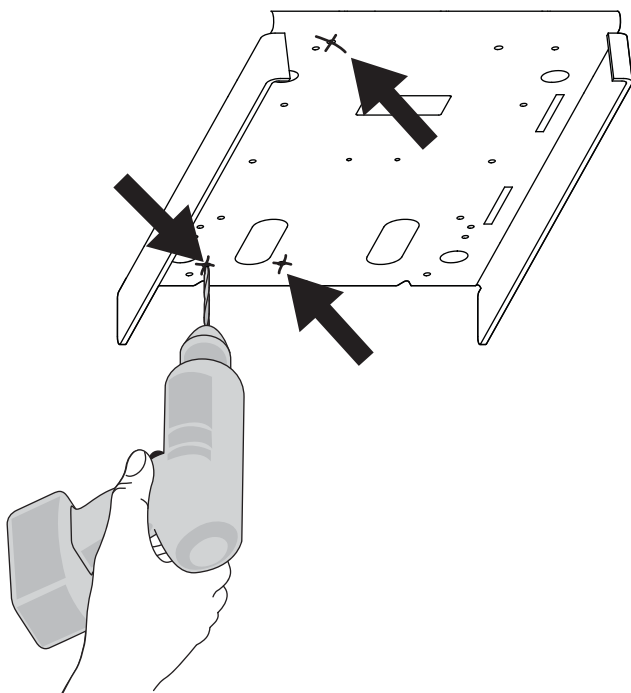
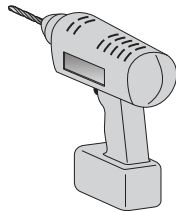

b

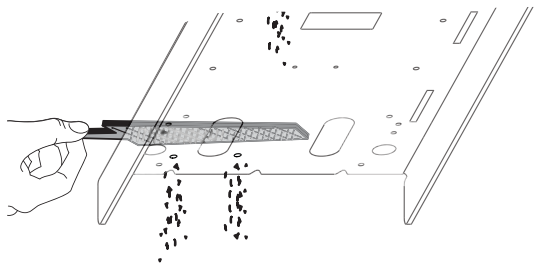

c

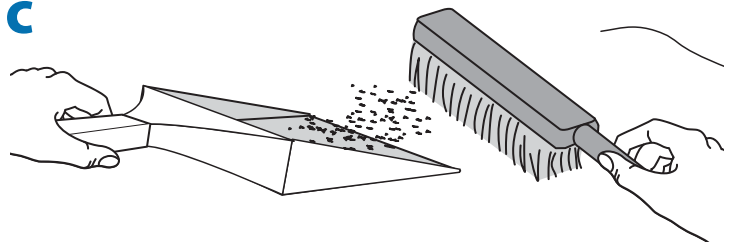

3 a

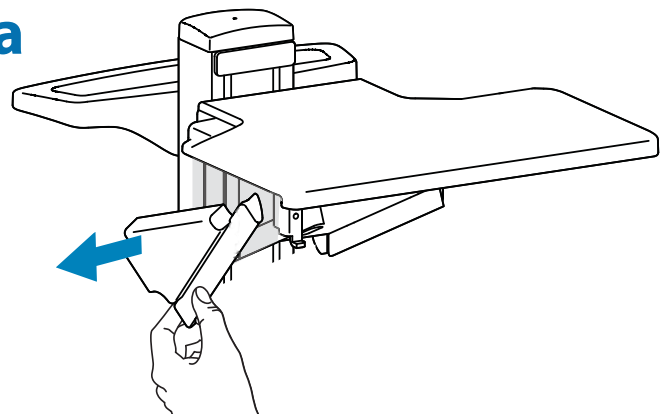

**3 b**

2x

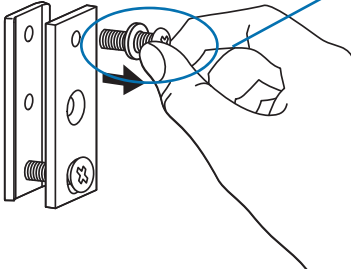
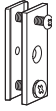

**c**

2x

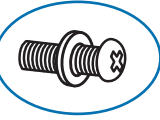

2x

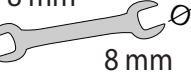

8 mm

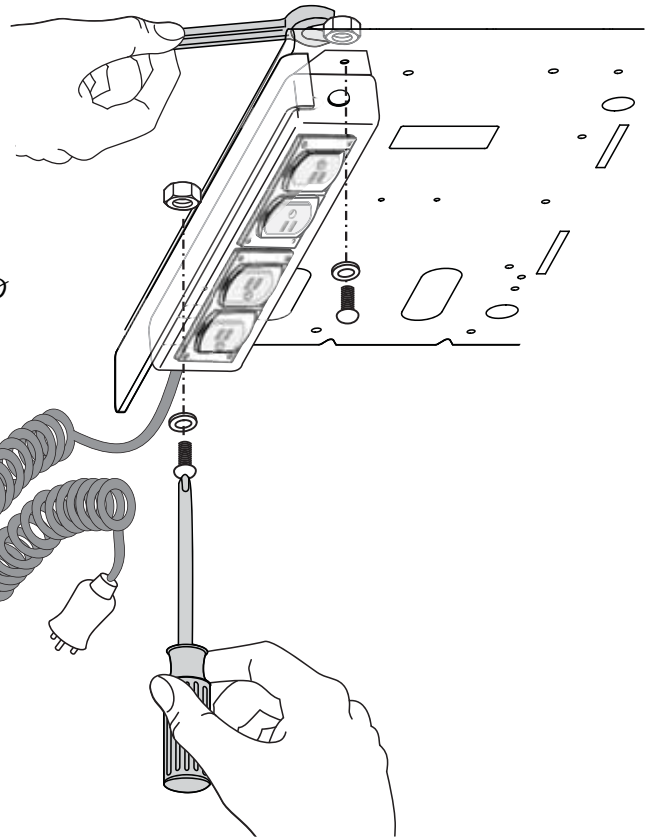
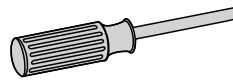

**4 a**

1x

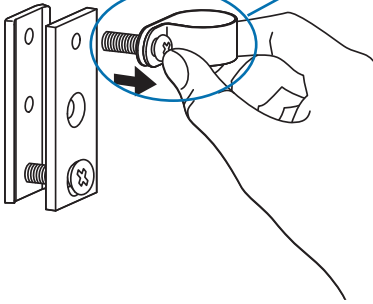
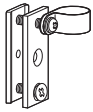

**b**

1x

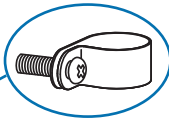

Cable Routing:  
Strain-Relief

1x



8 mm



ø 8 mm

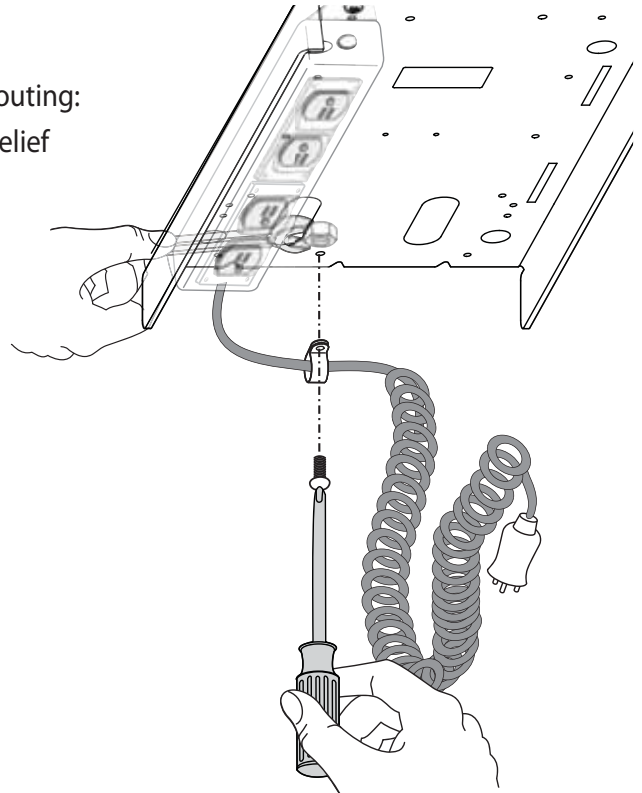
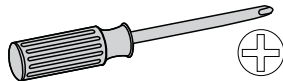

**c**

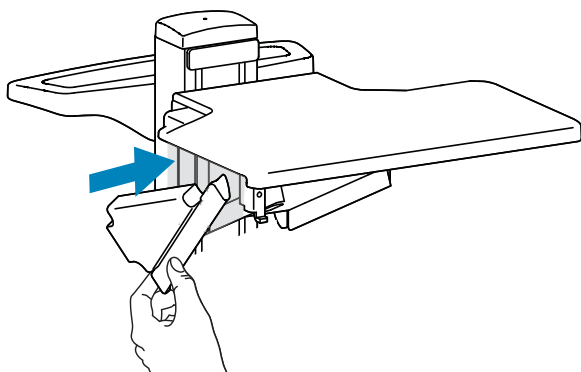

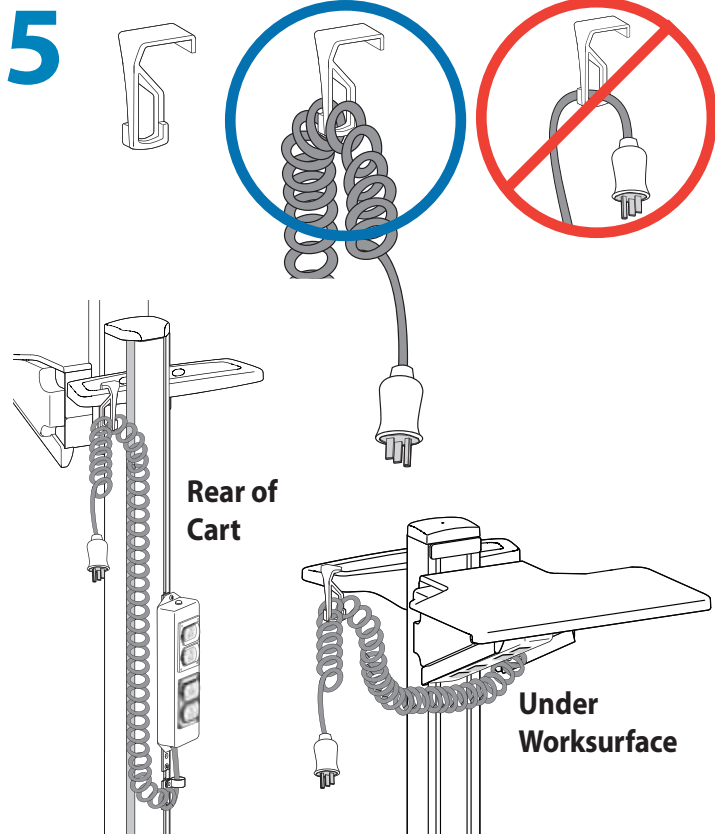

**6** Connect user equipment to power strip outlets; observe 15A maximum load rating. If the 15A limit is exceeded, the circuit breaker will trip.

**To Re-set Circuit Breakers:**

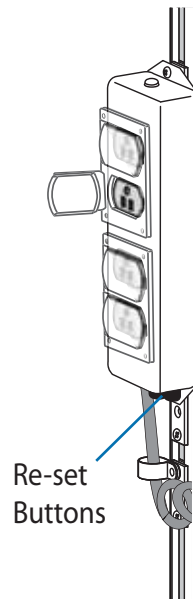

**a** Unplug all user cables from power strip. Check that the total load does not exceed the 15A maximum load rating. Provide alternative connection point for excess load.

**b** Reset circuit breakers by pushing-in buttons—breakers will click and buttons will stay depressed.

**c** Reconnect user power cables (observing 15A maximum load rating).

**d** If unit does not function after following above steps, contact Ergotron Customer Care.

**Maintenance & Safety**

**Hazard Symbols Review**

The Meaning of Symbols appearing in this Guide, on the Medical Grade Power Strip. These symbols alert you to a safety condition that demands your attention. You should be able to recognize and understand the significance of the following Safety Hazards if you encounter them on the Cart or within Cart documentation such as this Set-up Guide.

**Safety Alerts Associated with this Product**

The following Warnings/Cautions appear in this reference guide or on the Power Strip. NOTE: Failure to adhere to these guidelines may result in equipment damage or personal injury.

**⚠ Cleaning and Maintenance**

The following procedures are not guaranteed to control infection. The hospital infection control administrator or epidemiologist should be consulted regarding cleaning procedures and processes.

**⚡** To avoid risk of electric shock, do not expose electrical components to water, cleaning solutions or other potentially corrosive liquids or substances.

**⚠** Do not immerse Power Strip or Power Strip components in liquid or allow liquids to flow into the Power Strip. Wipe all cleaners off surface immediately using a damp cloth. Thoroughly dry surface after cleaning.

**⚡** Do not use flammable cleaners on Power Strip surfaces due to close proximity of electrical power and equipment.

All paints and plastic Power Strip components will withstand cleaning by most commonly used, diluted, non-abrasive solutions such as quaternary ammonia compounds, ammonia enzyme cleaners, bleach or alcohol solutions.

- Pen and permanent and dry erase markers can be removed with 91% isopropyl alcohol and a soft cloth.

- Iodine stains can be removed with commonly used cleaners and a soft cloth.

- Never use steel wool or other abrasive materials that will damage the surface finish.

It is recommended that any cleaning solution be tested on a small, inconspicuous area to ensure surface is not harmed.

**⚠** Adjustment, Service, Replacement - DO NOT attempt to adjust, service or replace any part of the Power Strip unless directed to do so through Ergotron-approved documentation (i.e. installation instructions). Only Ergotron, Inc. or an Ergotron-certified entity may adjust, service or replace Power Strip components. If any component on the Power Strip is missing or damaged, the Power Strip must not be used, contact Ergotron Customer Care immediately to request a replacement part.

**⚠** Cables - Keep cables neatly organized (the provided Strain Relief and Hook are designed for this purpose). Excess cables should be routed away from moving components with cable clips or ties. Review Cable Routing section of this guide, or contact Ergotron Customer Care for more information.

**⚠** Customer Equipment- Do not connect electrical equipment beyond rated ....

**⚠** Customer Equipment- Only cart-mounted electrical equipment should be connected to Power Strip.

**⚠** The polarized cord on this Power Strip is Hospital Grade Only. Grounding reliability can only be achieved when the equipment is connected to an equivalent receptacle marked "Hospital Only" or "Hospital Grade".

**⚠** The device is not suitable for use in the presence of a flammable anaesthetic mixture with air or with oxygen or nitrous oxide.

Color	Symbol	Signal Word	Level of Hazard
Red		<b>DANGER</b>	Indicates an imminently hazardous situation which, if not avoided, will result in death or serious injury.
Orange		<b>WARNING</b>	Indicates a potentially hazardous situation which, if not avoided, could result in death or serious injury.
Yellow		<b>CAUTION</b>	Indicates a potentially hazardous situation which, if not avoided, may result in minor or moderate injury.
None		<b>CAUTION</b>	Used without the safety alert symbol indicates a potentially hazardous situation which, if not avoided, may result in property damage.
Red, Orange or Yellow		<b>Electrical</b>	Indicates an impending electrical hazard which, if not avoided, may result in personal injury, fire and/or death.



## **DANGER!**

**ELECTRICAL CORDS CAN BE HAZARDOUS**  
 Misuse Can Result in FIRE or DEATH by ELECTRICAL SHOCK.  
 Please Read and Follow Product Manual Instructions.  
**THIS IS A POLARIZED CORD - HOSPITAL GRADE ONLY**  
 NOTE: Grounding Reliability Can Only Be Achieved When  
 the Equipment Is Connected To An Equivalent Receptacle Marked  
 "HOSPITAL ONLY" Or "HOSPITAL GRADE"



### DO NOT REMOVE THIS LABEL!

- Inspect Cord Thoroughly Before Each Use. DO NOT USE IF DAMAGED.
- Do Not Plug More Than SPECIFIED NUMBER OF WATTS Into Power System.
- Do Not Run Cord Through Doorways, Holes in Ceilings, Walls or Floors.
- FULLY INSERT Plug Into Outlet.
- Do Not Remove, Bend or Modify Any Metal Prongs or Pins of Cord.
- Do Not Use Excessive Force to Make Connections.
- Keep Away From Water. DO NOT USE WHEN WET.
- Keep Children Away From Cord.
- Do Not Plug Cord into An Extension Cord.
- AVOID OVERHEATING. Uncoil Cord and Do Not Cover It With Any Material.
- Do Not Drive, Drag or Place Objects Over Cord. Do Not Walk On Cord.
- GRASP PLUG to REMOVE FROM Outlet. Do Not Unplug By Pulling On Cord.

820-672

### Recommended Periodic Inspection and Maintenance

- Inspect Cord Thoroughly Before Each Use. DO NOT USE IF DAMAGED.
- Do Not Plug More Than SPECIFIED NUMBER OF WATTS Into Power System.
- Do Not Run Cord Through Doorways, Holes in Ceilings, Walls or Floors.
- FULLY INSERT Plug Into Outlet.
- Do Not Remove, Bend or Modify Any Metal Prongs or Pins of Cord.
- Do Not Use Excessive Force to Make Connections.
- Keep Away From Water. DO NOT USE WHEN WET.
- Keep Children Away From Cord.
- Do Not Plug Cord into An Extension Cord.
- AVOID OVERHEATING. Uncoil Cord and Do Not Cover It With Any Material.
- Do Not Drive, Drag or Place Objects Over Cord. Do Not Walk On Cord.
- GRASP PLUG to REMOVE FROM Outlet. Do Not Unplug By Pulling On Cord.

Polarized Connector	Inspect for damage.	Weekly	Any user.
Power Outlets	Inspect for damage or dirt.	Weekly	Any user.
Circuit Breakers	Test Circuit Breakers.	Weekly	IT Personnel
Coiled Cord	Inspect for wear, damage, or stretching. Move attachment hook to avoid dragging on floor	Weekly	Any user

### Power Strip Internal & External Components Disposal

1. Internal wiring, power cord and all electrical components should be recycled through an electronics recycler.
2. Remaining plastics and metals can be recycled through a commercial recycler.

Guidance and Manufacturer's Declaration – Electromagnetic Emissions		
Ergotron's Medical Grade Power Strip is intended for use in the electromagnetic environment specified below. The customer or the user of the Medical Grade Power Strip should assure that it is used in such an environment.		
Emissions Test	Compliance	Electromagnetic environment – guidance
RF Emissions CISPR 11	Group 1	Ergotron's Medical Grade Power Strip does not use RF energy for its internal function. Therefore, its RF emissions are very low and unlikely to cause any interference in nearby electronic equipment.
RF Emissions CISPR 11	Class B	Ergotron's Medical Grade Power Strip is suitable for use in all establishments other than domestic and those directly connected to the public low-voltage power supply network that supplies buildings used for domestic purposes.
Harmonic Emissions IEC 61000-3-2	Class B	
Voltage fluctuations/ flicker emissions IEC 61000-3-3	Complies	

Guidance and Manufacturer's Declaration – Electromagnetic Immunity			
Ergotron's Medical Grade Power Strip is intended for use in the electromagnetic environment specified below. The customer or the user of the Medical Grade Power Strip should assure that it is used in such an environment.			
Immunity Test	IEC 60601 Test Level	Compliance Level	Electromagnetic environment – guidance
Electrostatic Discharge (ESD) IEC 61000-4-2	±6 kV contact ±8 kV air	Complies	Floors should be wood, concrete, or ceramic tile. If floors are covered with synthetic material, the relative humidity should be at least 30%
Electrical Fast Transient/Burst IEC 61000-4-3	±2 kV for power supply lines ±1 kV for input/output lines	Complies	Mains power quality should be that of a typical commercial or hospital environment.
Surge IEC 61000-4-5	±1 kV differential mode ±2 kV common mode	Complies	Mains power quality should be that of a typical commercial or hospital environment
Voltage Dips, short interruptions, and voltage variations on power supply input lines IEC 61000-4-11	<5% U <sub>T</sub> (>95% dip in U <sub>T</sub> ) for 0.5 cycle 40% U <sub>T</sub> (60% dip in U <sub>T</sub> ) for 5 cycles 70% U <sub>T</sub> (30% dip in U <sub>T</sub> ) for 25 cycles <5% U <sub>T</sub> (>95% dip in U <sub>T</sub> ) for 5 seconds	Complies	Mains power quality should be that of a typical commercial or hospital environment.
Power Frequency (50/60 Hz) Magnetic Field IEC 61000-4-8	3 A/m	Complies	Power frequency magnetic fields should be at levels characteristic of a typical location in a typical commercial or hospital environment.

Note: U<sub>T</sub> is the AC mains voltage prior to application of the test level



## Medical-Grade Power Strip 97-466

Fully tested, certified and compliant to:

• UL 1363A

Input and Output: 120V~, 60 Hz, 15 A max



Made in China



© 2013 Ergotron, Inc.  
All rights reserved.

While Ergotron, Inc. makes every effort to provide accurate and complete information on the installation and use of its products, it will not be held liable for any editorial errors or omissions (including those made in the process of translation from English to another language), or for incidental, special or consequential damages of any nature resulting from furnishing this instruction and performance of equipment in connection with this instruction. Ergotron, Inc. reserves the right to make changes in the product design and/or product documentation without notification to its users. For the most current product information, or to know if this document is available in languages other than those herein, please contact Ergotron. No part of this publication may be reproduced, stored in a retrieval system, or transmitted in any form or by any means, electronic, mechanical, photocopying, recording or otherwise without the prior written consent of Ergotron, Inc., 1181 Trapp Road, Eagan, Minnesota, 55121, USA. Patents Pending and Patented U.S. & Foreign. Ergotron is a registered trademark of Ergotron, Inc.

**Americas Sales and  
Corporate Headquarters**

St. Paul, MN USA  
(800) 888-8458  
+1-651-681-7600  
[www.ergotron.com](http://www.ergotron.com)  
[sales@ergotron.com](mailto:sales@ergotron.com)

**EMEA Sales**

Amersfoort, The Netherlands  
+31 33 45 45 600  
[www.ergotron.com](http://www.ergotron.com)  
[info.eu@ergotron.com](mailto:info.eu@ergotron.com)

**APAC Sales**

Tokyo, Japan  
[www.ergotron.com](http://www.ergotron.com)  
[apaccustomerservice@ergotron.com](mailto:apaccustomerservice@ergotron.com)

**Worldwide OEM Sales**

[www.ergotron.com](http://www.ergotron.com)  
[info.oem@ergotron.com](mailto:info.oem@ergotron.com)