

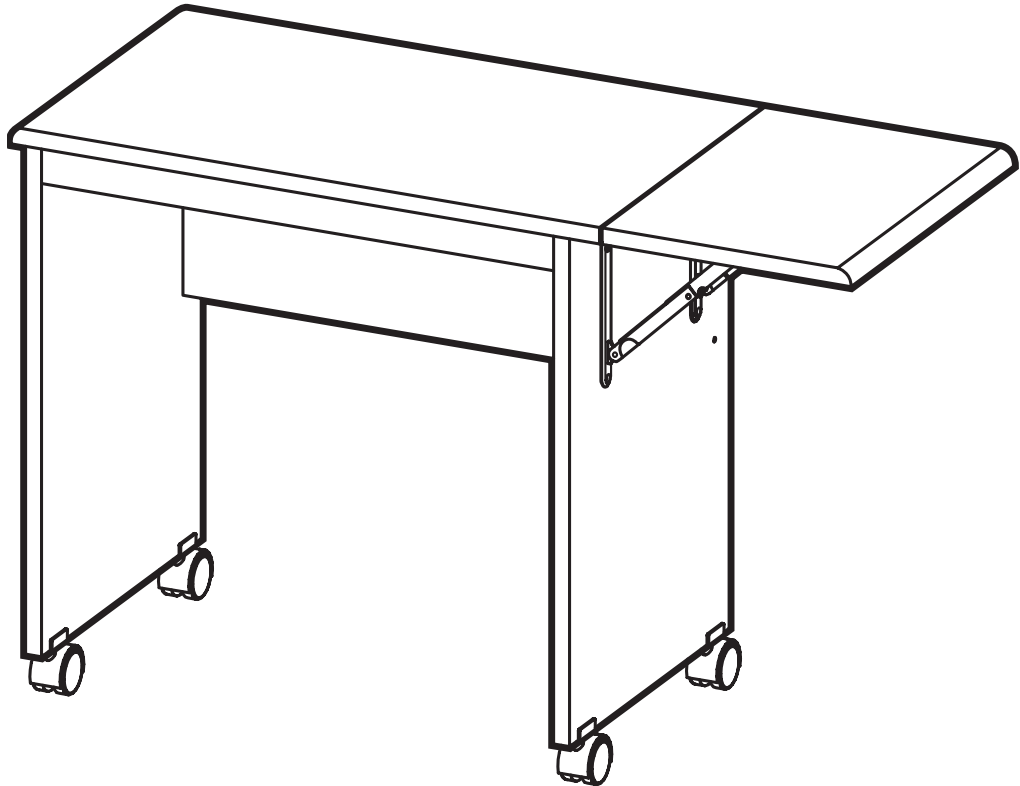

TSS

TYPING STAND



IMPORTANT!

Assembly may require the assistance of another person.

Before you begin assembly:

READ THE DIRECTIONS all the way through one time. This will speed up the process and help you understand the sequence of steps.

COUNT THE PARTS AND HARDWARE before assembly. This ensures you have received all necessary parts before you begin.

TOOLS: You may need a Phillips head screwdriver, a medium slotted screwdriver or a plastic mallet. To protect your new furniture from damage during assembly, it is recommended to work on a carpeted surface.

In the event any parts are missing from this package, send your name, address, telephone number, and a description of the missing part(s) to: PARTS, Box 1420, Missoula, MT 59806 or call: 1-800-769-5693 or FAX 1-800-445-5281.

CAUTION: On assemblies requiring glue, make sure the unit is assembled correctly before gluing. Once this unit is assembled with glue, the manufacturer will not be responsible for damaged parts. Keep a damp cloth or sponge handy to wipe off excess glue.

To care for this furniture, simply wipe with a cloth dampened with glass cleaner containing ammonia-D.

PARTS DIAGRAM

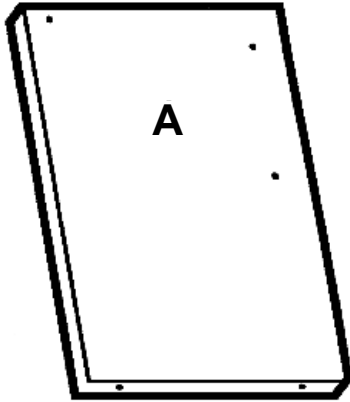

Left Side	05850241	1 ea.
-----------	----------	-------

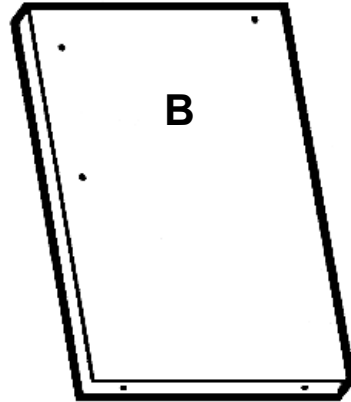

Right Side	05850241	1 ea.
------------	----------	-------

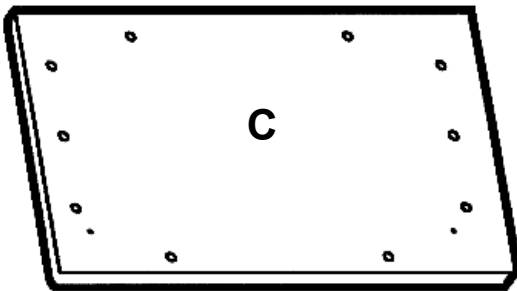

Work Surface	05850201	1 ea.
--------------	----------	-------

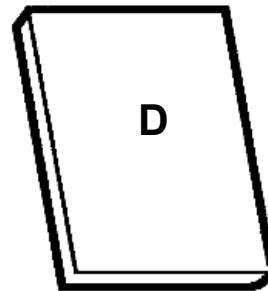

Drop Leaf	05850281	1 ea.
-----------	----------	-------



Back	05850252	1 ea.
------	----------	-------



Facia Strip	05850286	1 ea.
-------------	----------	-------

HARDWARE

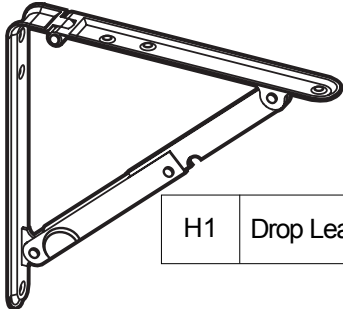

H1	Drop Leaf Support	401030	2 ea.
----	-------------------	--------	-------



H2	Flat Head Screw	H2040	12 ea.
----	-----------------	-------	--------



H4	Pan Head Screw	988056	4 ea.
----	----------------	--------	-------



H3	Angle Bracket	401200	2 ea.
----	---------------	--------	-------



H5	Glue	295020	1 ea.
----	------	--------	-------



H6	Dowel	195000	10 ea.
----	-------	--------	--------



H7	Confirmat Screw	950100	4 ea.
----	-----------------	--------	-------



H8	Caster Bracket	402303	4 ea.
----	----------------	--------	-------



H9	Caster Socket	402301	4 ea.
----	---------------	--------	-------



H10	Caster	402290	4 ea.
-----	--------	--------	-------

GLUING DIRECTIONS:

A. Fill hole ¼" full with glue.

GLUING DIRECTIONS:

B. Using a hammer, gently tap wood dowel into hole until bottomed out.

C. Wipe away any excess glue with a damp rag.

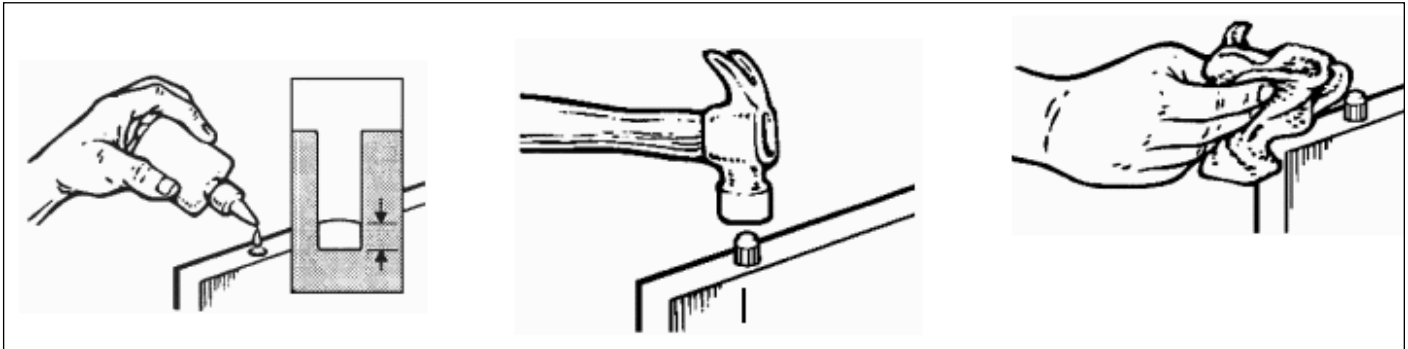

#1

Attach two Drop Leaf Support (H1) to the Right Side (B) using six Flat Head Screws (H2) in the pre-drilled holes as shown.

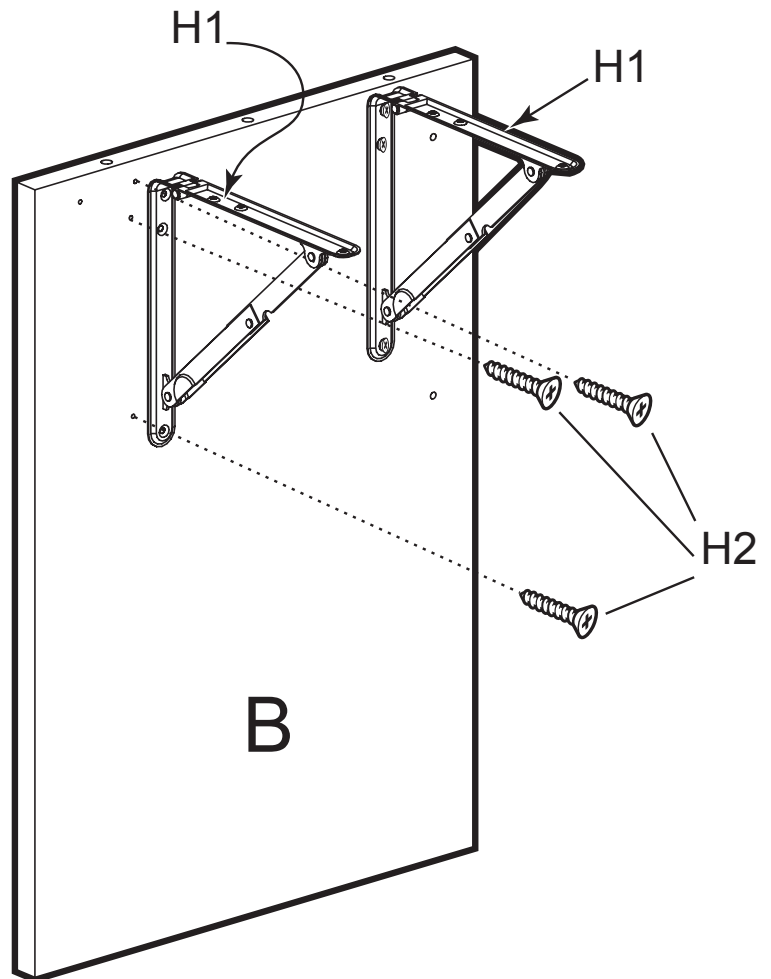

#2

Attach the Drop Leaf (D) using six Flat Head Screws (H2) as shown.

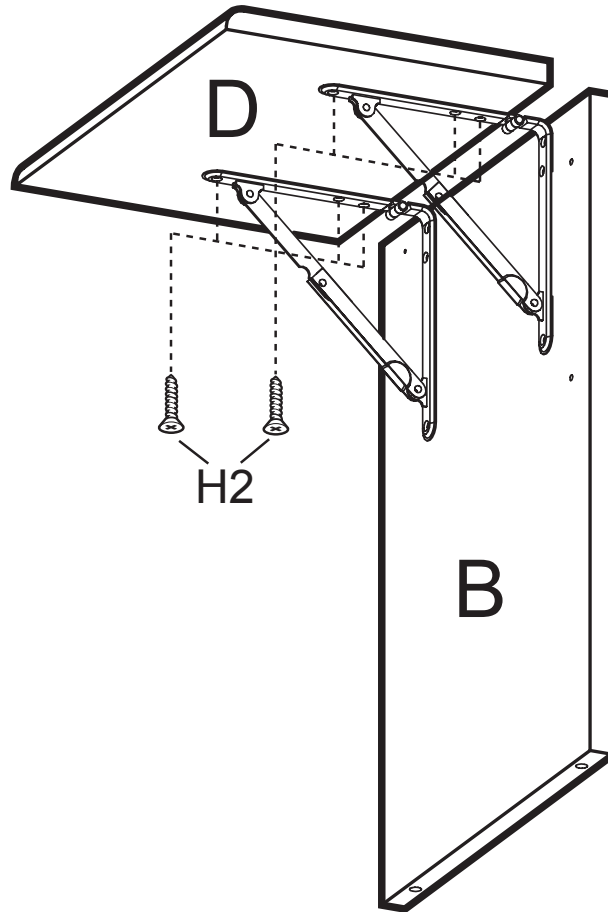

#3

Attach an Angle Bracket (H3) to the Right Side (B) using a Panhead Screw (H4) in the predrilled hole as shown.

Carefully following the gluing instructions from the first page, glue three wood dowels (H6) into the top of the side as shown.

NOTE: Be sure to wipe away any excess glue.

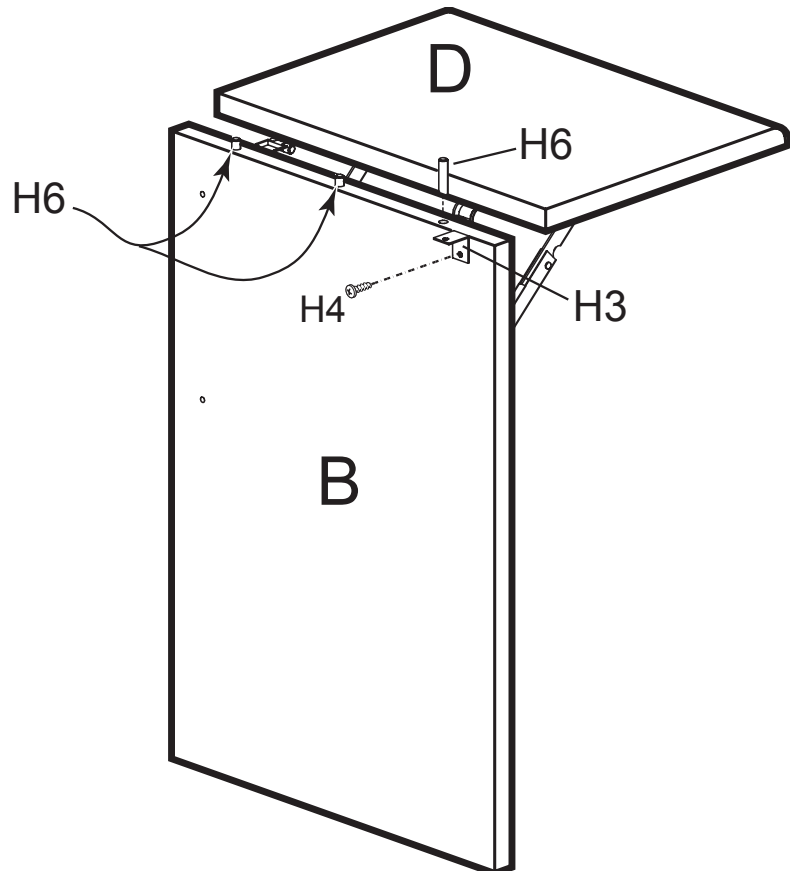
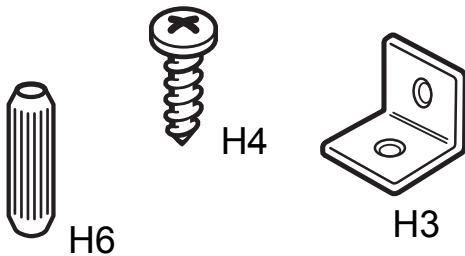

#4

Follow the same procedure as Step #3 for the Left Side (A).

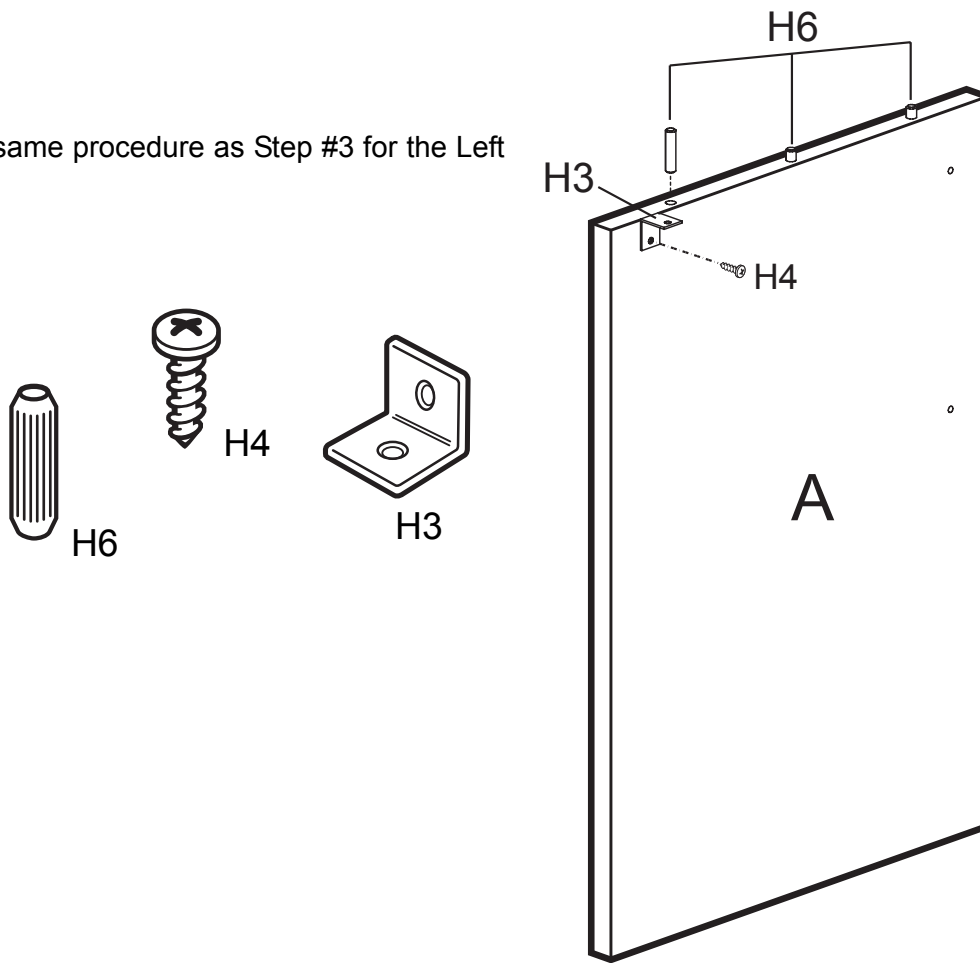

#5

Glue two Wood Dowels (H6) to the Back Panel (E) and Facia Strip (F).

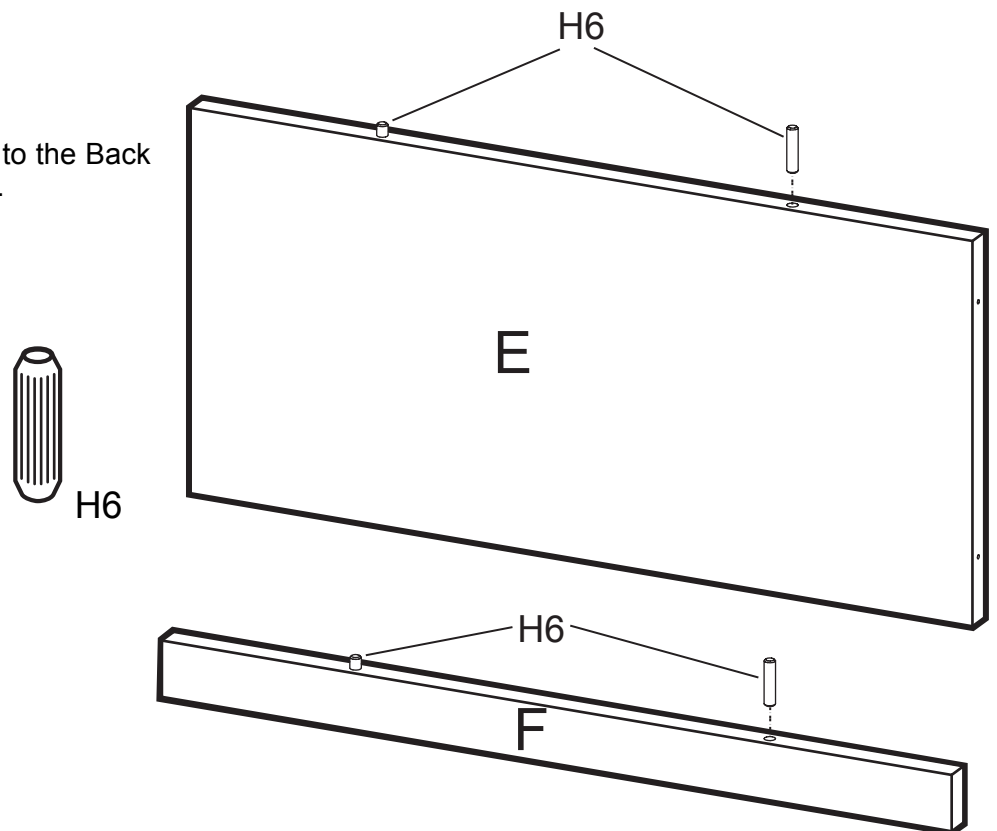

#6

Apply glue to dowels and position Left Side (A) onto the Work Surface (C) as shown. Wipe away any excess glue with a damp cloth.

Secure Angle Bracket (H3) to the Work Surface using a Panhead Screw (H4) in the pre-drilled hole.

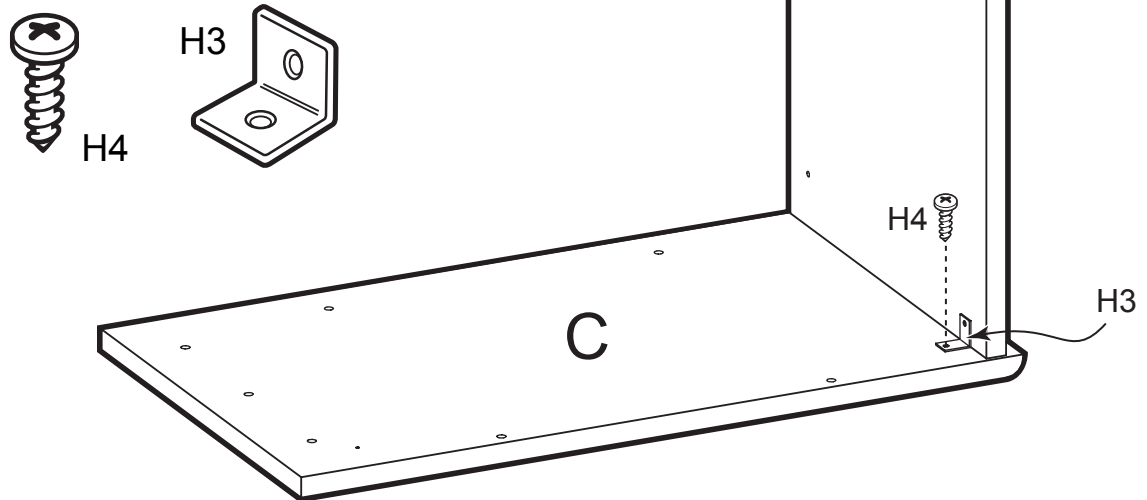

#7

Apply glue to dowels and position Back (E) onto the Worksurface as shown. Wipe away any excess glue with a damp cloth. Secure Back (E) to the Left Side (A) using two Confirmat Screws (H7).

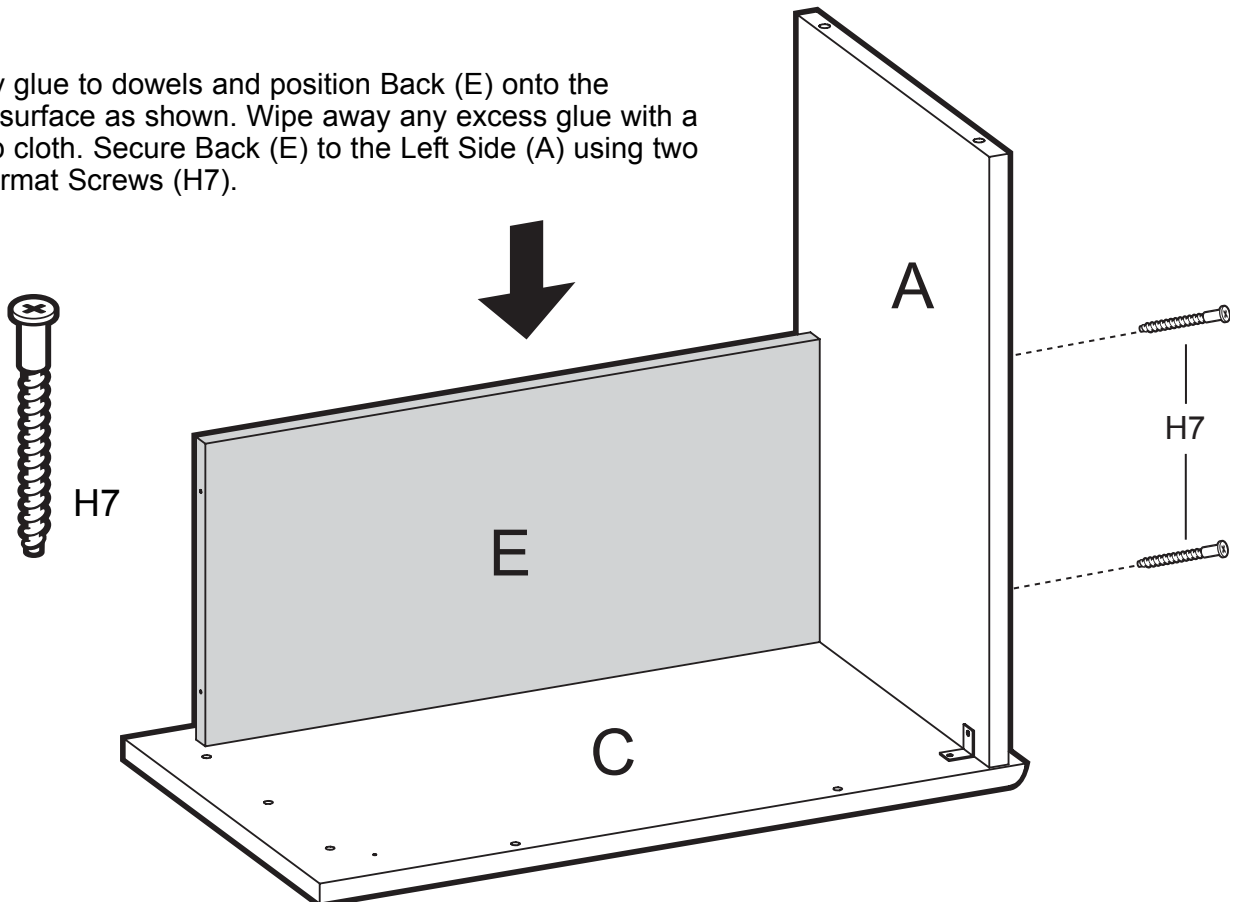

#8

Apply glue to dowels and position Facia Strip (F) onto the Worksurface as shown. Wipe away any excess glue with a damp cloth.

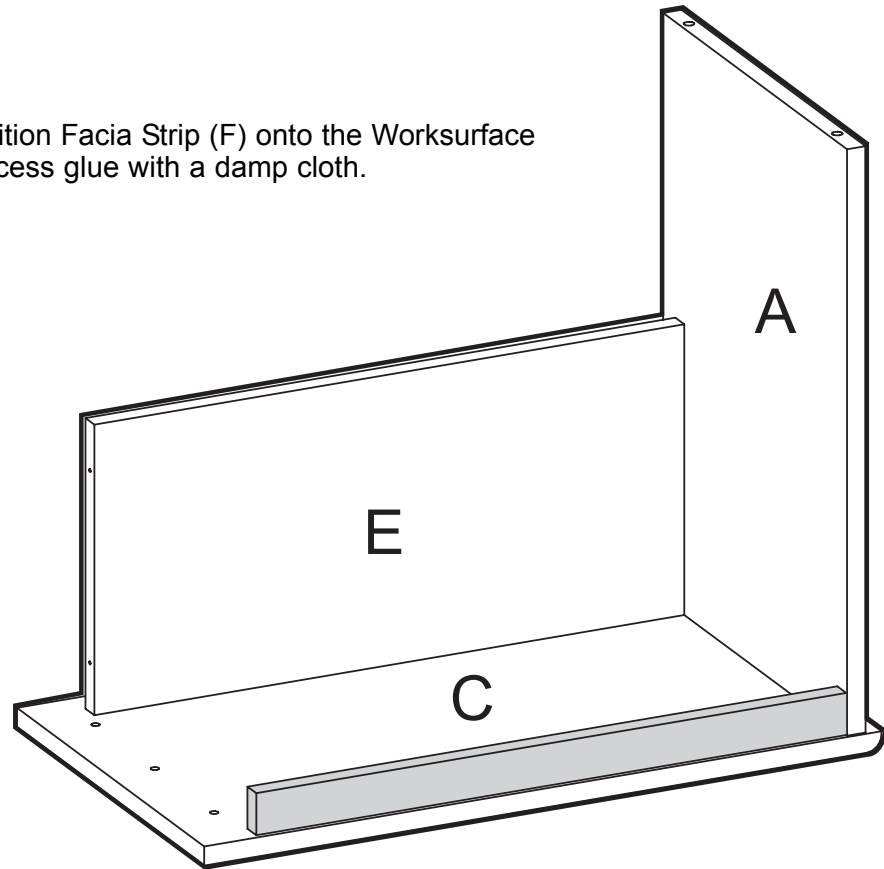

#9

Apply glue to dowels and position Right Side (B) onto the Worksurface as shown. Secure Back (E) to the Right Side using two Confirmat Screws (H7).

Secure Angle Bracket (H3) to the Worksurface using a Panhead Screw (H4) in the pre-drilled hole.

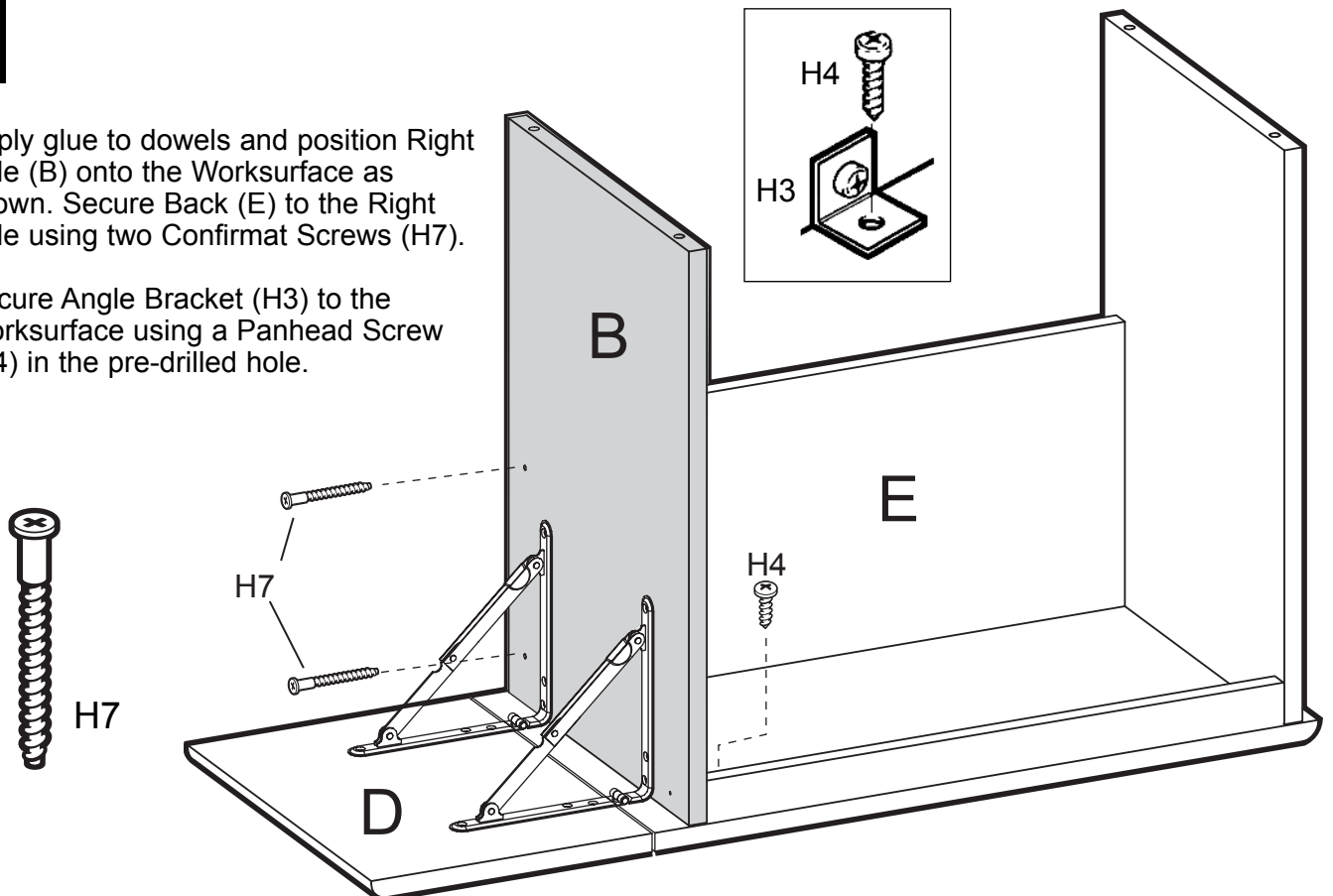

#10

Position Caster Brackets (H8) over corresponding holes in the bottom edges of Sides. Insert Caster Sockets (H9) into holes and tap until bottomed out against Caster Brackets (H8).

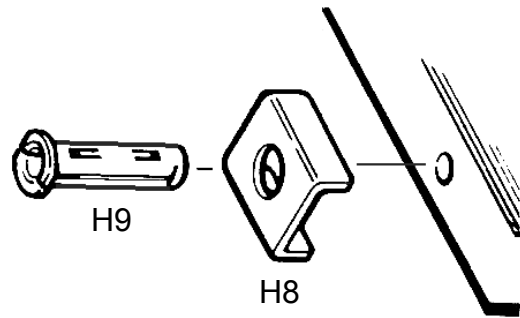

#11

Insert the Caster (H10) into the Caster Sockets and tap into place.

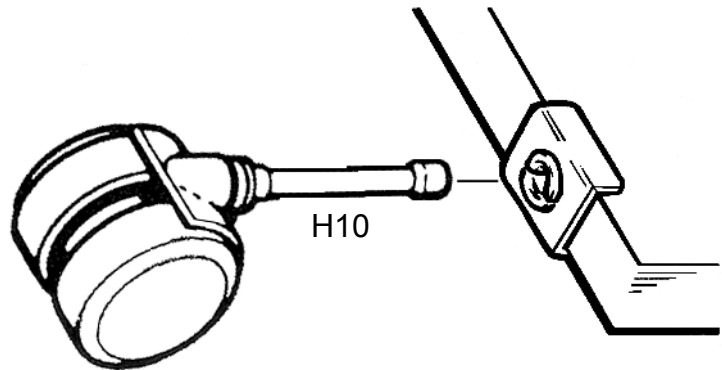

#12

Allow about ten minutes for the glue to set, then turn the unit upright.

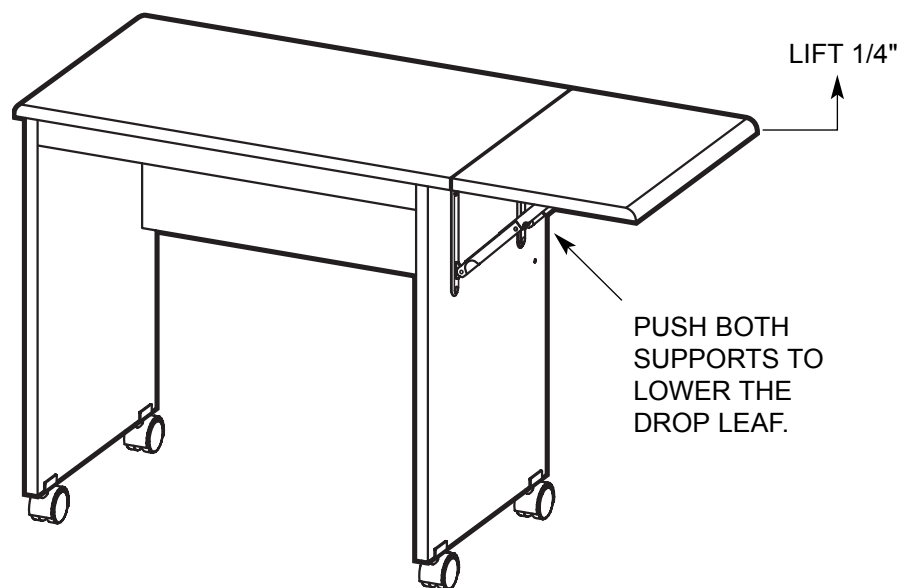

Your Typing Stand is now completely assembled and ready to use.