

NOTES:
 1) GEARBOX OIL: MOBIL-MOBIL GEAR 600XP-320

108706.00	90	1/4	13:1	135	105
108705.00	90	1/4	19:1	92	160
108704.00	90	1/4	29:1	60	238
108703.00	90	1/4	42:1	42	353
108702.00	90	1/4	95:1	18	750
108701.00	90	1/4	143:1	12	1030
108700.00	90	1/4	212:1	8	1087
CATALOG No.	VOLTS	INPUT HP	GEAR RATIO	RPM	F.L. TORQUE (LB-IN)

TOLERANCES UNLESS SPECIFIED		LEESON		ELECTRIC MOTORS GERMOTORS AND DRIVES		DRAWN IPG 6/9/10	
DEC	INCHES					CHK	
X	±.1					APPR	
XX	±.03	TITLE		OUTLINE		SCALE 1:2	
XXX	±.005	REF		48 FRAME DC - P1100 GEARBOX		031210	
XXXX	±.0005	MATL				FMF 108700.00	
RELEASED: REF. 031210 & 032031	IPG 6/9/2010	BY & DATE		FINISH		PAGE OF	
NO	REVISION	CHK	ANG	±1/2"	PREV	SIZE	DRAWING NO
	THIRD ANGLE PROJECTION	RFP				B	032033
		NETWORK FILE NAME		032033			REV

RBC PROPRIETARY AND CONFIDENTIAL INFORMATION

This document is the property of REGAL BELOIT CORPORATION ("RBC") including its subsidiaries and divisions and contains proprietary information of RBC. This document is loaned on the express condition that neither it nor the information contained therein shall be disclosed to others without the express written consent of RBC, and that the information shall be used by the recipient only as approved expressly by RBC. This document shall be returned to RBC upon its request. This document may be subject to certain restrictions under U.S. export control laws and regulations.

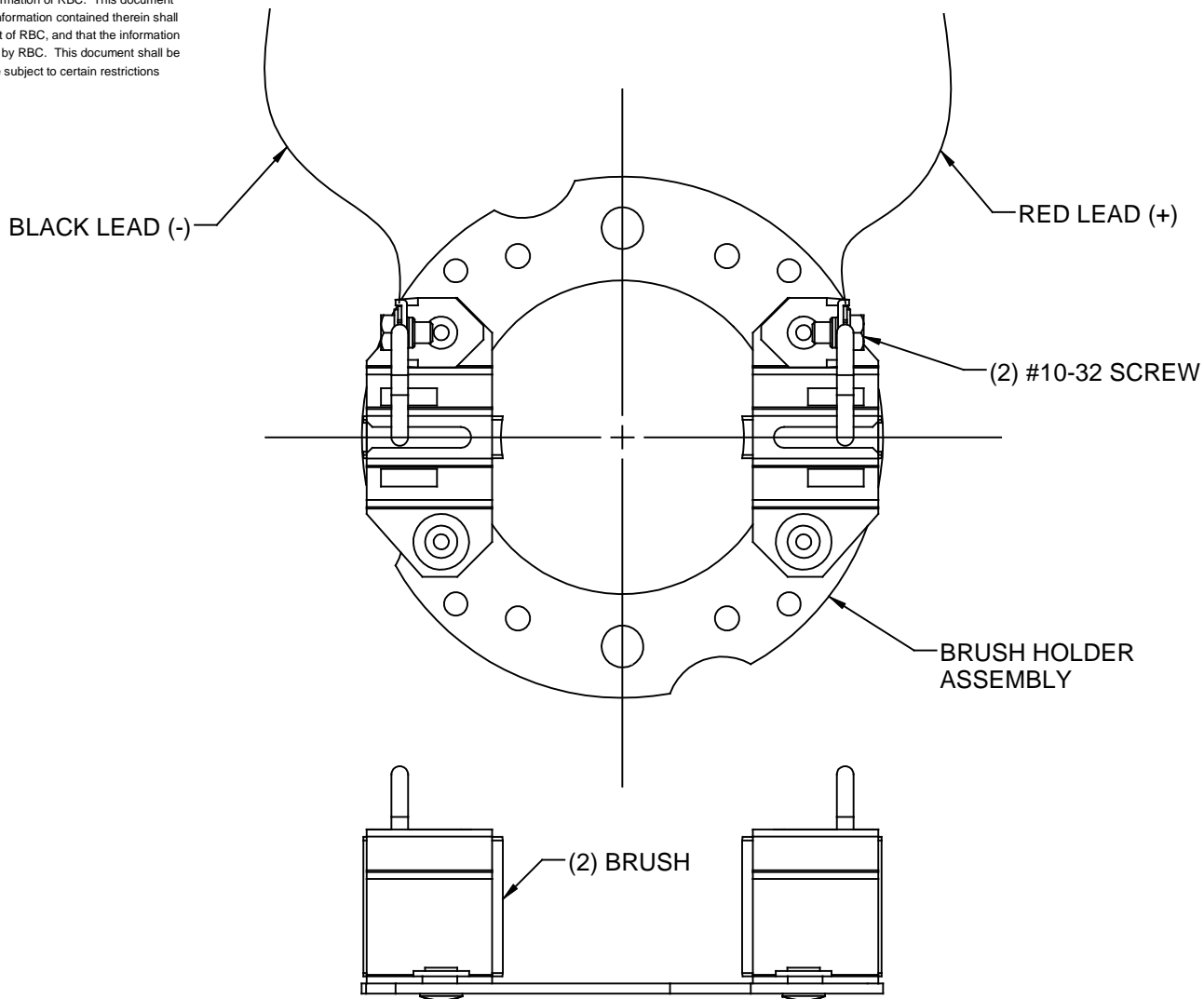

POLARITY: CCWLE

				TOLERANCES UNLESS SPECIFIED		 REGAL-BELOIT CORPORATION	DRAWN	IPG 12/10/07
				DEC	INCHES		CHK	RWS 12/10/07
				.X	±.1	APPR		
				.XX	±.01	TITLE	BRUSH/PLATE DRAWING	
01	INTERCHANGED RED AND BLACK LEADS	IPG 4/25/2008	BC	.XXX	±.005		SCALE	5:8
	RELEASED	IPG 12/10/2007	RWS	.XXXX	±.0005		REF	PR070348
NO	REVISION	BY & DATE	CHK	ANG	±1/2°	MAT'L	FMF	108022.75
				RFP		FINISH	PAGE	OF
THIRD ANGLE PROJECTION				NETWORK FILE NAME		PREV	SIZE	DRAWING NO
							A	499954.01
								REV
								01