



A Regal Brand

Catalog # : M1145038.00

Product Type: ACSG

Description:

Model: M1145038.00

Stock: Y

Engineering Data

RPM	43/36	Volts	110/220	Volts	
HP/KW	.16/.16	F.L. Amps	2.8/1.4	F.L. Amps	2/1
Frame	38	S. F Amps		S. F Amps	
Max Amb	40	Hertz		Phase	1
Insul Class	F4	Duty	CONT	TYPE	PF
		Serv. Factor	1.0/1.0	PF	
Eff 100%		Eff 75%		Enclosure	TEFC
Protection	NOT	Therm.Prot.		Bearing OPE	6201-13
Design		Code	D	Bearing PE	6201-13
UL	Yes	CSA	Yes	CE	Yes
Series	13	Nameplate	M1004149.02	Lubrication	
		Overrlung Ld.	235	Shaft Type	RIGHT-ANGLE

Motor Wt.	19 LB	Mounting	SPECIAL	Rotation	RECONN
Carton Label	Subfrac Individual	Assembly	M1040447		
Winding	MP38440	Shaft Dia.	5/8	Ext. Diag2.	
GROUP :	3 B	Paint	M1305027.01	Packaging	M1307027.01
Test Card	01	Outline	M1030422	Cust Part No	

Form Factor		RMS Amps	
Torque		Peak	
AB Code		Peak@DegC	
Resistance			
Connection		Const Torque	

Rework Status	Rework TYPE
---------------	-------------

4Explosion Proof		2Brake Motors
Temp Op Code		FORCE
Class	GROUP	VDC
Class	GROUP	ADC

M1030422.00

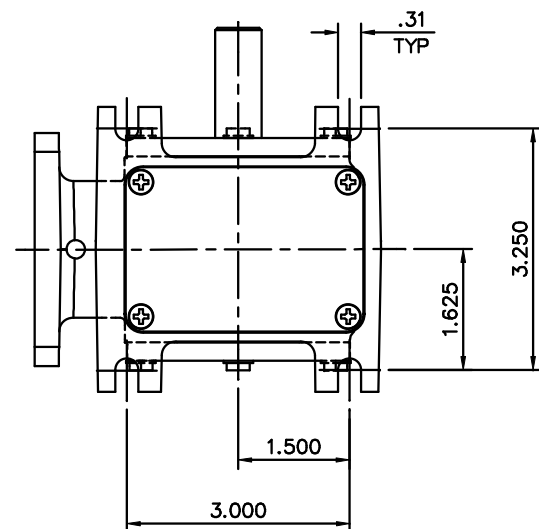
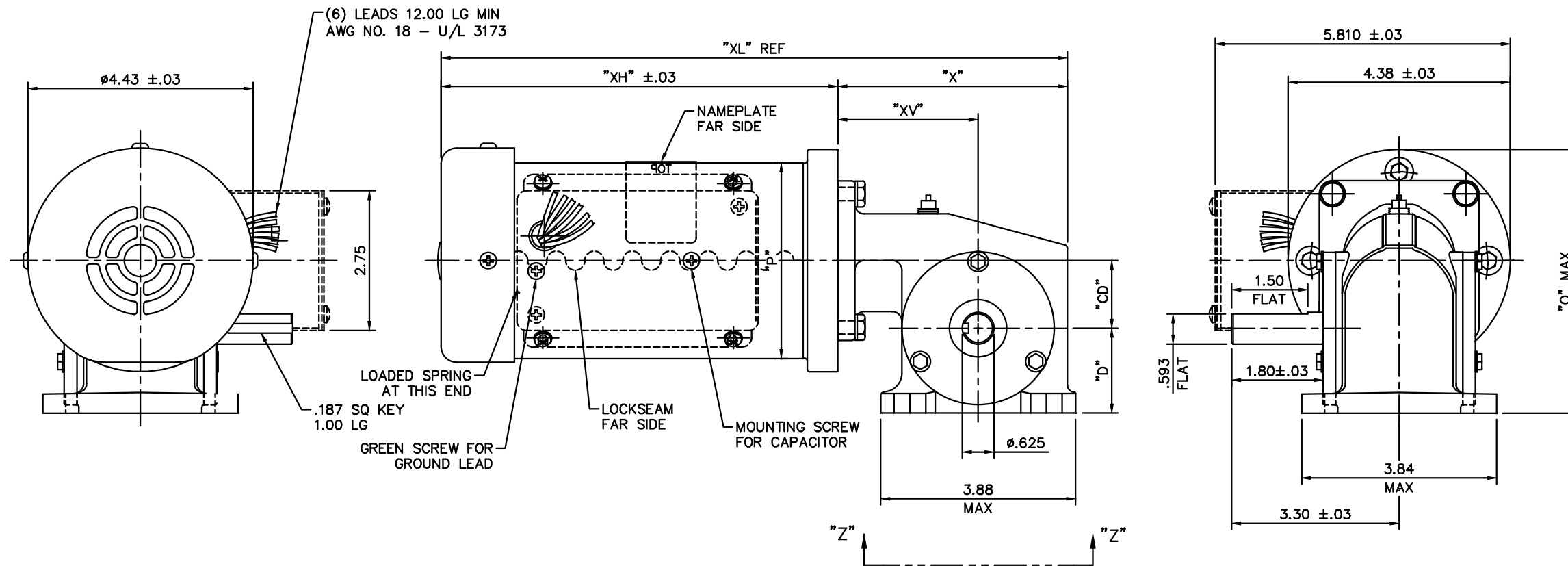

VIEW Z-Z

CATALOG NUMBER	SPEED RANGE RPM	FULL LOAD TORQUE LB.-IN.	INPUT HP	OVERHUNG LOAD LBS.	GEARMOTOR TYPE & FRAME	RATIO TO 1	"P"	"X"	"XH"	"XL"	"XV"	"D"	"O"	"CD"
M1145037.00	29	110	1/6	235	13F60-38F	60	3.85	4.50	7.81	12.31	2.74	1.67	5.20	1.333
M1145038.00	43	113	1/6	235	13F40-38F	40	3.85	4.50	7.81	12.31	2.74	1.67	5.20	1.333
M1145039.00	85	75	1/6	235	13F20-38F	20	3.85	4.50	7.81	12.31	2.74	1.67	5.20	1.333
M1145040.00	170	43	1/6	235	13F10-38F	10	3.85	4.50	7.81	12.31	2.74	1.67	5.20	1.333
M1145041.00	340	23	1/6	235	13F05-38F	5	3.85	4.50	7.81	12.31	2.74	1.67	5.20	1.333
M1145082.00	57	95	1/6	235	13F30-38F	30	3.85	4.50	7.81	12.31	2.74	1.67	5.20	1.333

NO.	REVISION	BY & DATE	CHK	ANG	TOLERANCES UNLESS SPECIFIED	FINISH	SIZE	DRAWING NO.	REV.
08	CHANGED TO DIE CAST GEARBOX PER ECN 06-3024.	RPB 7/13/06	BC		DEC. INCHES		B	M1030422.00	08
07	CORRECTED VIEW "Z-Z" PER OTHER TWO VIEWS	BPW 03/15/02			.X ±.1				
06	ADDED CATALOG NUMBER M1145082.00 AND UPDATED F.L. TORQUE TO MATCH THE CATALOG	SAD 01/13/99			.XX ±.03 .XXX ±.005 .XXXX ±.0005				

THIS DRAWING IN DESIGN AND DETAIL IS OUR PROPERTY AND MUST NOT BE USED EXCEPT IN CONNECTION WITH OUR WORK ALL RIGHTS OF DESIGN AND INVENTION ARE RESERVED THIS IS AN ELECTRONICALLY GENERATED DOCUMENT - DO NOT SCALE THIS PRINT

RFP CAD FILE M1030422

LEESON ELECTRIC MOTORS GEARMOTORS AND DRIVES

TITLE OUTLINE DRAWING 38 FRAME A.C. RIGHT ANGLE GEARMOTOR

SCALE 1=2

DRAWN SPV 02/13/95

CHK APPD REF FMF PREV

M1005040.02

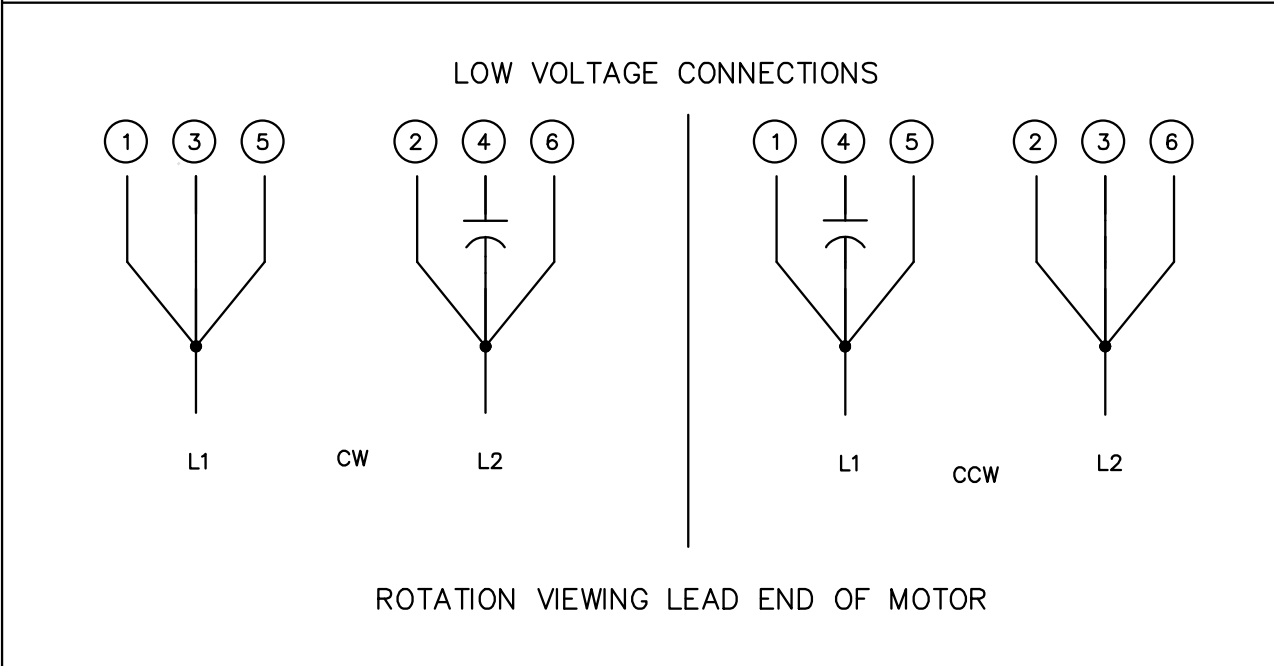
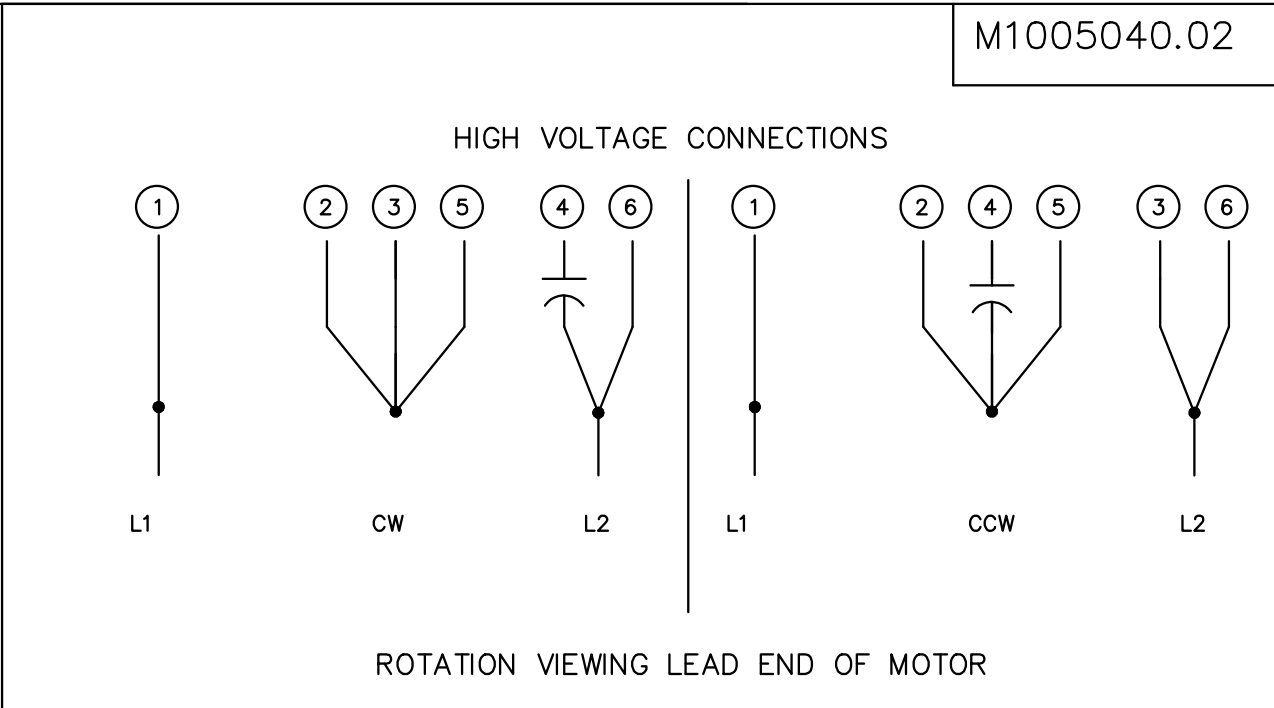
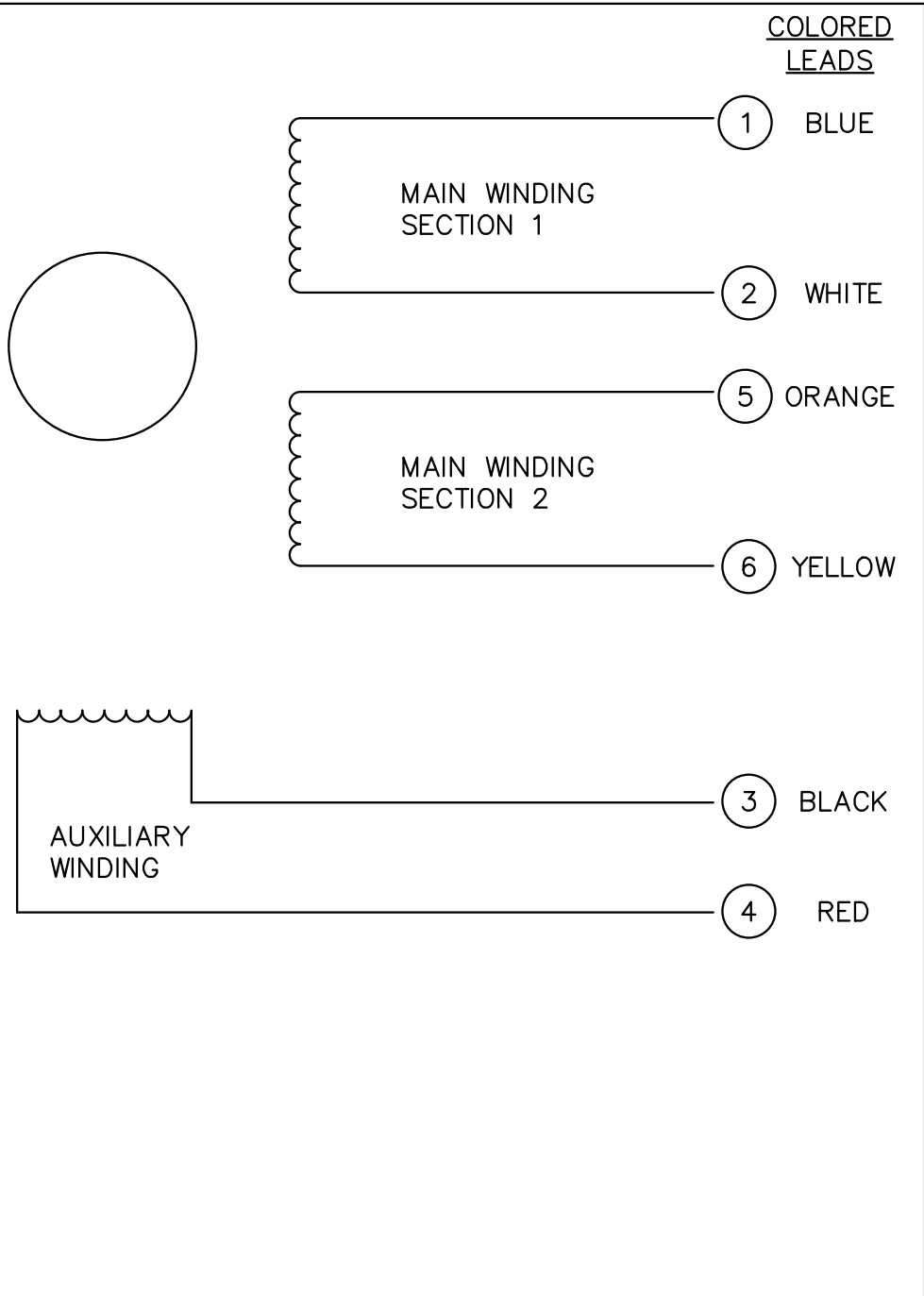

				TOLERANCES UNLESS OTHERWISE SPECIFIED		LEESON ELECTRIC CORPORATION		TITLE EXTERNAL WIRING DIAGRAM DUAL VOLTAGE DUAL ROTATION	
				DECIMALS					
				.00	± .01	DRAWN	DK	MAT'L.	
02	REDRAWN ON CAD	AJR	6/28/99	.000	± .005	CH'K'D.	10/3/91		
01	REMOVED CAP FROM LEFT DIAGRAM	DD	9/16/95	.0000	± .0005	APPR.	10/3/91	DRAWING NO. M1005040.02	
NO.	REVISION	BY	DATE	FRACTIONS	± 1/64	SCALE	NONE		
THIS DRAWING IN DESIGN AND DETAIL IS OUR PROPERTY AND MUST NOT BE USED EXCEPT IN CONNECTION WITH OUR WORK ALL RIGHTS OF DESIGN AND INVENTION ARE RESERVED				ANGLES	± 1/2°	REF.		FINISH	SIZE A
				INCH/MM		FMF	PR91376	LECO CORP.	