



A Regal Brand

Catalog # : M1125084.00

Product Type: ACSG

Description:

Model: M1125084.00

Stock: Y

Quote: Price:

Date: 02/08/2018



A Regal Brand

Catalog # : M1125084.00

Product Type: ACSG

Description:

Model: M1125084.00

Stock: Y

Engineering Data

RPM	173/144	Volts	115/230	Volts	
HP/KW	.06/.06	F.L. Amps	.9/.45	F.L. Amps	.9/.45
Frame	31	S. F Amps		S. F Amps	
Max Amb	40	Hertz		Phase	1
Insul Class	F4	Duty	CONT	TYPE	PN
		Serv. Factor	1.0/1.0	PF	
Eff 100%		Eff 75%		Enclosure	TENV
Protection	NOT	Therm.Prot.		Bearing OPE	608
Design		Code	C	Bearing PE	6201-13
UL	Yes	CSA	Yes	CE	Yes
Series	10	Nameplate	M1004149.02	Lubrication	
		Overrlung Ld.	185	Shaft Type	RIGHT-ANGLE

Motor Wt.	10 LB	Mounting	SPECIAL	Rotation	RECONN
Carton Label	Subfrac Individual	Assembly			
Winding	MP3141	Shaft Dia.	1/2	Ext. Diag2.	
GROUP :	3 D	Paint	M1305027.01	Packaging	M1307027.01
Test Card	01	Outline	M1030420	Cust Part No	

Form Factor		RMS Amps	
Torque		Peak	
AB Code		Peak@DegC	
Resistance			
Connection		Const Torque	

Rework Status	Rework TYPE
---------------	-------------

4Explosion Proof		2Brake Motors
Temp Op Code		FORCE
Class	GROUP	VDC
Class	GROUP	ADC

Quote: Price:

Date: 02/08/2018

M1030420.00

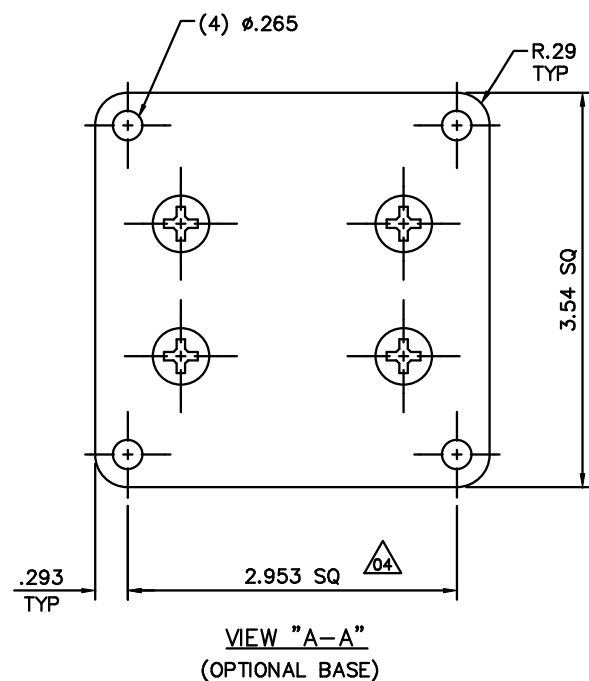
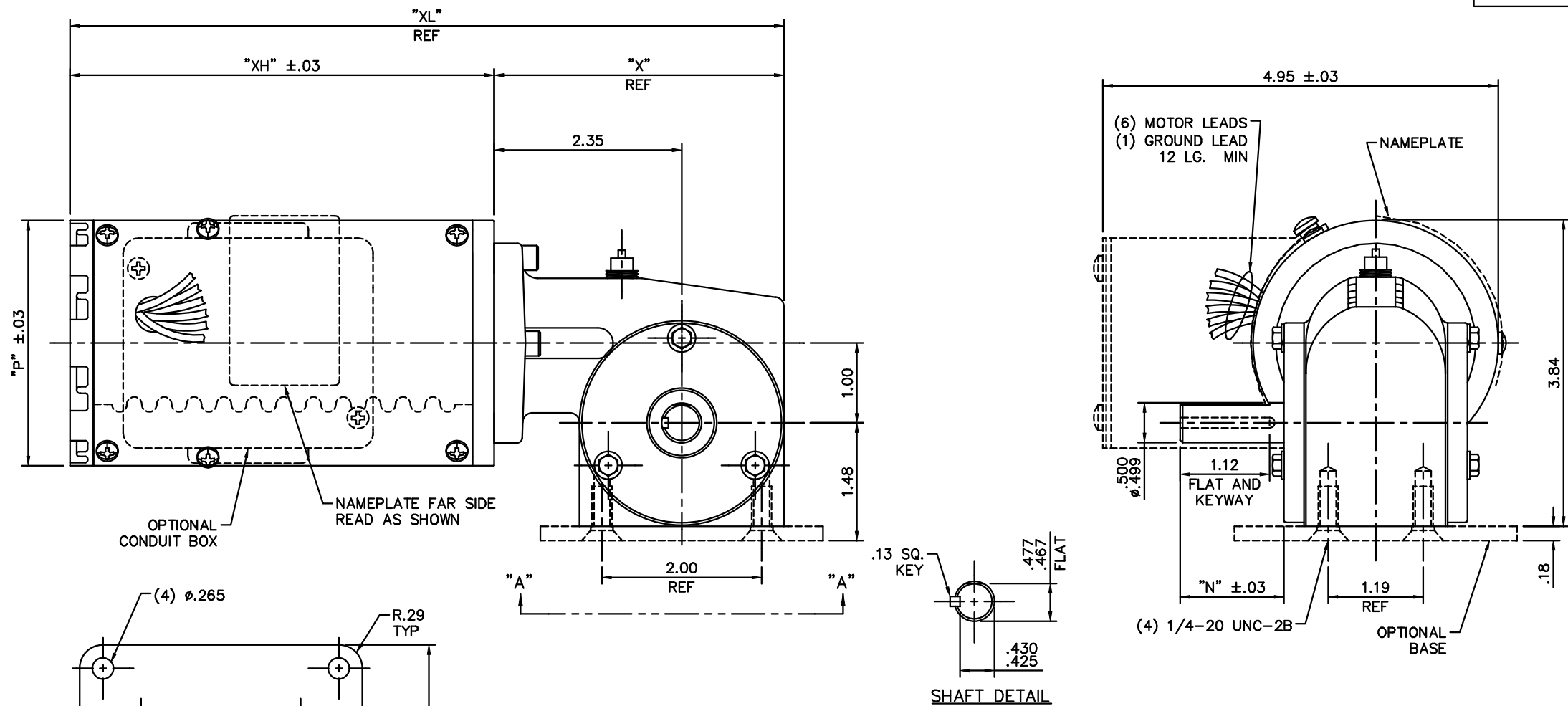

CATALOG NUMBER	SPEED RANGE RPM	FULL LOAD TORQUE LB.-IN.	INPUT HP	OVERHUNG LOAD LBS.	RATIO TO 1	"P"	"X"	"XH"	"XL"	"N"
M1125084.00	173	14	1/15	185	10	3.07	3.63	5.31	8.94	1.30
M1125083.00	85	24	1/15	185	20	3.07	3.63	5.31	8.94	1.30
M1125082.00	58	40	1/15	185	30	3.07	3.63	5.31	8.94	1.30
M1125081.00	43	34	1/15	185	40	3.07	3.63	5.31	8.94	1.30
M1125080.00	28	37	1/15	185	60	3.07	3.63	5.31	8.94	1.30

NO.	REVISION	BY & DATE	CHK	ANG	±1/2"	TOLERANCES UNLESS SPECIFIED	DEC.	INCHES	FINISH	SIZE	DRAWING NO.	REV.
06	ADDED "N" DIM TO CHART	RLW 7/8/05								B	M1030420.00	06
05	"D" DIM. WAS 1.30 & UPDATE CHART PER ECO 05-1249	LST 6/24/05										
04	BASE DIM, 2.953 SQ WAS 3.54, REV'D TO MATCH PART	BJB 05/10/05										
03	DIM 1.12 WAS .93	SAD 05/06/98										
02	GEAR SYSTEMS GEARBOX WAS HUB CITY GEARBOX	SAD 03/31/98										
01	UPDATED ITEM BLOCK	SPV 04/26/95										
THIS DRAWING IN DESIGN AND DETAIL IS OUR PROPERTY AND MUST NOT BE USED EXCEPT IN CONNECTION WITH OUR WORK ALL RIGHTS OF DESIGN AND INVENTION ARE RESERVED THIS IS AN ELECTRONICALLY GENERATED DOCUMENT - DO NOT SCALE THIS PRINT										RFP	M1030420	
										DIST		



M1005040.02

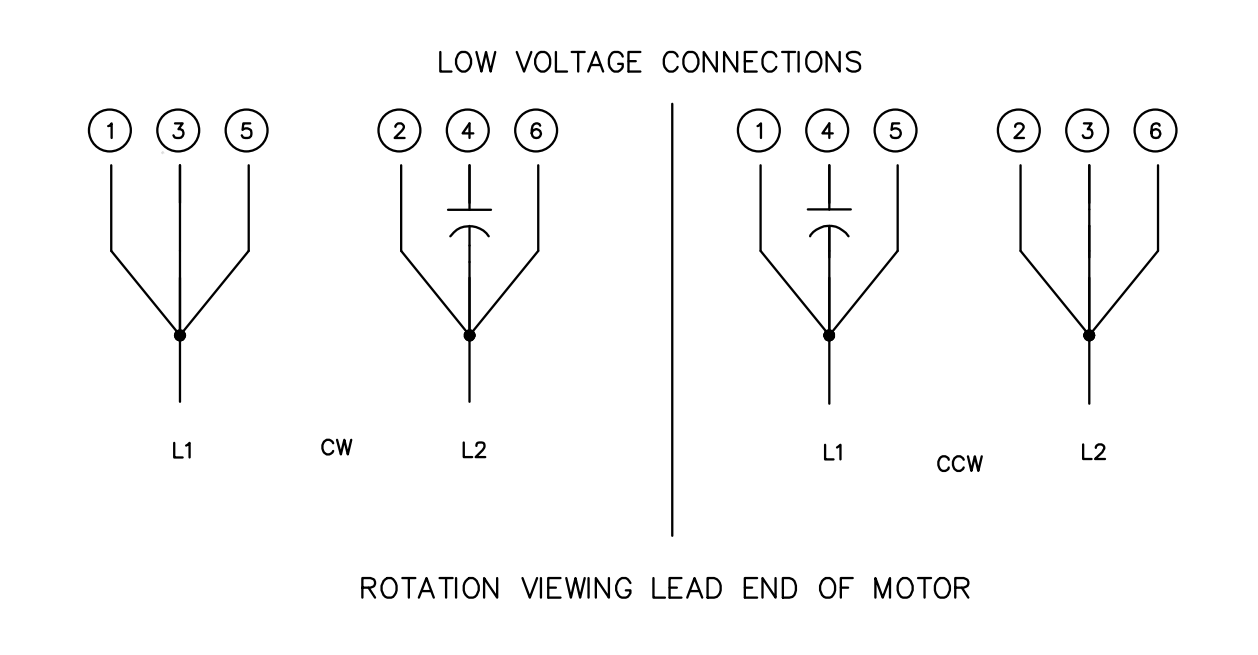
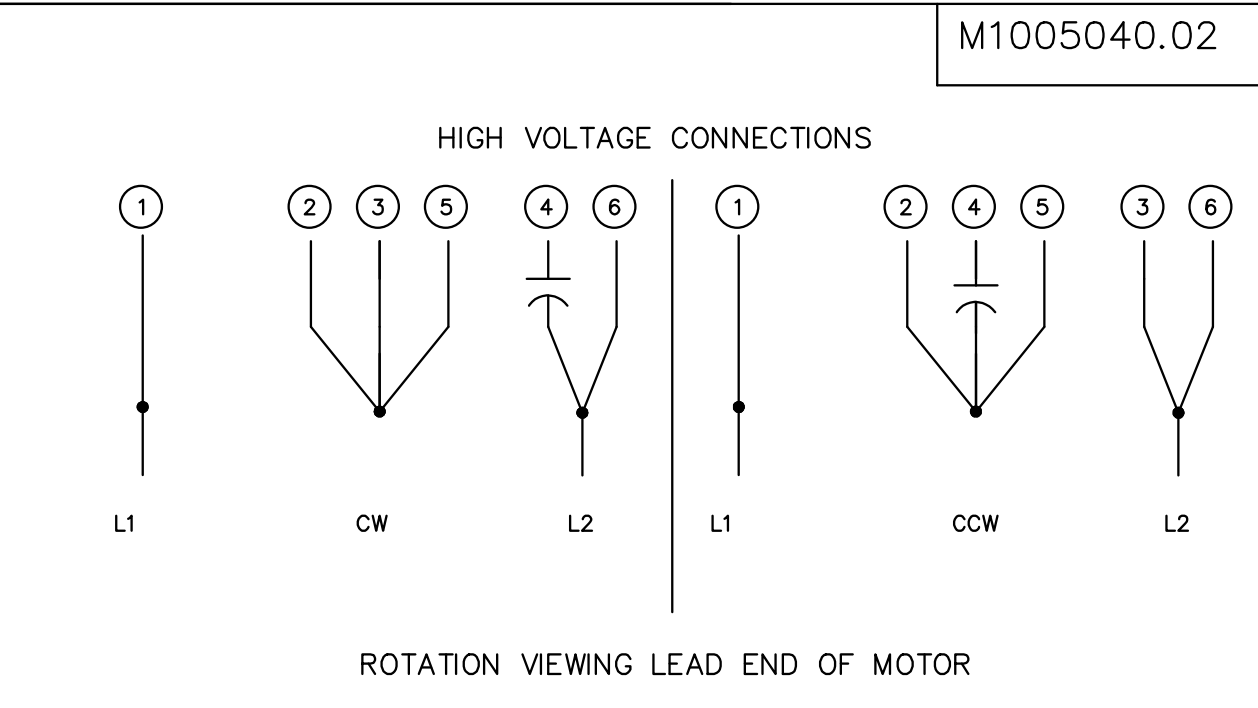
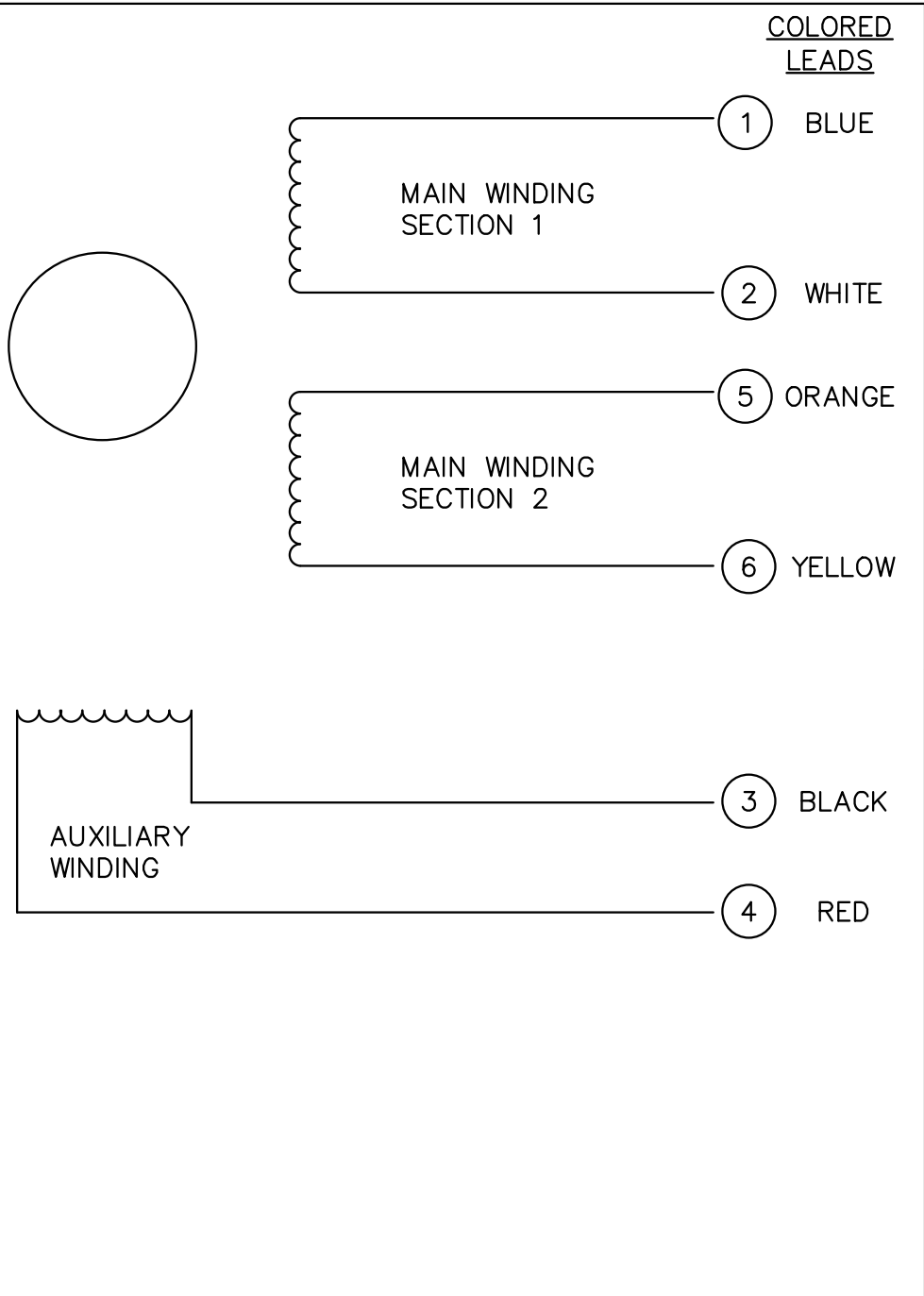

				TOLERANCES UNLESS OTHERWISE SPECIFIED		LEESON ELECTRIC CORPORATION		TITLE EXTERNAL WIRING DIAGRAM DUAL VOLTAGE DUAL ROTATION	
				DECIMALS					
				.00	± .01	DRAWN	DK	MAT'L.	
02	REDRAWN ON CAD	AJR	6/28/99	.000	± .005	CH'K'D.	10/3/91		
01	REMOVED CAP FROM LEFT DIAGRAM	DD	9/16/95	.0000	± .0005	APPR.	10/3/91	DRAWING NO. M1005040.02	
NO.	REVISION	BY	DATE	FRACTIONS	± 1/64	SCALE	NONE		
THIS DRAWING IN DESIGN AND DETAIL IS OUR PROPERTY AND MUST NOT BE USED EXCEPT IN CONNECTION WITH OUR WORK ALL RIGHTS OF DESIGN AND INVENTION ARE RESERVED				ANGLES	± 1/2°	REF.		FINISH	SIZE A
				INCH/MM		FMF	PR91376	LECO CORP.	