

SHAFT DETAIL
SCALE 2:1

CATALOG No.	VOLTS	HP	RATIO	TORQUE IN-LB	RPM	"XL" INCH	"XH" INCH	"X" INCH
M1115000.00	90	1/20	90:1	100	20	9.30	7.74	3.24
M1115001.00	90	1/20	180:1	100	10	9.30	7.74	3.24
M1115002.00	90	1/40	450:1	40	4	9.30	7.74	3.24
M1125002.00	90	1/17	60:1	100	30	8.74	7.18	2.68
M1125003.00	90	1/17	30:1	56	60	8.74	7.18	2.68
M1125004.00	90	1/17	18:1	36	100	8.74	7.18	2.68
M1125005.00	90	1/17	12:1	24	150	8.46	6.90	2.40
M1125006.00	90	1/17	6:1	10	300	8.46	6.90	2.40
M1125033.00	180	1/17	6:1	10	300	8.46	6.90	2.40
M1125034.00	180	1/17	12:1	24	150	8.46	6.90	2.40
M1125035.00	180	1/17	18:1	36	100	8.74	7.18	2.68
M1125036.00	180	1/17	30:1	56	60	8.74	7.18	2.68
M1125037.00	180	1/17	60:1	100	30	8.74	7.18	2.68
M1125046.00	180	1/40	450:1	40	4	9.30	7.74	3.24
M1125047.00	180	1/20	180:1	100	10	9.30	7.74	3.24
M1125048.00	180	1/20	90:1	100	20	9.30	7.74	3.24

				TOLERANCES UNLESS SPECIFIED		LEESON ELECTRIC MOTORS GEARMOTORS AND DRIVES		DRAWN RWS 3/7/05	
				DEC.	INCHES			CHK RPB 3/8/05	APPD
						TITLE		SCALE 1=2	
						30 FRAME DC-PZ GEARBOX		REF M1115000-1125048	
00 RELEASED COMM CONVERSION PROJECT				RWS 4/13/05		MAT'L		FPM M1115002.00	
NO. REVISION				BY & DATE		FINISH		PREV	
THIS DRAWING IN DESIGN AND DETAIL IS OUR PROPERTY AND MUST NOT BE USED EXCEPT IN CONNECTION WITH OUR WORK ALL RIGHTS OF DESIGN AND INVENTION ARE RESERVED THIS IS AN ELECTRONICALLY GENERATED DOCUMENT - DO NOT SCALE THIS PRINT				RFP		CAD FILE M1030957		SIZE B DRAWING NO. M1030957.00	
				DIST				REV. 00	

D.C. MOTORS

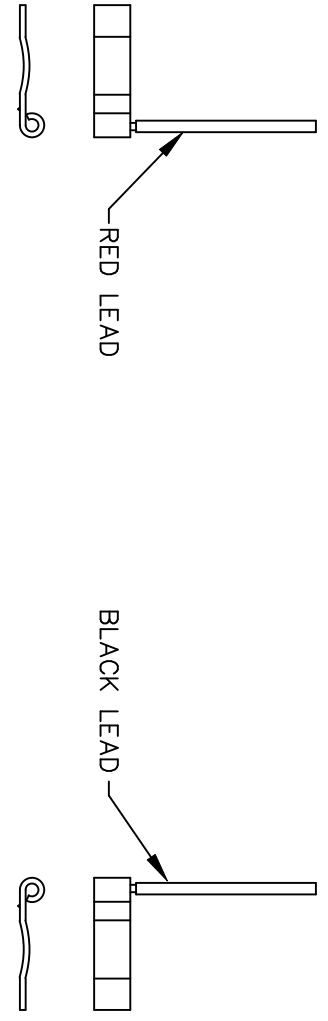
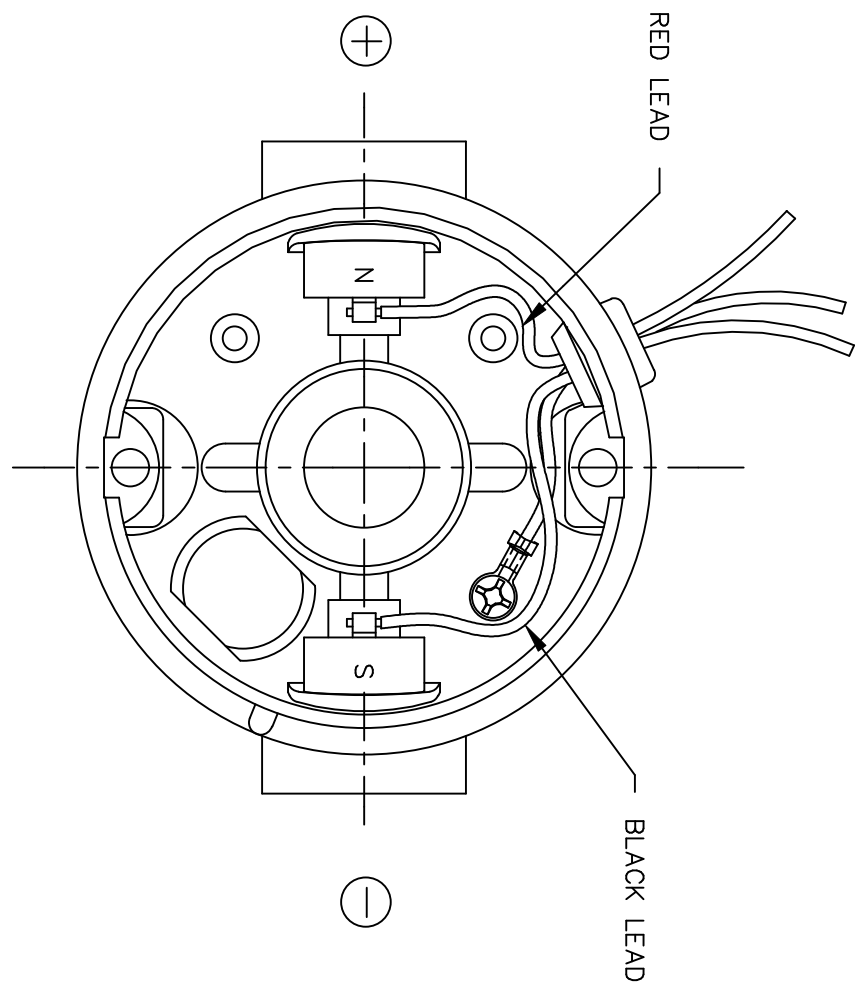

EXTERNAL CONNECTIONS FOR CW ROTATION
 VIEWING LEAD END OF MOTOR WITH RED LEAD
 POSITIVE (+) AND BLACK LEAD NEGATIVE (-)
 FOR CCW ROTATION REVERSE POLARITY

				TOLERANCES UNLESS SPECIFIED		 ELECTRIC MOTORS GEARMOTORS AND DRIVES	DRAWN RWS 3/15/05 CHK RPB 3/15/05 APPD
				DEC.	INCHES		SCALE 1=1
				.X	±.1		REF 901.706
				.XX	±.01		FMF
				.XXX	±.005		PREV
00	RELEASED COMM CONVERSION PROJECT	RWS 4/13/05	RPB	.XXXX	±.0005	MAT'L.	
NO.	REVISION	BY & DATE	CHK	ANG	±1/2"	FINISH	
THIS DRAWING IN DESIGN AND DETAIL IS OUR PROPERTY AND MUST NOT BE USED EXCEPT IN CONNECTION WITH OUR WORK ALL RIGHTS OF DESIGN AND INVENTION ARE RESERVED THIS IS AN ELECTRONICALLY GENERATED DOCUMENT - DO NOT SCALE THIS PRINT				RFP	CAD FILE	M100530201	SIZE A
				DIST			DRAWING NO. M1005302.01
							REV. 00