

SHAFT DETAIL
SCALE 2:1

CATALOG No.	VOLTS	HP	RATIO	TORQUE IN-LB	RPM	"XL" INCH	"XH" INCH	"X" INCH
M1115000.00	90	1/20	90:1	100	20	9.30	7.74	3.24
M1115001.00	90	1/20	180:1	100	10	9.30	7.74	3.24
M1115002.00	90	1/40	450:1	40	4	9.30	7.74	3.24
M1125002.00	90	1/17	60:1	100	30	8.74	7.18	2.68
M1125003.00	90	1/17	30:1	56	60	8.74	7.18	2.68
M1125004.00	90	1/17	18:1	36	100	8.74	7.18	2.68
M1125005.00	90	1/17	12:1	24	150	8.46	6.90	2.40
M1125006.00	90	1/17	6:1	10	300	8.46	6.90	2.40
M1125033.00	180	1/17	6:1	10	300	8.46	6.90	2.40
M1125034.00	180	1/17	12:1	24	150	8.46	6.90	2.40
M1125035.00	180	1/17	18:1	36	100	8.74	7.18	2.68
M1125036.00	180	1/17	30:1	56	60	8.74	7.18	2.68
M1125037.00	180	1/17	60:1	100	30	8.74	7.18	2.68
M1125046.00	180	1/40	450:1	40	4	9.30	7.74	3.24
M1125047.00	180	1/20	180:1	100	10	9.30	7.74	3.24
M1125048.00	180	1/20	90:1	100	20	9.30	7.74	3.24

				TOLERANCES UNLESS SPECIFIED		LEESON	ELECTRIC MOTORS GEARMOTORS AND DRIVES	DRAWN RWS 3/7/05			
				DEC.	INCHES			CHK	RPB	3/8/05	
				.X	±.1	TITLE		APPD			
				.XX	±.03	OUTLINE		SCALE 1=2			
				.XXX	±.005	30 FRAME DC-PZ GEARBOX		REF M1115000-1125048			
00	RELEASED COMM CONVERSION PROJECT	RWS	4/13/05	RPB	.XXXX	MAT'L		FMF M1115002.00			
NO.	REVISION	BY & DATE	CHK	ANG	±1/2"	FINISH		PREV			
THIS DRAWING IN DESIGN AND DETAIL IS OUR PROPERTY AND MUST NOT BE USED EXCEPT IN CONNECTION WITH OUR WORK ALL RIGHTS OF DESIGN AND INVENTION ARE RESERVED THIS IS AN ELECTRONICALLY GENERATED DOCUMENT - DO NOT SCALE THIS PRINT						RFP	CAD FILE	M1030957	SIZE	DRAWING NO.	REV.
						DIST			B	M1030957.00	00

D.C. MOTORS

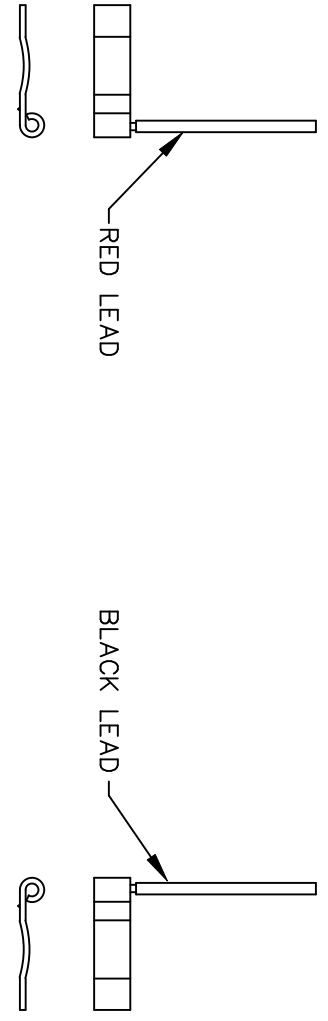
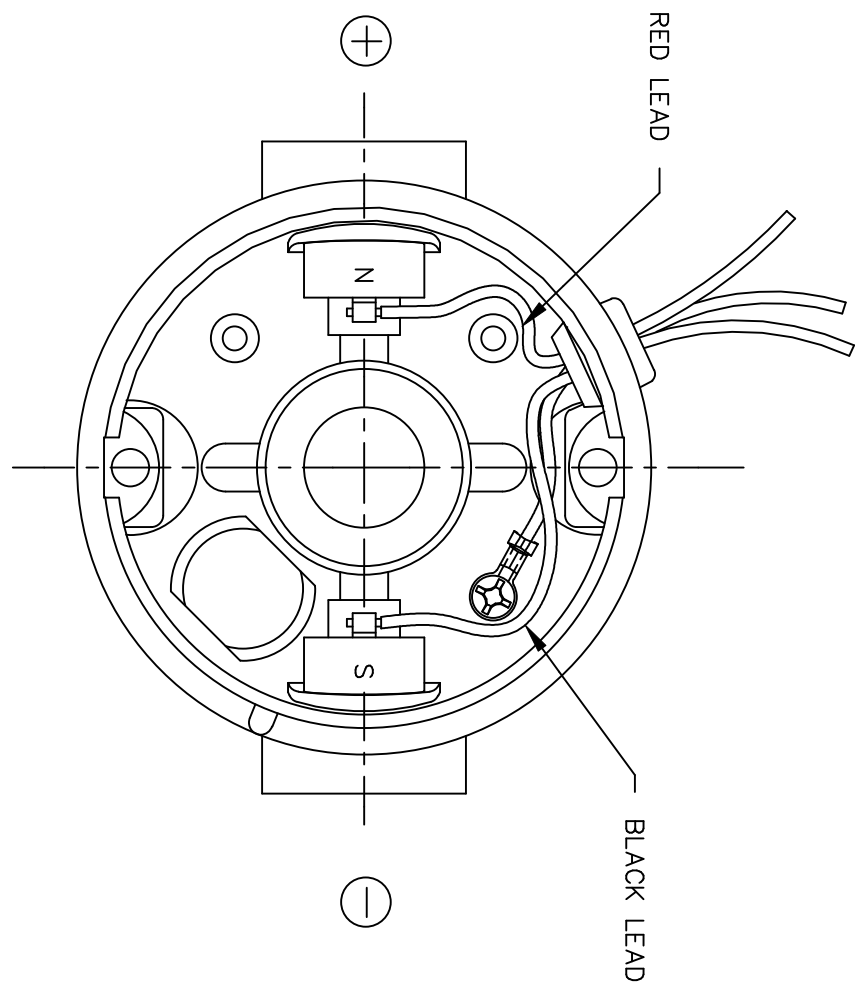

EXTERNAL CONNECTIONS FOR CW ROTATION
 VIEWING LEAD END OF MOTOR WITH RED LEAD
 POSITIVE (+) AND BLACK LEAD NEGATIVE (-)
 FOR CCW ROTATION REVERSE POLARITY

				TOLERANCES UNLESS SPECIFIED		 ELECTRIC MOTORS GEARMOTORS AND DRIVES	DRAWN RWS 3/15/05 CHK RPB 3/15/05 APPD SCALE 1=1 REF 901.706 FMF PREV
				DEC.	INCHES		TITLE CONNECTION DIAGRAM MAT'L. FINISH
				.X	±.1		
				.XX	±.01		
				.XXX	±.005		
00	RELEASED COMM CONVERSION PROJECT	RWS 4/13/05	RPB	.XXXX	±.0005	CAD FILE M100530201	SIZE A DRAWING NO. M1005302.01 REV. 00
NO.	REVISION	BY & DATE	CHK	ANG	±1/2"	DIST	

THIS DRAWING IN DESIGN AND DETAIL IS OUR PROPERTY AND MUST NOT BE USED EXCEPT IN CONNECTION WITH OUR WORK ALL RIGHTS OF DESIGN AND INVENTION ARE RESERVED THIS IS AN ELECTRONICALLY GENERATED DOCUMENT - DO NOT SCALE THIS PRINT