

Model: PFWRC2017C1F

Features:

Power-Flo circulator pumps are low noise, low leakage, reliable operation and easy installation. Single and three speed compact, efficient wet rotor circulators for closed loop (cast iron volute) hydronic heating and cooling circulation and open loop (bronze and stainless steel) domestic water recirculation applications. FOR INDOOR USE ONLY.

- **MOTOR:** 2-pole, 3600rpm, single phase, PSC with Thermal protection
- **LIQUID TEMPERATURE:** 32°F - 230°F
- **MAX. SYSTEM PRESSURE:** 145 PSI
- **INSULATION:** Class H
- **VOLUTE:** Cast Iron
- **CONNECTION:** GF 15 Flange with two 1/2" Dia. Holes
- **WARRANTY:** 3 year



Wet Rotor Circulator Pumps Three Speed Closed System type

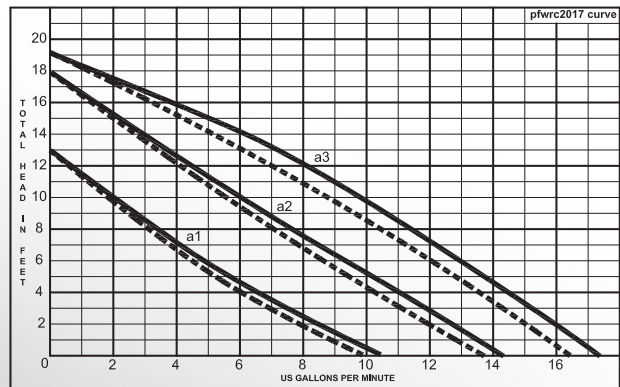
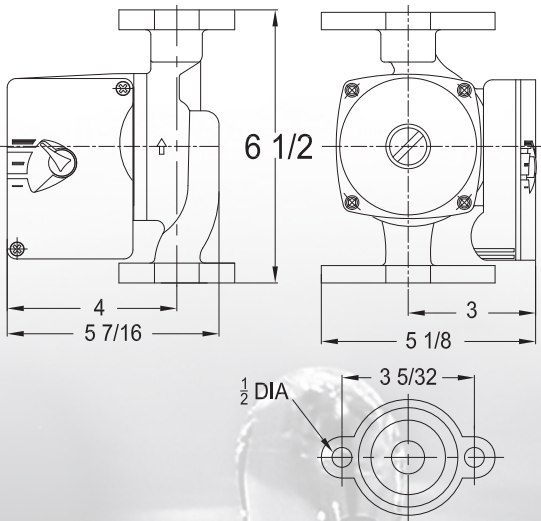

"—" without check valve, "----" with check valve

MODEL/PART NUMBER	VOLTS/PHASE	AMPS	WATTS	CURVE	CAPACITOR	WT. lbs
PFWRC2017C1F	115/1	0.9/0.7/0.5	100/70/55	a3 / a2 / a1	10mfd/250V	7.25

PF	WRC	21	20	Volute Material C, B, S	Motor Voltage 1 or 2	Connection Type F, S, U
Power-Flo	Wet Rotor Circulator	Shut Off Head (ft)	Max Flow (Gal)	C = Cast Iron B = Lead Free Bronze S = Stainless Steel	1 = 115 V 2 = 230V/1P	F = Flanged S = Copper Sweat U = Union

EXAMPLE: PFWRC2120C1F - Power-Flo Pumps - Wet Rotor Circulator - 21' Shut Off Head - 20 GPM Max Flow - Cast Iron Volute - 115 Volt, Flanged Connection.