

# Operating Instructions

## Series L NM400 Cord Reels

Model Numbers:

L NM450 163 X	L NM450 123 X
L NM450 143 X	L NM440 124 X
L NM445 144 X	L NM440 103 X
L NM425 123 X	L NM430 104 X



### IMPORTANT SAFETY INSTRUCTIONS

Please read this manual carefully and follow its instructions. Improper use or failure to follow these instructions could result in serious injury, death or property damage. Operators should be instructed in the safe and proper use and maintenance of this product. Keep this manual for future reference.

The following safety precautions call attention to potentially dangerous conditions.

**⚠ DANGER:** Immediate hazards which **WILL** result in severe personal injury or death.

**⚠ WARNING:** Hazards or unsafe practices which **COULD** result in severe personal injury or death.

**⚠ CAUTION:** Hazards or unsafe practices which **MAY** result in minor personal injury or product or property damage.

### INSTALLATION

**⚠ WARNING:** Lock out all electrical power and remove all spring tension from the reel before opening any enclosure or performing any service to this reel. Make sure all circuits carry appropriate fuse protection. Hazards or unsafe practices **COULD** result in severe personal injury or death.

**⚠ WARNING:** Failure to read, understand, and follow these instructions creates hazards that **COULD** result in personal injury or death.

**⚠ CAUTION:** Instruct operators in the safe, proper use, and maintenance of the reel. Keep this manual for future reference. Hazards or unsafe practices **MAY** result in minor personal injury or product or property damage.

### MOUNTING

The fixed base of the reel allows mounting in several different positions including base up, base down, or wall mounted. Here are general mounting requirements:

- Main-shaft must be horizontal.
- Centerline of the spool assembly must be in line with the cable run.
- When mounted overhead in base up position, add a secondary chain, bracket or other safety device to prevent reel from falling in case the mounting bolts are removed or become loosened by vibration.

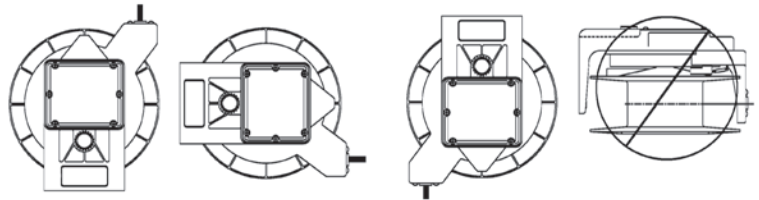

**⚠ DANGER:** A secondary safety cable or chain is to be attached to all reels mounted overhead to prevent reel from falling. Immediate hazards **WILL** result in severe personal injury or death.

Form# 1304-318 Rev: 3/2018

All reels mounted over head should have a secondary support chain to protect personnel in case of structure or mounting component failure. Attach one end of secondary support chain or cable to secondary support point on reel. Attach other end of secondary support chain or cable to a support component other than that which supports the reel. The chain or cable should be as short as possible allowing reel to drop no more than 6 to 12 inches if the primary connection is released. A secondary support is offered as an accessory item.

**PIVOT BASE**

If optional pivot base is used, four roller cable guide reel will align reel to direction of cable pull.

**WIRING**

**NOTE: The green wire has been grounded to the frame of the reel and spool, and cannot be used as a power conductor.**

A convenient one inch pipe thread opening has been provided at the bottom of the enclosure in base for connecting standard water tight cable connectors or conduit fitting--fittings not supplied. Individual power connections are made to the collector ring bus wires inside the junction box enclosure in base using commercially available twist on wire connectors or compression splices.

amp			220 v		
1 Phase			3 Phase		
Wire	Color	Number	Wire	Color	Number
L1	black	1	L1	black	1
N	white	2	L2	white	2
L3	red	3	L3	red	3
G	green	4	G	green	4

**WIRING SUPPLY CONNECTION**

**NOTE: See “Service, Working Cable Replacement/Installation” if cable needs to be installed.**

**ROLLER GUIDE AND SHEAVES**

Cable must exit guide in-line with pulling direction. If not, rotate guide arm as needed. The cable guide position is set by rotating spring pocket assembly. Loosen the three clamps holding spring pocket assembly in place by unscrewing the three hex head bolts. Unless required, do not completely remove bolts or clamps. Reposition guide as required, making sure clamps straddle ribs on outside diameter of spring pocket assembly and retighten hex head bolts.

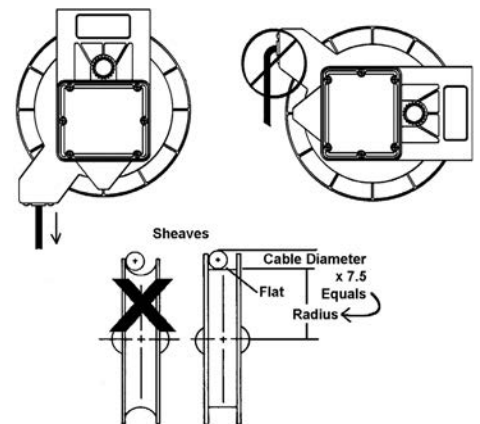

Sheaves are used to bend cable around corners. Typical minimum bend radius of the sheave should be about 7.5 x cable diameter. Requirements can vary depending on cable manufacturer specifications. Sheaves should have flat surfaces for cable to ride on. The movement of cable through a sheave should be in the same plane as the cable spool. Changing planes can greatly reduce cable life.

**CABLE WINDING**

There are many types of cable that may be installed on your cable reel depending on application. Select the cable most appropriate for your application requirements. Many cables come from the factory with a wax-like film that can encourage uneven wrapping. At initial set up it is common to use a dry lubricant (talc powder), or silicone based grease to encourage more even winding. Also critical to proper winding is the adequate setting of “Spring Tension”. See appropriate section. In some cases sheaves and unanticipated application features can require more tension than offered with standard reels. Contact factory for application assistance.

## OPERATION

### RATCHET LOCK

All models are supplied with a ratchet lock that works in any position. If ratchet lock is not required--constant tension--, move spring clip and spring to adjacent cable guide screw.



### SPRING TENSION

**CAUTION:** Do not connect working end of cable until the reel is properly pretensioned. Hazards or unsafe practices MAY result in minor personal injury or product or property damage.

**CAUTION:** Failure to test for adequate spring revolutions can cause spring damage. Hazards or unsafe practices MAY result in minor personal injury or product or property damage.

**NOTE:** A minimum of 2 pre-tension turns is required. Additional turns can be added as long as one unused spring turn remains when cable is fully extended. If entire cable cannot be pulled out, decrease spring tension until a full one turn remains.

All reels require pre-tensioning turns to spool assembly before connecting free end of working cable. Set spring tension by turning fully wrapped reel through a specific number of revolutions or turns.

Number of pre-tension turns depends on application and desired tension. **A minimum of 2 set up turns is needed for most applications. Additional tension may be added by repeating above process.** After tension is set, connect cable free end. Failure to pre-tension reel may result in insufficient tension to retract and may shorten spring life.

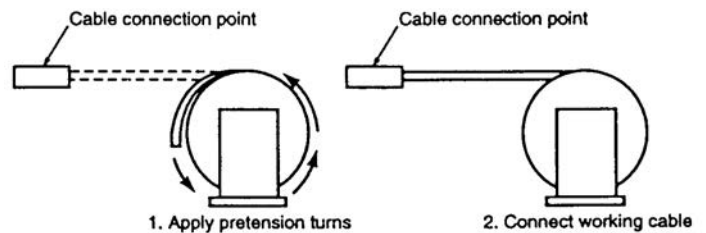

## SERVICE

### MAIN SPRING

**WARNING:** Always disconnect electrical power before dismantling any part of the reel. Fuse size must not be greater than maximum amperage capacity of cable. Remove all spring tension before attempting any service. Hazards or unsafe practices COULD result in severe personal injury or death.

**WARNING:** To prevent personal injury, death or property damage, handle all springs with care. Use suitable protective gloves for spring handling. Hazards or unsafe practices COULD result in severe personal injury or death.

**WARNING:** To prevent personal injury, death or property damage, hold center of spring down as the hub is pulled out. If the center is allowed to rise up, the spring may escape from its container. Hazards or unsafe practices COULD result in severe personal injury or death.

If reel will not develop tension or retract cable, spring assembly may need to be replaced. Remove junction box cover. Disconnect line-input wires from collector ring bus wires. Also disconnect cable free end and allow spring to unwind completely. Remove screw, shaft retainer, then pull complete spool assembly with cable from base. Remove cable guide, spring clip, ratchet spring, shoulder bolt and ratchet pawl from spring pocket assembly. Remove spring pocket assembly from base and replace with new part. To reassemble, reverse the above procedure making sure the dimple in the shaft retainer is toward the main shaft. Re-tension cable reel as per instructions.

## COLLECTOR RING REPLACEMENT

**⚠ WARNING:** Disconnect and lock out all power to reel and remove all tension on spring before servicing collector ring assembly. Hazards or unsafe practices **COULD** result in severe personal injury or death.

**⚠ CAUTION:** Check continuity and replace all covers before turning on electrical power. Hazards or unsafe practices **MAY** result in minor personal injury or product or property damage.

**⚠ WARNING:** Check placement of brush holder assemblies to make sure terminal locations are centered between the protruding lobes on the inner and outer drums. Hazards or unsafe practices **COULD** result in severe personal injury or death.

**NOTE:** Check position of cable entry in relationship to studs marked by “X” in figure. Replace subsequent brush assemblies in clockwise rotation.

To service the collector ring assembly, remove junction box cover and disconnect bus wires in junction box. Remove cover, if required, and outer drum-half. Unclip brush assembly from brush studs and remove. Notice position of brush assembly. Remove all brush assemblies from collector ring. Loosen collector ring set screw and slide collector ring off main shaft. To reassemble, reverse above procedure. The last brush assembly--one closest to steel hub on collector ring--must be assembled on brush studs indicated by the “X” in the figure to the right.

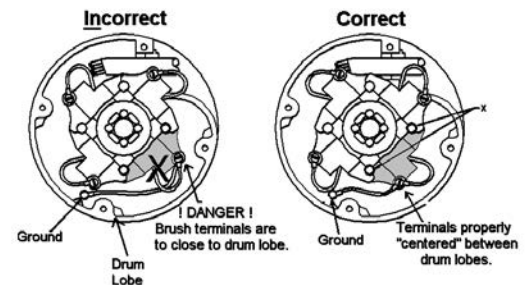

## WORKING CABLE REPLACEMENT/INSTALLATION

**⚠ WARNING:** Disconnect and lock out all power to reel and remove all tension on spring before servicing collector ring assembly. Hazards or unsafe practices **COULD** result in severe personal injury or death.

**⚠ CAUTION:** Check continuity and replace all covers before turning on electrical power. Hazards or unsafe practices **MAY** result in minor personal injury or product or property damage.

**NOTE:** Cable seal is a bellows type seal designed to fit different size cables. Pull out the bellows in one direction and cut the seal so that the through opening is at least 1/8" diameter smaller than the working cable. Always cut the seal smaller than required. More of the seal may be cut off if necessary.

This procedure applies to both new installations and for replacement of working cable. To install/replace cable loosen seal cover and cable seal. Remove cover, if required, and outer drum half. Loosen or remove cable clamp and individual conductors of working cable from brush assemblies. Pull working cable through opening of inner drum and remove seal cover, and cable seal from old working cable. Place seal cover and cable seal over replacement cable. To reassemble, reverse the above procedure. Be sure to connect working cable conductors to the proper brush assembly. Re-tension spring.

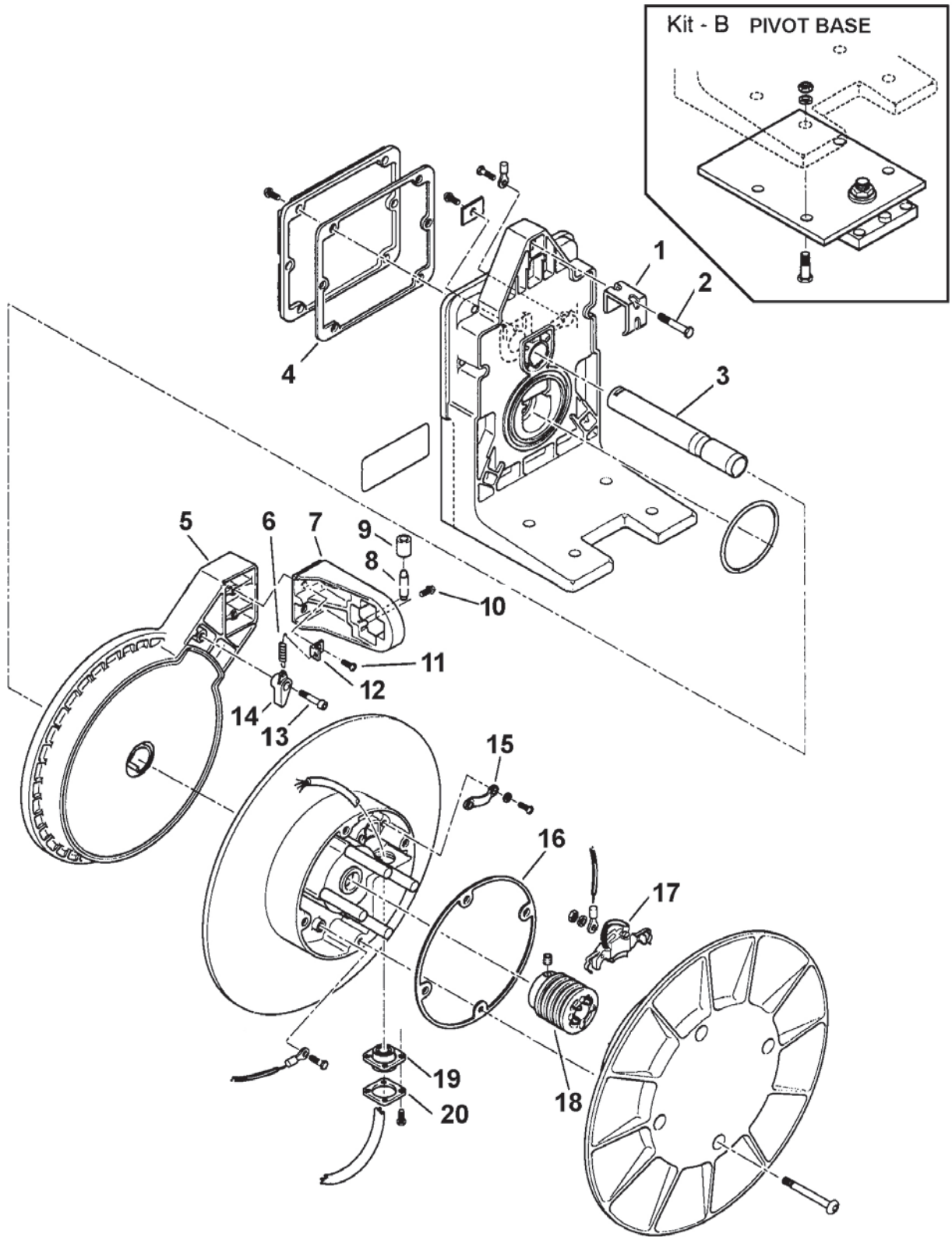

Series L NM400 Cord Reels

Item #	Description	# Req.	L NM450 143 X	L NM445 144 X	L NM425 123 X	L NM450 163 X
1	Clamp	3	Kit A	Kit A	Kit A	Kit A
2	Bolt hex head M6	3	Kit A	Kit A	Kit A	Kit A
3	Main shaft	1	263095	263095	263095	263095
4	Junction box gasket	1	263096	263096	263096	263096
5	Spring case assembly	1	263097	263097	263097	263098
6	Extension spring	1	263100	263100	263100	263100
7	Cable guide frame	1	Kit C	Kit C	Kit C	Kit C
8	Roller shaft	4	Kit C	Kit C	Kit C	Kit C
9	Roller	4	Kit C	Kit C	Kit C	Kit C
10	Screw pan head M6x16mm	4	Kit C	Kit C	Kit C	Kit C
11	Screw pan head M6x20mm	2	Kit C	Kit C	Kit C	Kit C
12	Spring clip	1	263101	263101	263101	263101
13	Screw shoulder M8x10x16	1	263102	263102	263102	263102
14	Ratchet pawl	1	263103	263103	263103	263103
15	Cable clamp	1	263104	263104	263104	263104
16	Drum gasket	1	263105	263105	263105	263105
17	Copper brush assembly - quantity one per # of conductors	3 or 4	263106	263106	263106	263106
18	Collector ring subassembly	1	263107	263108	263107	263107
19	Cable seal	1	263112	263112	263112	263112
20	Seal cover	1	263113	263113	263113	263113
Kit A	Clamp kit - 3 sets, stainless steel	1	263110	263110	263110	263110
Kit B	Pivot base - optional	1	263109	263109	263109	263109
Kit C	Roller guide kit	1	263111	263111	263111	263111

Item #	Description	# Req.	L NM450 123 X	L NM440 124 X	L NM440 103 X	L NM430 104 X
1	Clamp	3	Kit A	Kit A	Kit A	Kit A
2	Bolt hex head M6	3	Kit A	Kit A	Kit A	Kit A
3	Main shaft	1	263095	263095	263095	263095
4	Junction box gasket	1	263096	263096	263096	263096
5	Spring case assembly	1	263099	263099	263099	263099
6	Extension spring	1	263100	263100	263100	263100
7	Cable guide frame	1	Kit C	Kit C	Kit C	Kit C
8	Roller shaft	4	Kit C	Kit C	Kit C	Kit C
9	Roller	4	Kit C	Kit C	Kit C	Kit C
10	Screw pan head M6x16mm	4	Kit C	Kit C	Kit C	Kit C
11	Screw pan head M6x20mm	2	Kit C	Kit C	Kit C	Kit C
12	Spring clip	1	263101	263101	263101	263101
13	Screw shoulder M8x10x16	1	263102	263102	263102	263102
14	Ratchet pawl	1	263103	263103	263103	263103
15	Cable clamp	1	263104	263104	263104	263104
16	Drum gasket	1	263105	263105	263105	263105
17	Copper brush assembly - quantity one per # of conductors	3 or 4	263106	263106	263106	263106
18	Collector ring subassembly	1	263107	263108	263107	263108
19	Cable seal	1	263112	263112	263112	263112
20	Seal cover	1	263113	263113	263113	263113
Kit A	Clamp kit - 3 sets, stainless steel	1	263110	263110	263110	263110
Kit B	Pivot base - optional	1	263109	263109	263109	263109
Kit C	Roller guide kit	1	263111	263111	263111	263111